



**U.S. Army Corps  
of Engineers**

**Galveston District  
Southwestern Division**

---

# **Houston Ship Channel Expansion Channel Improvement Project, Harris, Chambers, and Galveston Counties, Texas**

## **Engineering Appendix C**



November 2019

*(This page left blank intentionally.)*



**DEPARTMENT OF THE ARMY  
GALVESTON DISTRICT, CORPS OF ENGINEERS  
P. O. BOX 1229  
GALVESTON, TEXAS 77553-1229**

**Houston Ship Channel Expansion Channel Improvement Project,  
Harris, Chambers, and Galveston Counties, Texas**

**Engineering Appendix C**

**November 2019**

*(This page left blank intentionally.)*



## **EXECUTIVE SUMMARY**

---

### **Study Description**

The purpose of this Feasibility Study is to evaluate Federal interest in alternative plans (including the No-Action Plan) for reducing transportation costs and addressing navigation safety issues on the Houston Ship Channel (HSC) system and assess the effects of the alternatives on the natural system and human environment, including the economic development of existing inefficiencies. The scope includes six segments of the HSC, which will be evaluated for current and projected vessel size and traffic. Beginning at the most seaward end of the HSC along Bolivar Roads at the Galveston Entrance Channel, the study examined possible moorings and bay widening to provide for safe meeting opportunities in the Bay Reach, as well as study the tributary channels at Bayport Ship Channel (BSC), and Barbours Cut Channel (BCC). Additionally, the study evaluated at the upper reach of the HSC between Boggy Bayou and the Main Turning Basin for deepening opportunities and widening where practicable. Dredged material placement is evaluated for upland confined placement, beneficial Use (BU) of dredged material, where practicable, and offshore placement at Ocean Dredged Material Disposal Sites (ODMDS). Figure 1-1 provides an overview of the study segments in the study scope.

*(This page left blank intentionally.)*

# TABLE OF CONTENTS

---

|  | <b>Page</b> |
|--|-------------|
| <b>EXECUTIVE SUMMARY.....</b>  | <b>ES-1</b> |
| <b>1 GENERAL.....</b>  | <b>1-1</b>  |
| 1.1 INTRODUCTION .....   | 1-1         |
| 1.1.1 Segment 1: Bay Reach.....                                      | 1-2         |
| 1.1.2 Segment 2: Bayport Ship Channel .....                          | 1-3         |
| 1.1.3 Segment 3: Barbours Cut Channel .....                          | 1-3         |
| 1.1.4 Segment 4: Boggy Bayou to Sims Bayou .....                     | 1-3         |
| 1.1.5 Segment 5: Sims Bayou to I-610 Bridge.....                     | 1-4         |
| 1.1.6 Segment 6: I-610 Bridge to Turning Basin .....                 | 1-4         |
| 1.2 PHYSICAL DESCRIPTION OF THE EXISTING PROJECT.....                | 1-4         |
| 1.3 CURRENT CHANNEL RESTRICTIONS.....                                | 1-5         |
| <b>2 EXISTING CONDITIONS.....</b>                                    | <b>2-1</b>  |
| 2.1 SURVEYING, MAPPING, AND OTHER GEOSPATIAL DATA REQUIREMENTS ..... | 2-1         |
| 2.1.1 Surveys .....  | 2-1         |
| 2.1.2 Mapping.....   | 2-1         |
| 2.1.3 Datum .....  | 2-1         |
| 2.2 TIDES, CURRENTS, WIND, WAVES, AND WATER LEVEL.....               | 2-2         |
| 2.3 RELATIVE SEA LEVEL CHANGE .....                                  | 2-3         |
| <b>3 CHANNEL DESIGN CONSIDERATIONS.....</b>                          | <b>3-1</b>  |
| 3.1 DESIGN VESSELS.....  | 3-1         |
| 3.2 CHANNEL MODIFICATIONS.....                                       | 3-2         |
| 3.2.1 Bend Easings .....   | 3-2         |
| 3.2.2 Channel Widening.....  | 3-2         |
| 3.2.3 Turning Basins.....  | 3-3         |
| 3.3 CHANNEL SLOPE STABILITY ANALYSIS.....                            | 3-4         |
| <b>4 MEASURES EVALUATED.....</b>                                     | <b>4-1</b>  |
| 4.1 BEND EASINGS.....  | 4-3         |
| 4.1.1 Segment 1 .....  | 4-4         |
| 4.1.2 Segment 2 .....  | 4-5         |
| 4.1.3 Segment 3 .....  | 4-6         |
| 4.2 CHANNEL WIDENING .....   | 4-7         |
| 4.2.1 Segment 1 .....  | 4-8         |
| 4.2.2 Segment 2 .....  | 4-10        |
| 4.2.3 Segment 3 .....  | 4-12        |
| 4.2.4 Segment 4 .....  | 4-15        |
| 4.3 CHANNEL DEEPENING .....  | 4-16        |
| 4.3.1 Segment 4 .....  | 4-16        |
| 4.3.2 Segment 5 .....  | 4-17        |
| 4.3.3 Segment 6 .....  | 4-17        |
| 4.4 TURNING BASINS .....   | 4-17        |
| 4.4.1 Segment 3 .....  | 4-17        |

|          | Page   |
|----------|--|
| 4.4.2    | Segment 4..... 4-18  |
| 4.4.3    | Segment 6..... 4-18  |
| 4.4.4    | BSC Flare Sedimentation Attenuation Feature ..... 4-18                                   |
| 4.5      | SHEET PILING..... 4-21   |
| 4.6      | AIDS TO NAVIGATION..... 4-22   |
| 4.7      | TYPICAL DREDGE MATERIAL USE OPTIONS ..... 4-23   |
| 4.7.1    | Beneficial Use ..... 4-23  |
| 4.7.2    | Upland Confined Placement Areas ..... 4-33   |
| <b>5</b> | <b>QUANTITY COMPUTATIONS..... 5-1</b>  |
| 5.1      | NEW WORK QUANTITIES ..... 5-1  |
| 5.1.1    | Segment 1: Bay Reach..... 5-2  |
| 5.1.2    | Segment 2: Bayport Ship Channel ..... 5-3  |
| 5.1.3    | Segment 3: Barbours Cut Channel ..... 5-4  |
| 5.1.4    | Segment 4: Boggy Bayou to Sims Bayou ..... 5-5   |
| 5.1.5    | Segment 5: Sims Bayou to I-610 Bridge..... 5-5   |
| 5.1.6    | Segment 6: I-610 Bridge to Turning Basin ..... 5-6                                       |
| 5.2      | SHOALING RATES ..... 5-6   |
| 5.2.1    | Existing Shoaling Rates..... 5-6   |
| 5.2.2    | Estimated Shoaling Rates..... 5-7  |
| 5.2.3    | Shoaling Estimate from the Numerical Model..... 5-9                                      |
| 5.2.4    | Sediment Model Calibration to Corps Shoaling Analysis Tool<br>(CSAT) Estimates..... 5-13 |
| 5.2.5    | Local Service Facilities ..... 5-17  |
| 5.2.6    | Channel Improvements Potential Effects on Existing and Planned<br>Structures..... 5-20   |
| <b>6</b> | <b>GEOTECHNICAL ..... 6-1</b>  |
| 6.1      | EXISTING BORINGS..... 6-1  |
| 6.1.1    | Segment 1: Bay Reach..... 6-1  |
| 6.1.2    | Segment 2: Bayport Ship Channel ..... 6-2  |
| 6.1.3    | Segment 3: Barbours Cut Channel ..... 6-2  |
| 6.1.4    | Segment 4: Boggy Bayou to Sims Bayou ..... 6-2   |
| 6.1.5    | Segment 5: Sims Bayou to I-610 Bridge..... 6-2   |
| 6.1.6    | Segment 6: I-610 Bridge to Turning Basin ..... 6-2                                       |
| 6.2      | FUTURE INVESTIGATIONS/RECOMMENDATION ..... 6-3   |
| 6.2.1    | Segment 1: Bay Reach..... 6-3  |
| 6.2.2    | Segment 2: Bayport Ship Channel ..... 6-5  |
| 6.2.3    | Segment 3: Barbours Cut Channel ..... 6-5  |
| 6.2.4    | Segment 4: Boggy Bayou to Sims Bayou ..... 6-6   |
| 6.2.5    | Segment 5: Sims Bayou to I-610 Bridge..... 6-7   |
| 6.2.6    | Segment 6: I-610 Bridge to Turning Basin ..... 6-7                                       |
| 6.3      | NEW WORK MATERIALS ..... 6-7   |
| 6.4      | MAINTENANCE MATERIALS ..... 6-17   |
| <b>7</b> | <b>ENVIRONMENTAL CONSIDERATIONS ..... 7-1</b>  |

|   | Page        |
|---|-------------|
| 7.1 ENVIRONMENTAL ENGINEERING.....  | 7-1         |
| 7.1.1 Design of Positive Environmental Attributes into the Project .....  | 7-1         |
| 7.1.2 Inclusion Of Environmentally Beneficial Operations And<br>Management For The Project .....  | 7-1         |
| 7.1.3 Maintenance Of Ecological Continuity In The Project With The<br>Surrounding Area And Within The Region.....                           | 7-1         |
| 7.1.4 Consideration of Indirect Environmental Costs and Benefits .....  | 7-1         |
| 7.1.5 Integration of Environmental Sensitivity Into All Aspects Of The<br>Project.....  | 7-1         |
| 7.1.6 Perusal Of The Environmental Review Guide For Operations With<br>Respect To Environmental Problems At Similar Existing Projects. .... | 7-2         |
| 7.1.7 Incorporation if Environmental Compliance Measures Into The<br>Project Design .....   | 7-2         |
| 7.2 MITIGATION.....   | 7-2         |
| 7.3 CALCULATING IMPACTS TO MAPPED OYSTER REEFS.....   | 7-2         |
| 7.4 WETLANDS.....   | 7-4         |
| 7.5 HAZARDOUS AND TOXIC MATERIALS .....   | 7-4         |
| 7.6 SALINITY MODELING WITH ADH.....   | 7-5         |
| 7.6.1 Model Results.....  | 7-5         |
| 7.6.2 Salinity Slice Analysis.....  | 7-6         |
| 7.7 DISSOLVED OXYGEN .....  | 7-7         |
| <b>8 REAL ESTATE .....</b>  | <b>8-1</b>  |
| <b>9 UTILITIES AND FACILITIES .....</b>   | <b>9-1</b>  |
| <b>10 COSTS .....</b>   | <b>10-1</b> |
| 10.1 INTRODUCTION .....   | 10-1        |
| 10.1.1 General .....  | 10-1        |
| 10.1.2 Equipment & Labor.....   | 10-1        |
| 10.2 PROJECT FIRST COSTS .....  | 10-1        |
| 10.2.1 General .....  | 10-1        |
| 10.2.2 NW Materials to be Dredged.....  | 10-2        |
| 10.2.3 NW Placement Options .....   | 10-3        |
| 10.2.4 NW Production Variables.....   | 10-6        |
| 10.2.5 NW Cost Considerations .....   | 10-7        |
| 10.2.6 Pipeline Relocations .....   | 10-11       |
| 10.2.7 Associated Costs.....  | 10-11       |
| 10.3 50-YEAR O&M COSTS .....  | 10-14       |
| 10.3.1 General .....  | 10-14       |
| 10.3.2 O&M Materials to be Dredged.....   | 10-14       |
| 10.3.3 O&M Placement Options .....  | 10-17       |
| 10.3.4 O&M Production Variables.....  | 10-18       |
| 10.3.5 O&M Cost Considerations .....  | 10-23       |
| 10.4 LSF MAINTENANCE .....  | 10-25       |
| <b>11 RECOMMENDED PLAN .....</b>  | <b>11-1</b> |

|           | Page   |             |
|-----------|--|-------------|
| <b>12</b> | <b>ADDITIONAL STUDIES</b> .....                        | <b>12-1</b> |
|           | 12.1 HYDRODYNAMIC MODELING.....                        | 12-1        |
|           | 12.1.1 Model Setup.....                                | 12-2        |
|           | 12.1.2 Planned Simulations.....                        | 12-2        |
|           | 12.2 SHIP SIMULATION.....                              | 12-3        |
|           | 12.3 ADVANCED MAINTENANCE AND ALLOWABLE OVERDEPTH..... | 12-4        |
| <b>13</b> | <b>SCHEDULE OF DESIGN AND CONSTRUCTION</b> .....       | <b>13-1</b> |
| <b>14</b> | <b>OPERATION AND MAINTENANCE</b> .....                 | <b>14-1</b> |
| <b>15</b> | <b>ACCESS ROADS</b> .....                              | <b>15-1</b> |
| <b>16</b> | <b>PROJECT SECURITY</b> .....                          | <b>16-1</b> |
| <b>17</b> | <b>REFERENCES</b> .....                                | <b>17-1</b> |

## FIGURES

|   | Page |
|---|------|
| Figure 1-1: Six Study Segments of the HSC ECIP Feasibility Study.....   | 1-1  |
| Figure 1-2: Location of Markers Referenced in HP Working Rules.....   | 1-8  |
| Figure 2-1: BSC and BCC vertical datum relationship for converting survey data.....   | 2-2  |
| Figure 3-1: New work and O&M Dredging Templates Modified for SWG Policy.....  | 3-4  |
| Figure 4-1: Segment 1 Bay Reach Bend Easing Measures for the Existing 530-foot channel.....   | 4-4  |
| Figure 4-2: BSC Flare Easing 5,375 feet (BE2_BSCFlare).....   | 4-5  |
| Figure 4-3: BETB3_BCCFlare_1800NS – BCC Flare Easing and 1,800-Foot Turning Basin.....  | 4-7  |
| Figure 4-4: Channel Types Defined in EM 110-2-1613.....   | 4-7  |
| Figure 4-5: Bay Reach Widening 700 Feet from Bolivar Roads to BCC Cross Section.....  | 4-9  |
| Figure 4-6: Transition at Station 78+844 from CW1_BR-Redfish_700 to existing 530-foot channel.....  | 4-9  |
| Figure 4-7: CW2_BSC_455 - BSC Widening 455 Feet.....  | 4-12 |
| Figure 4-8: CW3_BCC_455 - BCC Widening 455 Feet.....  | 4-14 |
| Figure 4-9: CW4_BB-GB_530 – Boggy Bayou to Greens Bayou Widening 530 Feet.....  | 4-16 |
| Figure 4-10: TB4_Hunting - Segment 4 Turning Basin at Hunting Bayou.....  | 4-18 |
| Figure 4-11: TB6_Brady – Segment 6 Brady Island Turning Basin.....  | 4-18 |
| Figure 4-12: BSC Flare Sedimentation Attenuation Feature.....   | 4-20 |
| Figure 4-13: Typical Sheet Pile Section.....  | 4-22 |
| Figure 4-14: 8-Acre Bird Island Plan View.....  | 4-25 |
| Figure 4-15: 8-Acre Bird Island Cross Section.....  | 4-25 |
| Figure 4-16: Long Bird Island Plan View.....  | 4-26 |
| Figure 4-17: Long Bird Island Cross Section.....  | 4-26 |
| Figure 4-18: Oyster Catcher nesting one day after completion of the Dickinson Bay Island Ground Nesting Habitat Enhancement Project (Source: Galveston Bay Foundation)..... | 4-26 |
| Figure 4-19: Bird Island Marsh Cross Section.....   | 4-27 |

|   | Page |
|---|------|
| Figure 4-20: Bird Island Marsh Plan View.....   | 4-27 |
| Figure 4-21: BU sites M11 & M12.....  | 4-28 |
| Figure 4-22: Typical perimeter dike cross section for M11 & M12.....  | 4-29 |
| Figure 4-23: Conceptual layout of BABUS cells .....   | 4-30 |
| Figure 4-24: Bay Aquatic Beneficial Use Site.....   | 4-32 |
| Figure 4-25: Typical Section of Hydraulic Fill at an Existing UCPA.....   | 4-33 |
| Figure 4-26: Mid Bay UCPAs .....  | 4-34 |
| Figure 4-27: New Bayou Upland Confined Placement Areas .....  | 4-36 |
| Figure 4-28: Typical Bayou UCPA Initial Dike Section .....  | 4-36 |
| Figure 5-1: 700-FT Channel Widening Typical Template .....  | 5-2  |
| Figure 5-2: HSC dredge template for shoaling analysis .....   | 5-10 |
| Figure 5-3: Shoaling results by reach for alternatives .....  | 5-11 |
| Figure 5-4: Modeled bed displacement along HSC (non-scaled, focus on the change; *<br>Focus separately on changes between the present and future to isolate project impacts). ..... | 5-12 |
| Figure 5-5: Shoaling impacts under various alternative conditions (*Focus separately on<br>changes between the present and future to isolate project impacts) .....                 | 5-13 |
| Figure 5-6: AdH Model Scaled Shoaling Results.....  | 5-15 |
| Figure 5-7: ECIP Alternative Scaled AdH Model Shoaling Volume Results for Annual<br>Report reaches.....   | 5-16 |
| Figure 5-8: LSFs projected to benefit from the HSC ECIP .....   | 5-17 |
| Figure 5-9: Estimating LSF footprint .....  | 5-17 |
| Figure 6-1: Hand Probing .....  | 6-3  |
| Figure 6-2: Jet Probing.....  | 6-4  |
| Figure 6-3: Typical Probing Field Log .....   | 6-4  |
| Figure 6-4: Proposed borings for CW2_BSCFlare.....  | 6-5  |
| Figure 6-5: Proposed borings for BCC 1,800-foot Flare Easing and Turning Basin<br>(BETB3_BCCFlare_1800NS) .....   | 6-6  |
| Figure 6-6: Geotechnical Profile Segment 1 - Lower Bay .....  | 6-9  |
| Figure 6-7: Geotechnical Profile Segment 1 - Upper Bay.....   | 6-10 |
| Figure 6-8: Geotechnical Profile Segment 1 - Mid Bay .....  | 6-10 |
| Figure 6-9: Geotechnical Profile Segment 1 - Upper Bay.....   | 6-11 |
| Figure 6-10: Geotechnical Profile Segment 2.....  | 6-12 |
| Figure 6-11: Geotechnical Profile Segment 3.....  | 6-13 |
| Figure 6-12: Geotechnical Profile Segment 4, 5, & 6.....  | 6-14 |
| Figure 7-1: Potential Oyster Impact Limits .....  | 7-3  |
| Figure 7-2: HSC key feature refecnce map.....   | 7-6  |
| Figure 7-3: HSC slice analysis reference map.....   | 7-6  |
| Figure 7-4: HSC average sality slice results .....  | 7-7  |

## TABLES

|  | Page |
|--|------|
| Table 1-1: Channel Dimensions for HSC and Tributaries..... | 1-5  |

|   | Page  |
|---|-------|
| Table 2-1: Summary of Relative Sea Level Change Estimates (Levels are relative to 1992 Zero)..... | 2-5   |
| Table 3-1: Design Vessels per Study Segment.....  | 3-1   |
| Table 3-2: Recommended Channel Turn Configurations.....   | 3-2   |
| Table 3-3: One-Way Ship Traffic – Channel Width Design Criteria.....                              | 3-3   |
| Table 3-4: Two-Way Ship Traffic – Channel Width Design Criteria.....                              | 3-3   |
| Table 4-1: Measures Evaluated.....  | 4-2   |
| Table 4-2: Calculated Bend Easing Requirements by Vessel Type.....                                | 4-3   |
| Table 4-3: HSC Test Cases – Channel Width Design Criteria.....                                    | 4-8   |
| Table 4-4: BSC Design Widths by Vessel Size.....  | 4-11  |
| Table 4-5: BCC Design Widths by Vessel Size.....  | 4-13  |
| Table 4-6: ATONs for Relocation.....  | 4-23  |
| Table 4-7: Mid Bay UCPA Volumes.....  | 4-35  |
| Table 4-8: Bayou Confined UCPA Quantities.....  | 4-37  |
| Table 5-1: Survey Data used to Calculate Material Quantity.....                                   | 5-1   |
| Table 5-2: Currently Authorized Depths for Segment 1.....   | 5-3   |
| Table 5-3: New Work Quantities for Segment 1.....   | 5-3   |
| Table 5-4: New Work Quantities for Segment 2.....   | 5-4   |
| Table 5-5: New Work Quantities for Segment 3.....   | 5-4   |
| Table 5-6: Currently Authorized Depths for Segment 4.....   | 5-5   |
| Table 5-7: New Work Quantities for Segment 4.....   | 5-5   |
| Table 5-8: New Work Quantities for Segment 5.....   | 5-6   |
| Table 5-9: New Work Quantities for Segment 6.....   | 5-6   |
| Table 5-10: Existing Federal Shoaling Rates.....  | 5-7   |
| Table 5-11: Estimated Shoaling Rates.....   | 5-8   |
| Table 5-12: Estimated Shoaling Rates using Volume of Cut Method.....                              | 5-9   |
| Table 5-13: LSF New Work Quantities.....  | 5-18  |
| Table 5-14: LSF O&M Quantities.....   | 5-19  |
| Table 5-15: LSF Non-Federal Shoaling Summary (21 Benefiting Docks).....                           | 5-20  |
| Table 6-1: Categorization of materials based on their consistency or relative density.....        | 6-7   |
| Table 6-2: HSC-ECIP NW Material Classification.....   | 6-15  |
| Table 6-3: Maintenance Material Sediment Grain Size.....  | 6-17  |
| Table 7-1: Mitigation Requirements.....   | 7-3   |
| Table 7-2: HTRW Sites Near Project Vacinity.....  | 7-4   |
| Table 10-1: HSC-ECIP Study Channel Measures.....  | 10-2  |
| Table 10-2: Segment 1 – Bolivar to Redfish Materials (Reach Separation by Quality).....           | 10-3  |
| Table 10-3: Segment 1 – Redfish to BSC Materials (Reach Separation by Quality).....               | 10-3  |
| Table 10-4: NW Placement Options.....   | 10-4  |
| Table 10-5: New Work Dredging Pipeline Lengths.....   | 10-6  |
| Table 10-6: LSF Dredging Distances.....   | 10-11 |
| Table 10-7: LSF Cost Estimates.....   | 10-12 |
| Table 10-8: Cost for ATON Relocation.....   | 10-12 |
| Table 10-9: O&M Material Quantities.....  | 10-16 |
| Table 10-10: O&M Placement Options.....   | 10-17 |



|   | Page  |
|---|-------|
| Table 10-11: O&M Dredging Pipeline Lengths .....        | 10-18 |
| Table 10-12: O&M Production Rates .....                 | 10-22 |
| Table 10-13: BABUS Costs.....                           | 10-25 |
| Table 11-1: Recommended Plan Channel Measures .....     | 11-1  |
| Table 11-2: Placement Options for New Work and O&M..... | 11-2  |

## PLATES

| <u>No.</u> | <u>Title</u>  |
|------------|---|
| 01         | Study Area  |
| 02         | NED Plan Overview   |
| 03         | Recommended Plan LPP Overview   |
| 04         | NED Plan Segment 1a – Bolivar Roads to Redfish  |
| 05         | NED Plan Segment 1a – Bolivar Roads to Redfish  |
| 06         | NED Plan Segment 1a – Bolivar Roads to Redfish  |
| 07         | NED Plan Segment 1a – Bolivar Roads to Redfish  |
| 08         | NED Plan – Segment 2 – Bayport Ship Channel   |
| 09         | NED Plan – Segment 2 – Bayport Ship Channel   |
| 10         | NED Plan – Segment 3 – Barbours Cut Channel   |
| 11         | NED Plan – Segment 4 – Boggy Bayou to Sims Bayou  |
| 12         | NED Plan – Segment 4 – Boggy Bayou to Sims Bayou  |
| 13         | NED Plan – Segment 5 – Sims Bayou to I-610 Bridge   |
| 14         | NED Plan – Segment 6 – I-610 Bridge to Main TB  |
| 15         | Recommended Plan – LPP, Segment 1a – Bolivar Roads to Redfish                               |
| 16         | Recommended Plan – LPP, Segment 1a – Bolivar Roads to Redfish                               |
| 17         | Recommended Plan – LPP, Segment 1a – Bolivar Roads to Redfish                               |
| 18         | Recommended Plan – LPP, Segment 1a – Bolivar Roads to Redfish & Segment 1b – Redfish to BSC |
| 19         | Recommended Plan – LPP, Segment 1b – Redfish to BSC   |
| 20         | Recommended Plan – LPP, Segment 1b – Redfish to BSC   |
| 21         | Recommended Plan – LPP, Segment 1b – Redfish to BSC & Segment 1c – BSC to BCC               |
| 22         | Recommended Plan – LPP, Segment 1c- BSC to BCC  |
| 23         | Recommended Plan – LPP, Segment 1c- BSC to BCC  |
| 24         | Recommended Plan – LPP, Segment 2 – Bayport Ship Channel                                    |
| 25         | Recommended Plan – LPP, Segment 2 – Bayport Ship Channel                                    |
| 26         | Recommended Plan – LPP, Segment 3 – Barbours Cut Channel                                    |
| 27         | Recommended Plan – LPP, Segment 4 – Boggy Bayou to Sims Bayou                               |
| 28         | Recommended Plan – LPP, Segment 4 – Boggy Bayou to Sims Bayou                               |
| 29         | Recommended Plan – LPP, Segment 5 – Sims Bayou to I-610 Bridge                              |
| 30         | Recommended Plan – LPP, Segment 6 – I-610 Bridge to Main TB                                 |
| 31         | Segment 1, 2, & 3 Beneficial Use Sites  |
| 32         | Bird Island Marsh Beneficial Use Site   |
| 33         | 8-Acre Bird Island Beneficial Use Site  |
| 34         | Long Bird Island Beneficial Use Site  |
| 35         | Segment 4, 5, & 6 New Upland Confined Placement Areas                                       |
| 36         | Rosa Allen Expansion Placement Area   |
| 37         | East 2 Clinton Placement Area   |
| 38         | Beltway 8 Placement Area  |

## ATTACHMENTS

*Italicized reference documents are available upon request to the Galveston District Project Management*

|               |   |
|---------------|---|
| Attachment 1  | Engineering Plates<br>Cost Estimate (MII v4.2)/TPCS/CSRA  |
| Attachment 2  | HSC Pipeline Relocation Evaluation  |
| Attachment 3  | Climate Change and Sea-Level Rise Effects for the HSC ECIP Feasibility Study  |
| Attachment 4a | Engineering Data and Models - Houston Ship Channel and Vicinity Three-Dimensional Adaptive Hydraulics (AdH) Numerical Model Calibration/Validation Report |
| Attachment 4b | Houston Ship Channel Expansion Channel Improvement Project (ECIP) Numerical Modeling Report   |
| Attachment 5  | <i>Ship Maneuvering Simulation Study of Proposed Channel Modifications; HSC-ECIP Feasibility Study, Texas</i>   |
| Attachment 6  | <i>Slope Stability Analysis for BSC and BCC</i>   |
| Attachment 7  | <i>Slope Stability Analysis for Existing Placement Areas</i>  |
| Attachment 8  | Corps Shoaling Analysis Tool (CSAT) Report  |
| Attachment 9  | Sediment Training Options for the Bayport Flare in the Houston Ship Channel   |
| Attachment 10 | Channel Measure Volume Reports  |

## List of Acronyms

---

|          |   |
|----------|---|
| \$/CY    | Cost per cubic yard   |
| AC       | acres   |
| AdH      | Adaptive Hydraulics   |
| AdH-SW3  | Adaptive Hydraulics 3D shallow water module                           |
| ADM      | Agency Decision Milestone   |
| AM       | advance maintenance   |
| AO       | allowable overdepth   |
| AOM      | Assumption of Maintenance   |
| ASA      | Assistant Secretary of the Army                                       |
| ATON     | Aids to Navigation  |
| BC       | base condition  |
| BCC      | Barbours Cut Channel  |
| BCCT     | Barbours Cut Container Terminal                                       |
| BSC      | Bayport Ship Channel  |
| BU       | beneficial use  |
| BUG      | Beneficial Uses Group   |
| CDF      | confined disposal facility  |
| CO-OPS   | Center for Operational Oceanographic Products and Services            |
| CWCCIS   | Civil Works Construction Cost Index System                            |
| CWRB     | Civil Works Review Board  |
| CY       | cubic yards   |
| CY/YR    | cubic yards per year  |
| DMMP     | Dredged Material Management Plan                                      |
| DO       | dissolved oxygen  |
| EA       | Environmental Assessment  |
| EEB      | Estuarine Engineering Branch  |
| EIS      | Environmental Impact Statement  |
| EOP      | Environmental Operating Principles                                    |
| EPA      | U.S. Environmental Protection Agency                                  |
| ER       | Engineer Regulation   |
| ERDC     | Engineer Research and Design Center                                   |
| ERDC-CHL | Engineer Research and Design Center Coastal and Hydraulics Laboratory |
| ERGO     | Environmental Review Guide for Operations                             |
| FWOP     | future without project  |

|          |  |
|----------|--|
| FWP      | future with project  |
| FY       | fiscal year  |
| GBANC    | Galveston Bay Area Navigation Channel                      |
| GIWW     | Gulf Intracoastal Waterway                                 |
| GLO      | General Land Office  |
| GNF      | General Navigation Feature                                 |
| HP       | Houston Pilots   |
| HSC      | Houston Ship Channel                                       |
| HSC ECIP | Houston Ship Channel Expansion Channel Improvement Project |
| HTRW     | Hazardous, Toxic and Radioactive Waste                     |
| IFR-EIS  | Integrated Feasibility Report and Environmental Assessment |
| JV       | Joint Venture  |
| LOA      | length overall   |
| LSF      | local service facility                                     |
| MCNP     | Monitoring Completed Navigation Projects                   |
| MCY      | million cubic yards  |
| MLLW     | mean lower low water                                       |
| MLT      | mean low tide  |
| MSL      | Mean Sea Level   |
| MST      | mooring service type                                       |
| NAD83    | North American Datum of 1983                               |
| NEPA     | National Environmental Policy Act                          |
| NFS      | Non-Federal Sponsor  |
| NOAA     | National Oceanic and Atmospheric Administration            |
| NRC      | National Research Council                                  |
| O&M      | operations and maintenance                                 |
| ODMDS    | Ocean Dredged Material Disposal Site                       |
| PA       | placement area   |
| PDR      | Project Deficiency Report                                  |
| PDT      | Project Delivery Team                                      |
| PED      | Preconstruction Engineering and Design                     |
| PHA      | Port of Houston Authority                                  |
| POA      | period of analysis   |
| PSI      | pounds per square inch                                     |
| PTM      | partial tracking model                                     |
| RSLC     | relative sea level change                                  |
| SJMTTC   | San Jacinto Maritime Technology and Training Center        |

|           |   |
|-----------|---|
| SMMP      | Site Management and Monitoring Plan   |
| TCEQ      | Texas Commission on Environmental Quality   |
| TCOON     | Texas Coastal Ocean Observation Network   |
| TPWD      | Texas Parks and Wildlife Department   |
| TSP       | Tentatively Selected Plan   |
| TWDB      | Texas Water Development Board   |
| UFC       | United Facilities Criteria  |
| USACE     | United States Army Corps of Engineers   |
| USACE-SWG | United States Army Corps of Engineers Southwestern Division<br>Galveston District |
| USCG      | United States Coast Guard   |
| VF        | vertical foot   |
| VTSS      | Vessel traffic service  |

# 1 GENERAL

## 1.1 Introduction

The Joint Venture of Turner Collie & Braden Inc. and Gahagan & Bryant Associates, Inc. (JV) was retained by the Port of Houston Authority (PHA) to assist in the Houston Ship Channel Expansion Channel Improvement Project (HSC ECIP), in partnership with the U.S. Army Corps of Engineers (USACE). The study is being performed in response to the standing authority of Section 216 of the Flood Control Act of 1970, as amended, which authorizes studies to review the operation of completed Federal projects and recommend project modifications “...when found advisable due to significantly changed physical or economic conditions and to report thereon to Congress with recommendations on the advisability of modifying the structures or their operation, and for improving the quality of the environment in the overall public interest.”

The study focuses on six segments of HSC shown in Figure 1-1. Channel modifications evaluated in this study include widening, deepening, bend easings, multipurpose mooring facilities, turning basins, and shoaling attenuation features. The following sections outline the details of the study and do not include portions of the HSC system that are not studied for improvement/modification.

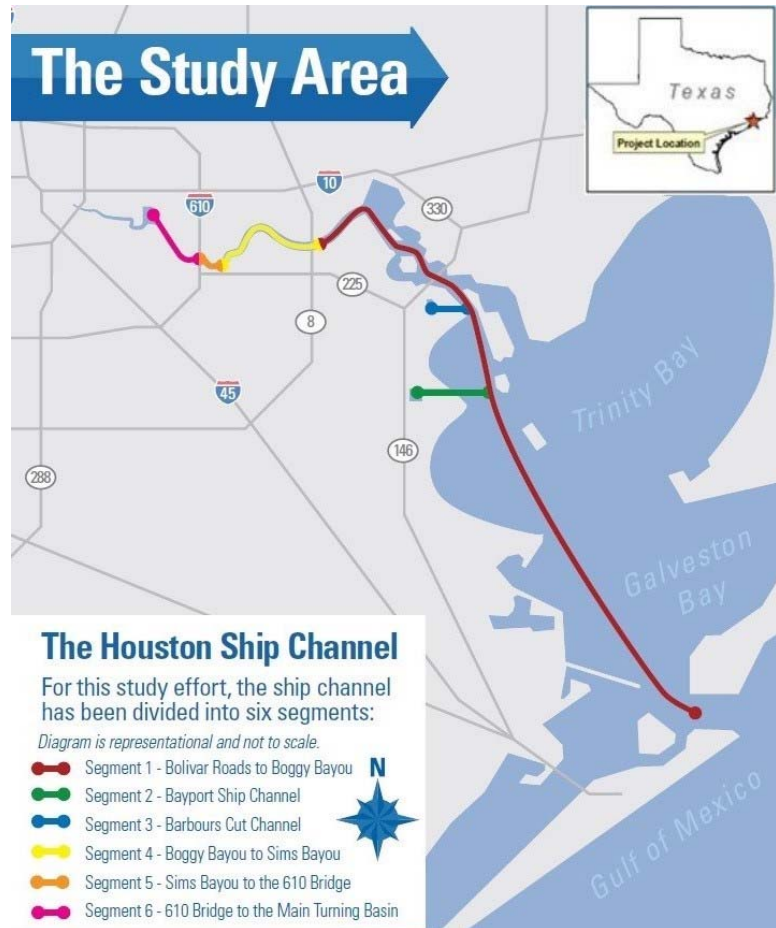

Figure 1-1: Six Study Segments of the HSC ECIP Feasibility Study

### 1.1.1 Segment 1: Bay Reach

Segment 1, the 46.5-Foot Project, extends from Bolivar Roads to Boggy Bayou. Segment 1 is separated into two sections, each divided further into three reaches with an authorized depth of -46.5 feet MLLW.

1. The Bay Section – This section begins at mile 0 at Bolivar Roads and extends to mile 26.2 at Morgans Point and is generally 530 feet wide with 235 feet of navigable barge space on either side of the channel. The 235 feet includes the transition from the channel to the barge lane at -13 feet MLLW. This section is divided into three reaches at each channel bend.
  - i. Lower Bay – Extends from Station 138+369 near Buoy 18 to Station 78+844 at Redfish Light 1, referred to as Bolivar Roads to Redfish.
  - ii. Mid Bay – Extends from Station 78+844 to Beacon 75/76 at Station 28+605, referred to as Redfish to BSC. The reach was mined to -52.5 feet MLLW during the construction of the 46.5 Project.
  - iii. Upper Bay – Extends from Station 28+605 to lower end Morgans Point Cut at Station 0+00, referred to as BSC to BCC. This reach was mined intermittently to depths ranging from -60 to -70 feet MLLW from Station 14+500 to 28+605 during construction of the PA 14/15 Expansion Project and construction of the Gorini Demonstration Marsh as part of the 46.5 Project.
2. The Bayou Section – This section begins at mile 26.2 at Morgans Point and extends to the end of Boggy Bayou at mile 38.5. The channel is approximately 530 feet wide and greater in the turns. The channel narrows to 400 feet for the last approximate 1.3 miles, west of the San Jacinto Monument to Boggy Bayou. This section is divided into three reaches. However, no improvements are proposed in this section of the channel as part of the study.
  - i. Lower Bayou – Extends from Station 0+05 to Station 295+00, referred to as the BCC to Exxon.
  - ii. Mid Bayou – Extends from Station 295+00 to 520+00, referred to as Exxon to Carpenters Bayou.
  - iii. Upper Bayou – Extends from Station 520+00 to 684+03, referred to as Carpenters Bayou to Boggy Bayou.

The study evaluates the need of selectively widening the existing 530-foot wide HSC to approximately 700-foot wide in the Bay Section to facilitate two-way traffic meeting by large vessels as well as the easing of the channel bends and turns associated with transit restrictions, slowdowns, and additional tug assist. Barge lanes will be replaced in-kind to their existing dimensions to the outside of the channel widening.



### **1.1.2 Segment 2: Bayport Ship Channel**

The 4.1-mile-long BSC is currently authorized to a 300-foot width and a depth of -41.5 feet MLLW. The PHA with authority under Sections 408 and 204(f) deepened the channel to -46.5 feet MLLW and widened the bay portions of the channel by 100 feet and widened the constricted portion of the channel within the land cut by 50 feet. The USACE recently assumed maintenance of the PHA improvements to the BSC Improvement Projects under Section 204 (f) of WRDA 86, as amended. The Feasibility Study analysis evaluates widening to a width of 455 feet. Other opportunities in this area include adding some form of jetty or structures to minimizing shoaling. The BSC was mined to -52.5 feet MLLW from Station 180+00 to the intersection of the HSC to provide construction materials for PAs 14 and 15 during the 46.5 Project.

One established safety issue was addressed under the HSC Project Deficiency Report (PDR), approved in May 2016, which recommended an interim corrective action at the HSC/BSC intersection with the ultimate fix requiring further evaluation as part of this Feasibility Study. During the study period the existing 3,000-foot radius flare was eased to a radius of 4,000 feet and ease the HSC bend transition from Mid Bay to Lower Bay under the HSC PDR approval. If the HSC is not widened, the BSC Flare requires additional easing to an approximate 5,375-foot radius and the HSC bend at Station 28+605 would require additional easing as discussed further in this appendix. Vessels entering the BSC typically do so with tug assistance due to the reduction in speed and the sharp turn necessary to safely enter the channel. This Feasibility Study considers a potential solution to improve this issue.

### **1.1.3 Segment 3: Barbours Cut Channel**

The 1.6-mile-long BCC is currently authorized to a depth of -41.5 feet MLLW. The PHA with authority under Sections 408 and 204(f) deepened the channel to -46.5 feet MLLW and shifted the channel 75 feet north to accommodate a wider berthing area. To accommodate the shift, the channel was excavated 75 feet to the north between Station 20+13 and 65+43 to maintain a 300-foot channel bottom width. The USACE recently assumed maintenance of the PHA improvements to the BCC Improvement Projects under Section 204 (f) of WRDA 86, as amended. The Feasibility Study analysis evaluates widening the channel to 455 feet. Other opportunities in this area evaluate the need for open water turning basin and flare improvements. The BCC was mined to -55.5 feet MLLW as part of deferred environmental restoration on the 46.5 Project.

### **1.1.4 Segment 4: Boggy Bayou to Sims Bayou**

This segment consists of two reaches. Boggy Bayou to Greens Bayou extends from channel Station 684+03 to Station 833+05. Greens Bayou to Sims Bayou extends from Station 833+05 to 1110+77. This analysis evaluates deepening the 8-mile portion of the HSC from Boggy Bayou to Sims Bayou to five feet beyond the existing -41.5 feet MLLW and widening between Boggy Bayou

to Greens Bayou to a width of 530 feet. The portion of the channel between Boggy Bayou and Sims Bayou is a narrow, highly industrialized area that is closely bordered on both sides by berths, docking facilities and other Port of Houston infrastructure.

### **1.1.5 Segment 5: Sims Bayou to I-610 Bridge**

This analysis evaluates deepening the 1-mile portion of the HSC from Sims Bayou to the I-610 Bridge four feet beyond the existing -37.5 feet MLLW. Widening of the channel was not ultimately considered due to apparent constrictions from surrounding structures and industry. The portion of the channel between Sims Bayou and the I-610 Bridge is a narrow, highly industrialized area that is closely bordered on both sides by berths, docking facilities and other Port of Houston infrastructure.

### **1.1.6 Segment 6: I-610 Bridge to Turning Basin**

This analysis evaluates deepening of the 2.5-mile portion of the HSC from the I-610 Bridge through the Main Turning Basin to four feet beyond the existing -37.5 feet MLLW. Widening of the channel was not ultimately considered due to apparent constrictions from surrounding structures and industry. Study Segments 5 and 6 lies within the HSC channel reach known as Sims Bayou to Turning Basin from Station 1110+77 to Station 1266+48.

## **1.2 Physical Description of the Existing Project**

The HSC provides access to various private and public docks and berthing areas associated with the Port of Houston. It is the longest major navigation channel of a larger system of navigation channels of the Galveston Bay Area (herein referred to as (GBANC) system) located in Harris, Chambers and Galveston Counties, Texas. Associated side channels of the HSC include the BSC, BCC, San Jacinto and Greens Bayou Channels. Other major channels included in the GBANC are the Galveston Harbor and Channels and the Texas City Ship Channel, which provide access to the Ports of Galveston and Texas City, respectively, as well as the Cedar Bayou Navigation Channel which provides shallow water access to Cedar Bayou.

The original authorization for the channels was relative to Mean Low Tide (MLT). Galveston District recently converted the HSC to the Mean Lower Low Water (MLLW) datum. See Section 2.1 Datums for a description of the conversion from MLT to MLLW. Depths in the report are referenced to MLLW unless otherwise stated. Table 1-1 provides the project depths in both datums and a summary of the channel dimensions (depth, width, and length) for the HSC, its tributary channels, and turning basins.

Table 1-1: Channel Dimensions for HSC and Tributaries

| HSC Section of Waterway  | Authorized Dimensions |         |                        |                |
|--|-----------------------|---------|------------------------|----------------|
|  | Depth (feet)          |         | Width (feet)           | Length (miles) |
|  | MLT                   | MLLW    |                        |                |
| <b>SEGMENT 1 – HSC-BAY REACH SAFETY AND EFFICIENCY ENHANCEMENTS</b>      |                       |         |                        |                |
| -Bolivar Roads (Mile 0) to Morgans Point (Mile 26.2) <sup>1</sup>        | 45                    | 46/46.5 | 530                    | 26.2           |
| -Barge Lanes (adjacent to and on each side from Mile 0 to Mile 26.2)     | 12                    | 13      | 125                    | 26             |
| -Morgans Point (Mile 26.2) to Boggy Bayou (Mile 38.5)                    | 45                    | 46.5    | 530-600                | 12.3           |
| -South Boaters Cut @ Mile 15.3   | 8                     | 9       | 300                    | 1.9            |
| -North Boaters Cut @ Mile 18.7   | 8                     | 9       | 100                    | 2.1            |
| -Five Mile Cut Channel @ Mile 20.9                                       | 8                     | 9       | 125                    | 1.9            |
| <b>SEGMENT 2 – BAYPORT SHIP CHANNEL</b>                                  |                       |         |                        |                |
| -Bayport Ship Channel (Mile 21.4 at intersection with HSC) <sup>3</sup>  | 40                    | 41.5    | 300                    | 3.8            |
| Turning Basin  | 40                    | 41.5    | 300-1,600              | 0.3            |
| <b>SEGMENT 3 – BARBOURS CUT CHANNEL</b>                                  |                       |         |                        |                |
| -Barbours Cut Channel (Miles 26.3 at intersection with HSC) <sup>3</sup> | 40                    | 41.5    | 300                    | 1.1            |
| Turning Basin  | 40                    | 41.5    | 300-1,600              | 0.3            |
| <b>SEGMENT 4 –BOGGY BAYOU TO SIMS BAYOU</b>                              |                       |         |                        |                |
| -Boggy Bayou (Mile 38.5) to Greens Bayou (Mile 42.0)                     | 40                    | 41.5    | 300                    | 3.5            |
| -Jacintoport Channel   | 40                    | 41.5    | 200                    | 0.7            |
| -Greens Bayou (Mile 42.0) to Sims Bayou (Mile 47.5)                      | 40                    | 41.5    | 300                    | 5.5            |
| Hunting Bayou Turning Basin  | 40                    | 41.5    | 948-1,000 <sup>2</sup> | 0.3            |
| Clinton Island Turning Basin   | 40                    | 41.5    | 965-1,070 <sup>2</sup> | 0.3            |
| -Greens Bayou Channel Mile 0.0 to Mile 0.36                              | 40                    | 41.5    | 175                    | 0.4            |
| -Greens Bayou Channel Mile 0.36 to Mile 1.65                             | 15                    | 16.5    | 100                    | 1.3            |
| <b>SEGMENT 5 –SIMS BAYOU TO I-610 BRIDGE</b>                             |                       |         |                        |                |
| -Sims Bayou (Mile 47.5) to I-610 Bridge (Mile 48.3)                      | 36                    | 37.5    | 300                    | 0.8            |
| <b>SEGMENT 6 –I-610 BRIDGE TO MAIN TURNING BASIN</b>                     |                       |         |                        |                |
| -I-610 Bridge (Mile 48.3) to Houston (Main) Turning Basin (Mile 50.2)    | 36                    | 37.5    | 300                    | 1.9            |
| Houston (Main) Turning Basin   | 36                    | 37.5    | 400-932                | 0.6            |
| Upper Turning Basin  | 36                    | 37.5    | 150-527                | 0.2            |
| Brady Island Channel   | 10                    | 11      | 60                     | 0.9            |
| Brady Island Turning Basin   | 36                    | 37.5    | 300-722                | 0.2            |
| Buffalo Bayou Light Draft Channel  | 10                    | 11      | 60                     | 4.1            |
| Turkey Bend Channel  | 10                    | 11      | 60                     | 0.8            |

<sup>1</sup> Per the MLT to MLLW Datum Conversion, the split occurs at Beacon 76.

<sup>2</sup> Includes 300-foot channel width

<sup>3</sup> PHA received approval to deepen channel to 46.5 feet MLLW and subsequent Federal Assumption of Maintenance (AOM) under Section 408/204(f). BSC deepening was completed in Fall of 2016 and BCC was completed in August 2015. Additionally, the BSC was widened from 300 feet to 400 feet from the BSC Flare to the land cut and from 300 feet to 350 feet from the land cut to the BSC Turning Basin.

### 1.3 Current Channel Restrictions

The HSC system is currently suffering inefficiencies due to its current channel configuration. The system has constrained vessel sizes, draft restricted areas in the upper channel, inadequate channel configurations for vessels currently using the channel, and these inefficiencies are contributing to congestion along the waterway, especially with the high volume of barge and deep-draft vessel traffic on the HSC. The HSC is a high use channel and one of the busiest waterways in the United States with over 9,000 deep draft and over 200,000 barge calls per year. The Houston Pilots (HP) is the entity that provides for the safe navigation along the HSC and its tributaries. As such, the

HP has promulgated rules and restrictions regarding the transit of various deep draft vessels in the system.

A summary of the working rules as they impose travel restriction are indicated below. Figure 1-2 identifies the location of the markers referenced in the HP working rules. The latest full description of HP Working Rules were updated on April 10, 2019, and are available at the following website: <http://houston-pilots.com/workingRules.pdf>.

- Maximum vessel size from Bolivar Roads to Barbour's Cut is 1,000 feet length overall (LOA) x 138 feet in beam (without additional restriction).
- Wide-Body Rules – This rule is predicated on the 530-foot wide channel and the completed barge lanes.
  - A wide-body vessel is defined as any vessel with a beam of 120 feet and over.
  - Any wide-body vessel transiting above Buoy 18 will require two pilots at all times.
  - Any wide-body tanker proceeding with cargo will be daylight restricted above Buoy 18.
  - Any wide-body vessel over 150 feet in beam and/or over 900 feet in LOA will be daylight restricted above Buoy 18 at all times.
  - The maximum LOA above Morgans Point High Lines is 950 feet without prior approval from the Houston Pilots and the respective terminal.
  - The maximum beam of any vessel allowed to come to Houston is 166 feet without prior approval from HP and the respective terminal.
  - Two wide-body vessels meeting in the HSC between Buoy 18 and Beacons 75/76 shall be restricted to a combined beam width of 310 feet and shall be limited to a combined draft of 85 feet.
  - Two wide bodies meeting in the HSC between Beacons 75/76 and Boggy Bayou shall be restricted to a combined beam of 272 feet and shall be limited to a combined draft of 77 feet.
- Loaded Suezmax tankers will not meet any vessel with a beam above 106 feet above Buoy
- Upon completion of the dredging project to widen the BSC to 400' outside the land cut and 350' inside the land cut, and of relocation of aids to navigation to mark the new channel, the maximum non-tank vessels permitted to transit the BSC is 1,096 feet LOA x 143-foot beam.

- Upon completion of the dredging project to increase the radius of the BSC Flare from 3,000' to 4,000' and to widen the east side of the HSC in the vicinity of Beacons 75/76, the maximum non-tank vessels permitted to transit the BSC is 1,160 feet LOA x 150-foot beam.
- The maximum size of a tank vessel permitted to transit the BSC and BCC is 850 feet LOA x 145-foot beam.
- Container vessels with dimensions greater than 1,100 feet LOA will not be met by any other ships in the HSC above B-18. Container vessels with dimensions less than or equal to 1,110 feet LOA and beam less than or equal to 150 feet may meet other vessels with dimensions less than or equal to 601 feet x 106 feet and a draft of less than 35 feet.
- Loaded Aframax tankers, approximately 850 feet LOA x 135-foot beam will not meet a larger, loaded vessel.
- Maximum vessel size from Boggy Bayou to Simms Bayou is 750 feet LOA x 116-foot beam and draft restricted to 41.5 feet.
- Vessels with beam greater than 105 feet shall not meet any ship vessel of any size above Boggy Bayou.
- All vessels greater than 750 feet LOA and a draft greater than 39 feet are daylight restricted above the Beltway 8 Bridge.
- Maximum draft from Simms Bayou to the Main Turning Basin is 37.5 feet.
- No car carrier of any size or any other vessel of 625 feet LOA or longer will arrive/depart City Docks #20-32 when required to turn at Brady Island Turning Basin when there is a vessel docked or encroached into City Dock #27.
- No vessel 580 feet LOA or longer loaded to more than 30-foot draft when required to turn at Brady Island Turning Basin will arrive/depart City Dock #20-32 when there is a vessel docked or encroached into City Dock # 27.



Figure 1-2: Location of Markers Referenced in HP Working Rules



## **2 EXISTING CONDITIONS**

---

### **2.1 Surveying, Mapping, and Other Geospatial Data Requirements**

#### **2.1.1 Surveys**

Conditional hydrographic channel surveys from 2016 to 2018 from the USACE supplemented with hydrographic surveys from the JV and NOAA were used for this study. Methodology for calculating channel volumes and further details about survey locations and dates are discussed in more detail in Section 5.1. During the PED phase, updated hydrographic surveys will be performed to better define the quantity of materials to be dredged. Additionally, hydrographic surveys shall extend approximately 1000 feet beyond the channel and barge lane toes on 1,000 foot intervals to track changes in channel side slopes and adjacent bay bottom over time for monitoring of channel conditions that relate to shoaling analysis.

#### **2.1.2 Mapping**

NOAA charts and aerial imagery from the Texas Natural Resources Information System of the vicinity was used during the initial and plan formulation phases. Planimetric CAD files of existing channel alignments and features were provided by the USACE and overlaid on to the background images.

#### **2.1.3 Datum**

The horizontal datum for the project is based on the Texas State Plane Coordinate System, South Central Zone 4204, North American Datum of 1983 (NAD83). The vertical datum is MLLW.

All prior projects in the Galveston District have used the USACE vertical datum MLT. The USACE has completed the process of converting the vertical datum for all navigation projects from MLT to MLLW (USACE, 2015a). From Bolivar Roads Station 138+369.011 to Beacon 76 at Station 28+605.055, MLLW is 1 foot above MLT, converting the -45-foot MLT project to -46 feet MLLW. From Station 28+605.055 to the termination of the HSC at the end of Main Turning Basin the conversion is 1.5 feet. The depths of the channels at -45, -40, -37 and -36 feet MLT are now -46.5, -41.5, -38.5 and -37.5 feet MLLW, respectively.

Separate from authorized channel depth conversions, actual survey data is converted between datums based on survey control monuments and not based on the channel conversions of 1 to 1.5 feet. Most all the survey data used in this Feasibility Study was provided by the USACE in MLLW. There were several instances in the BSC and BCC where surveys from previous projects in MLT were used to supplement gaps in the USACE data. To convert the survey data to MLLW the vertical datum relationships in Figure 2-1 were used.

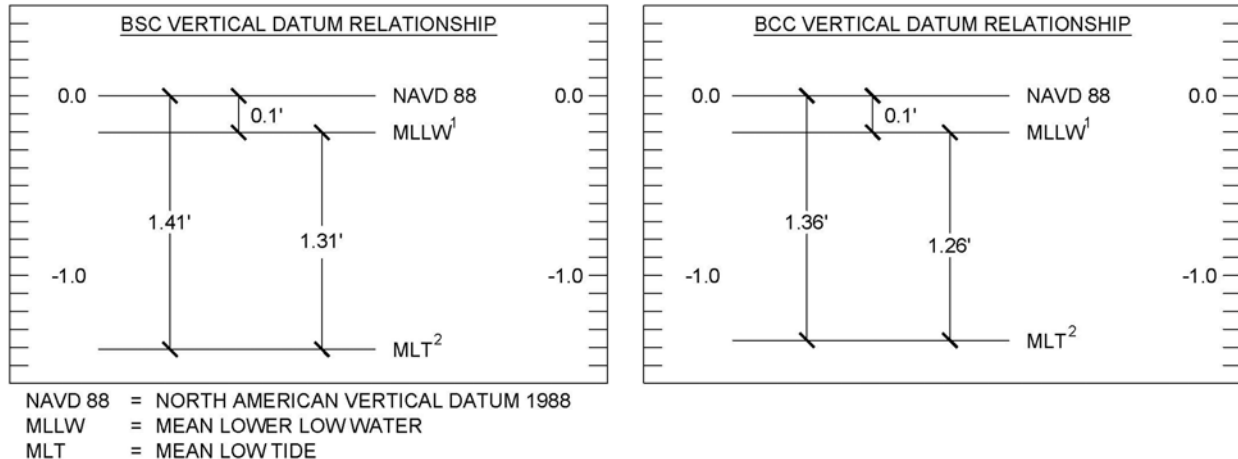

## NOTES:

<sup>1</sup> RELATIONSHIP BETWEEN MLLW AND NAVD88 IS FROM THE MORGANS POINT STATION 8770613

<sup>2</sup> RELATIONSHIP BETWEEN MLT AND NAVD88 PROVIDED BY THE USACE (MAY 2013)

Figure 2-1: BSC and BCC vertical datum relationship for converting survey data

## 2.2 Tides, Currents, Wind, Waves, and Water Level

The project area experiences semi-diurnal tides where two high and two low tidal periods occur each daily tidal cycle, with an average mean tidal range of approximately 1 foot. Elevated tidal surge is experienced in Galveston Bay during storm conditions and high spring tide events. From May to September the Galveston Bay experiences increased precipitation which drives freshwater input from Buffalo Bayou and the two largest river drainages, the Trinity and San Jacinto Rivers. These increased freshwater inputs typically result in the formation of a fresh/saltwater wedge concentrated in the deeper areas of Galveston Bay as well as navigational channels such as the HSC and BSC.

Water circulation and currents in Galveston Bay can also be affected by prevailing wind conditions, especially within the relatively shallower areas. The prevailing south and southeastern winds, typically experienced from spring through fall, force water against the mainland and create countercurrent eddies within the nearshore areas while north and northwest winds in the winter months cause bay water to push against the barrier of Galveston Island and Bolivar Peninsula. Due to the low capacity to inflow ratio and small tidal range, water entering Galveston Bay has a relatively long residence time, with flushing times ranging from 75 to 280 days for the entire bay and from 16 to 28 days in the HSC (Sparr et al., 2010).

Although Galveston Bay is typically a low-energy environment protected on the seaward side by a chain of barrier islands and peninsula with limited inlets, the area experiences a high level of storm activity. Multiple hurricanes and tropical storms in recent years have had a dramatic effect on the location, composition, and function of shorelines throughout the bay. Coastal flooding from hurricanes occurs when the effects of storm surge, driven by cyclonic winds and low pressure,



cause water to stack up at levels higher than normal ocean water-surface levels. Storm surge levels are highest when storm surge coincides with the astronomical high tide resulting in storm tide. Storm surge effects are greatest in shallower offshore waters. Therefore, the bathymetry that tends to exacerbate storm surge effects is that in shallower water.

Offshore surges were carried into various points around Galveston Bay. Surge levels for a variety of return periods were extracted at five locations along the HSC. The point locations and surge super-elevations are shown in Figure 2-2 below.

### HSC: Hazard Table at Extraction Points (98 % CI)

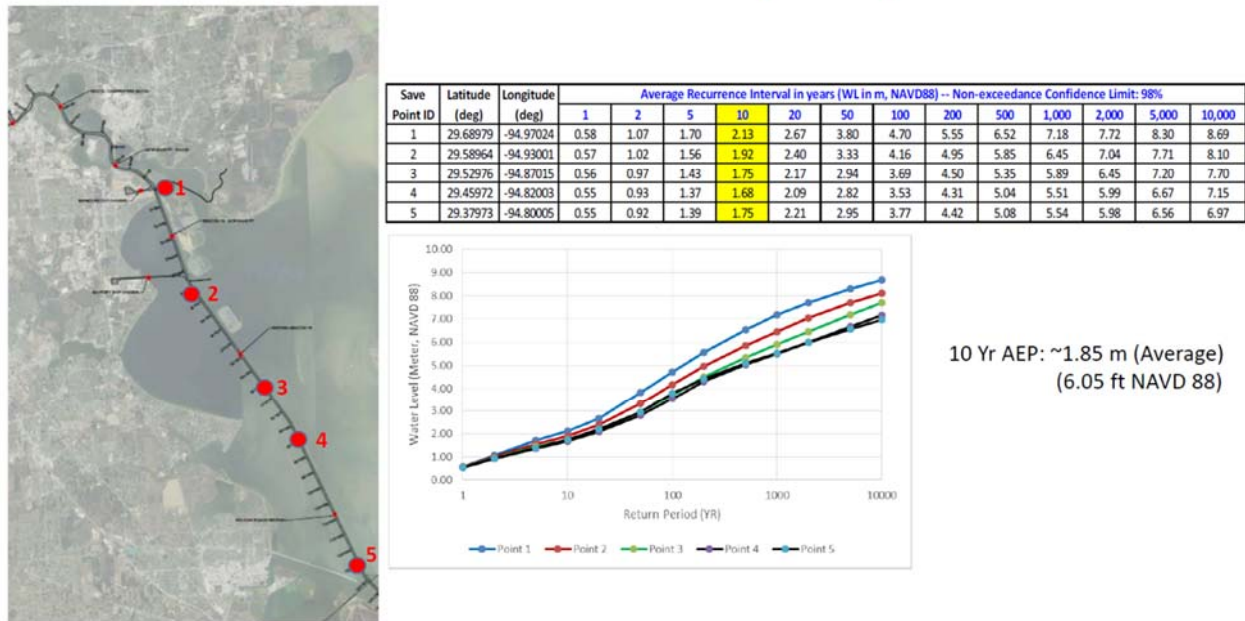

Figure 2-2: HSC: Hazard Table at Extraction Points

### 2.3 Relative Sea Level Change

For navigation projects, the general impacts of rising sea level are (1) extra depth in the navigation channel (a benefit), (2) the eventual need for higher dikes around placement areas (a cost), and (3) drowning of some plant species, if sea level rises fast. Economic benefit analysis is not calculated for the potential extra depth of the navigation channel as there is no policy that requires or allows it. Additionally, the majority of the existing and planned dikes are above +10 MLLW and upwards of +30. This is well above the expected sea level rise. For the BU sites, periodic nourishment is part of the DMMP in Appendix R and the quantities for placement have been calculated to account for RSLC. Bird islands and BU sites will be assessed for RSLC impacts, and addressed via adaptive management techniques if necessary. RSLC is not expected to affect the air draft of the economic design vessels that cross below the Fred Hartman and BW 8 Bridges as there is already 15 feet of air draft available which is more than the estimated RSLC. Additionally, there are ways vessel operators can mitigate for any additional restrictions as a result of RSLC such as ballasting.

However, the clearance of the 610 Bridge is 135 feet which limits the draft of the vessels that navigate under it. The vessel size is the same in the FWP and FWOP. Issues relating to the navigability under and through the bridge are the same in the FWP and FWOP condition. TXDOT has plans for bridge replacement in their master plan.

Results are summarized below. For the complete report, see Attachment 3 “Sea-Level Rise Effects for the HSC ECIP Feasibility Study.”

Rising sea levels due to changes induced by climate change are an impact of the environment on coastal project performance of increasing concern to the USACE. Relative Sea Level Change (RSLC) was evaluated using the current USACE guidance ER 1100-2-8162, *Incorporating Sea Level Change in Civil Works Programs* (USACE, 2013), and the Engineering Technical Letter ETL 1100-2-1, *Procedures to Evaluate Sea Level Change: Impacts, Responses, And Adaptation* (USACE, 2014). USACE guidance specifies evaluating alternatives using “low,” “intermediate,” and “high” rates of future sea level change.

- **Low** - Use the historic rate of local mean sea level change as the “low” rate (which is a straight line). The guidance further states that historic rates of sea level change are best determined by local tide records (preferably with at least a 40-year data record).
- **Intermediate** - Estimate the “intermediate” rate of local mean sea level change using the modified Nation Research Council’s (NRC) Curve I. It is corrected for the local rate of vertical land movement.
- **High** - Estimate the “high” rate of local mean sea level change using the modified NRC Curve III. It is corrected for the local rate of vertical land movement.

ETL 1100-2-1 recommends an expansive approach to considering and incorporating RSLC into civil works projects. It is important to understand the difference between the period of analysis (POA) and planning horizon. Initially, USACE projects are typically justified over a 50-year POA. However, USACE projects can remain in service much longer than the POA. The climate for which the project was designed can change over the full lifetime of a project to the extent that stability, maintenance, and operations may be impacted. Given these factors and for consistency with ER 1110-2-8159, *Life Cycle Design and Performance* (USACE, 1997), the project planning horizon considered for analyzing RSLC is 100 years.

Historic rates from the Center for Operational Oceanographic Products and Services (CO-OPS) at the National Oceanic and Atmospheric Administration (NOAA), which has been measuring sea level for over 150 years, were used in the analysis. This is consistent with USACE guidance that changes in Mean Sea Level (MSL) should be computed using gages with a minimum 40-year span of observations. The longest-running (from 1908 to present) tide gage in Galveston Bay is at Pier 21 (NOAA 8771450) in Galveston and is still active. These measurements have been averaged by

month to eliminate the effect of higher frequency phenomena such as storm surge, to compute an accurate linear sea level trend.

The MSL trends presented are local relative trends as opposed to the global (eustatic) sea level trend. Tide gauge measurements are made with respect to a local fixed reference level on land; therefore, if there is long-term vertical land motion occurring at that location such as subsidence, the relative MSL trend measured there is a combination of the global sea level rate and the local vertical land motion, also known as RSLC.

The Pier 21 tidal-gage data was utilized to determine the MSL trend from 1908 to 2013 which is estimated at 6.39 mm/year with a 95% confidence interval of  $\pm 0.24$  mm/year. NOAA estimates the MSL trend as 6.37 mm/year. Comparing the tide gauge change of RSLC with the network of subsidence gauges, it can be concluded that subsidence is about twice that of RSLC. The subsidence data also show that subsidence is decelerating slowly. It should be noted that the subsidence gauges are located on land in Harris County, while the tide gauge used for this analysis is located at Pier 21. Though these locations do not coincide, they are the best gauges available, so the assumption made is to apply the same respective trends in subsidence and RSLC from these two gauges throughout the Galveston region, and thus for this analysis.

In addition to the project period of analysis of 50 years and the RSLC planning horizon of 100 years, RSLC for the 25-year period was calculated, per ETL 1100-2-1. Table 2-1 presents the predicted level (MLLW) for the 25, 50 and 100-year periods.

Table 2-1: Summary of Relative Sea Level Change Estimates (Levels are relative to 1992 Zero)

| Year   | Low (feet) | Intermediate (feet) | High (feet) |
|--|------------|---------------------|-------------|
| 2023   | 1.20       | 1.29                | 1.56        |
| The anticipated project construction start year      |            |                     |             |
| 2029 (0 years)                                       | 1.33       | 1.45                | 1.83        |
| The anticipated project construction completion year |            |                     |             |
| 2054 (25 years)                                      | 1.85       | 2.19                | 3.28        |
| 2079 (50 years)                                      | 2.37       | 3.05                | 5.18        |
| 2129 (100 years)                                     | 3.42       | 5.09                | 10.38       |

Economic analysis did not assume any benefits from RSLC. It is still undetermined whether increased benefits in the channel from RSLC will be less than or more than the increased cost for PA dikes.

## 3 CHANNEL DESIGN CONSIDERATIONS

---

### 3.1 Design Vessels

The design vessels selected by the USACE were used to conduct an economic evaluation and to guide the engineering design of channel improvements. EM 1110-2-1613, *Hydraulic Design of Deep-Draft Navigation Projects* states "...the design ship or ships are selected on the basis of economic studies of the types and sizes of the ship fleet expected to use the proposed navigation channel over the project life..." (USACE, 2006). The design ship is defined as "...the largest ship of the major commodity movers expected to use the project improvements on a frequent and continuing basis..." For a full distribution and discussion of the current and future fleet forecasts of design vessels, consult Appendix B, Economics. As recommended in Appendix B, the following design vessels for each channel study segment are discussed below.

Eight design vessels were identified within the six study segments. The alternatives target improvements for those different design vessels throughout the HSC system. Ship simulations were conducted to determine the feasible dimensions of the channel after the Tentatively Selected Plan (TSP) per the 3x3x3 exemption approval for the HSC ECIP study. Final channel dimensions will be confirmed through more in-depth ship simulations during Preconstruction Engineering and Design (PED). Table 3-1 below provides the design vessels and study segments they are associated with.

Table 3-1: Design Vessels per Study Segment

| Segment | Type            | Class           | LOA   | Beam | Draft |
|---------|-----------------|-----------------|-------|------|-------|
| 1,2,3   | Containership   | Gen III         | 1,100 | 158  | 49    |
| 1,2,3   | Containership   | Gen III         | 1,200 | 140  | 49    |
| 1,2     | Tanker          | Suezmax         | 935   | 164  | 54    |
| 3,4     | Tanker          | Aframax         | 850   | 138  | 54    |
| 4       | Bulk Carrier    | Panamax         | 810   | 106  | 44    |
| 5       | Tanker          | Panamax size    | 610   | 106  | 44    |
| 5       | Vehicle Carrier | Ro-Ro           | 640   | 106  | 34    |
| 6       | Bulk Carrier    | 70k-110k Bulker | 750   | 106  | 45    |

EM 1110-2-1613 defines design vessel as "A hypothetical or real ship with dimensions of the largest vessels that a navigation project is designed to accommodate" (USACE, 2006, Glossary-11). It further states "For project improvement studies, a thorough review and analysis of ships presently using the project should be included as a part of the study. Projections of ship fleet data, usually needed, account for expected ship construction trends" (p. 3-10). "The design ship is chosen as the maximum or near-maximum-size ship in the range of ship sizes from the vessel fleet. The design dimensions of the channel will be determined to accommodate the design ship(s) representative of the project forecasted user fleet" (p. 3-11).

The largest potential container ship size is a hybrid of the 1,000 feet LOA x 158-foot beam and a 1,200-foot LOA x 140-foot beam. Therefore, a hybrid container ship size was selected to evaluate design considerations. The contemplated hybrid container ship is 1,200 feet LOA x 158-foot beam for sizing the BSC and BCC and a hybrid of a 1,200 feet LOA x 164-foot beam was used to size the bend easing and widening of the HSC from Bolivar Roads to Morgans Point. The design vessels shown in Table 3-1 were considered for feasibility level ship simulation.

## 3.2 Channel Modifications

EM 1110-2-1613 provides guidelines to determine channel modifications based on average navigation conditions. Final design of channel improvements is typically confirmed with ship simulation. The basic requirements and guidelines used to determine the required channel improvements for bend easing, channel widening, mooring basins and turning basins are discussed further in this section. Section 4 provides more detailed calculations and design recommendations for these features and the measures developed to achieve them.

### 3.2.1 Bend Easings

The HP have expressed concerns with the ability to navigate vessels greater than 1,000 feet in length into and up the HSC to BSC and BCC. Of particular concern is the turns that the vessels make between each reach. Due to the ship length, vessels can cross from the red side to the green side when transiting inbound/outbound when making the turns. When returning from sea, heading upstream, or toward the origin/headwaters of a body of water, the right side of the channel will be marked with red aids-to-navigation (ATONS) and green on the left. The current channel and turn dimensions are not adequate for a containership greater than 1,000 feet in length.

EM 1110-2-1613 guidelines provided in Table 3-2 were consulted to determine channel bend requirements as a function of deflection angle, turn radius, and design ship length as shown in. Resulting channel configurations using these guidelines will be refined using ship simulation.

Table 3-2: Recommended Channel Turn Configurations

| Turn Type | Deflection Angle, $\delta$<br>(Degrees) | Turn Radius/Ship<br>Length (R/L) | Turn Width<br>Increase Factor |
|-----------|---|----------------------------------|-------------------------------|
| Angle     | 0-10                                    | 0                                | 0                             |
| Cutoff    | 10-25                                   | 3-5                              | 2-1                           |
| Apex      | 25-35                                   | 5-7                              | 1.0-0.7                       |
| Curved    | 35-50                                   | 7-10                             | 0.7-0.5                       |
| Circular  | >50                                     | >10                              | 0.5                           |

### 3.2.2 Channel Widening

The existing width determinations were made through several decision points that include environmental considerations, expert consultations, engineering constraints, and simulation during

the study phase of the Houston-Galveston Navigation Channel (HGNC) Project for deepening and widening.

Guidelines from EM 1110-2-1613 shown in Table 3-3 and Table 3-4 prescribes the following calculations for one-way and two-way traffic for design of channel widths as a function of channel type, current speeds, ATONS, channel cross-section, and design ship beam. Resulting channel configurations using these guidelines will be refined using ship simulation.

Table 3-3: One-Way Ship Traffic – Channel Width Design Criteria

| Uniform Cross Section                                       | Design Ship Beam Multipliers for Maximum Current |                         |                          |
|---|--|-------------------------|--------------------------|
|   | 0.0 to 0.5 knots<br>LOW                          | 0.5 to 1.5 knots<br>MED | 1.5 to 3.0 knots<br>HIGH |
| <b>Constant Cross Sections - Best Aids to Navigation</b>    |  |                         |                          |
| Canal   | 2.50   | 3.00                    | 3.50                     |
| Shallow   | 3.00   | 4.00                    | 5.00                     |
| Trench  | 2.75   | 3.25                    | 4.00                     |
| <b>Variable Cross Sections - Average Aids to Navigation</b> |  |                         |                          |
| Canal   | 3.00   | 3.50                    | 4.00                     |
| Shallow   | 3.50   | 4.50                    | 5.50                     |
| Trench  | 3.50   | 4.00                    | 5.00                     |

Table 3-4: Two-Way Ship Traffic – Channel Width Design Criteria

| Uniform Cross Section                                    | Design Ship Beam Multipliers for Maximum Current |                         |                          |
|--|--|-------------------------|--------------------------|
|  | 0.0 to 0.5 knots<br>LOW                          | 0.5 to 1.5 knots<br>MED | 1.5 to 3.0 knots<br>HIGH |
| <b>Constant Cross Sections - Best Aids to Navigation</b> |  |                         |                          |
| Canal  | 4.00   | 4.50                    | 5.50                     |
| Shallow  | 5.00   | 6.00                    | 8.00                     |
| Trench   | 4.50   | 5.50                    | 6.50                     |

### 3.2.3 Turning Basins

Mooring facilities have been requested for multiple uses including vessel lay berthing/queueing and for a harbor of refuge. Additionally, turning basins are needed for ship turning movements to facilitate safe passages for both channel traffic as well as ingress/egress of considered mooring facilities. EM 1110-2-1613 prescribes minimum dimension requirements that can be applied to the needs of facilities on an individual basis (design vessel size and quantities).

For turning basins, circular areas are overlain into smooth geometric linear extensions of channel toes. Whether the turning circles are to include the channel width or be installed completely outside of the existing limits is a matter of design discretion based on traffic safety requirements. The required size of a turning circle is a function of the design ship length and predominant water



currents of the area. Water currents vary between 0.5 knots to 1.5 knots throughout the project area. For this, the manual prescribes a multiplication factor of 1.5 times the ship length for the required turning circle size unless specifically verified by ship simulation.

### 3.3 Channel Slope Stability Analysis

The existing channel slopes for this project range from 2.5 horizontal to one vertical (2.5H:1V) to 5H:1V. For construction of channel modifications, the historic practice is to utilize a template with 3H:1V slopes. The maintenance templates are maintained on a 2.5H:1V slope. These slopes have been used for the HSC in all previous dredging contracts without any noted problems. During PED, additional geotechnical data will be gathered using various means and methods and detailed analyses will be performed to verify the stability of the side slopes due to the increased dredging depth and/or width.

An April 08, 2019 memo was released by the USACE-SWG regarding district policy on setting dredging templates for studies, new work construction projects, and channel maintenance. The updated policy follows guidance from ER 1130-2-520 and EP 1130-2-520, with the objective to standardize new work dredging templates and ensure that all new work material be removed from the future O&M template. Required depth will include authorized project depth, required advance maintenance, and required OD to include side slopes (Figure 3-1). Required OD and additional allowable OD will be based on the type of material encountered and can vary within the same channel. These modifications will be evaluated further in PED based on geotechnical properties.

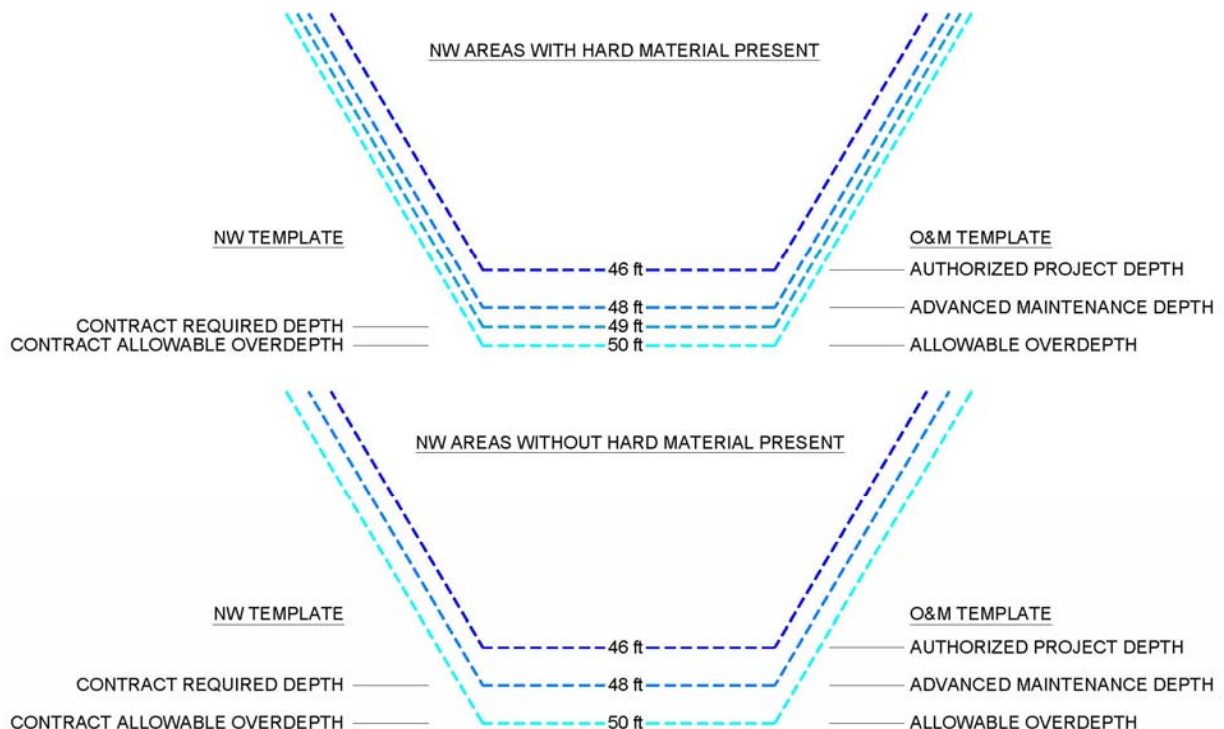

Figure 3-1: New work and O&M Dredging Templates Modified for SWG Policy.

## 4 MEASURES EVALUATED

---

The various channel modifications considered for the Recommended Plan (RP) are outlined in Table 4-1 and further detailed in the following sections. These include bend easings, channel widening and deepening, turning basins, and moorings. Measures evaluated for the TSP that were not carried forward to the RP are detailed in the Draft Engineering Appendix (USACE, 2017). Due to the large number of measures developed, an abbreviated designation was given to each type of measure along with the segment number, an approximate channel reference to the measure location, and a size of the measure (i.e. widened dimension, turning circle dimension, etc.). Descriptive designators were determined for the measures as follows:

**[Measure Type][Segment]\_[Location Information]\_[Size (if applicable)]**

The following nomenclatures are thus used for the measure designations discussed in subsequent sections:

- Measure Type:
  - BE – Bend Easing
  - CW – Channel Widening (includes deepening where applicable)
  - CD – Channel Deepening (deepening only, no widening)
  - TB – Turning Basin
  - SA – Sediment Attenuation
- Segment:
  - 1-6 for Study segments 1-6
- Location Information:
  - Denotes abbreviated reaches (i.e. BR-Redfish for Bolivar Roads to Redfish) or approximate channel reference station for mid-point locations of features for bends, turning basins, and mooring measures
- Size:
  - Where multiple sizes of features were considered (i.e. widening widths, turning basin circle diameters, etc.) the size evaluated was noted at the end of the measure designation. In text, where a measure is discussed in terms of generality, the size designator may or may not be listed.



Table 4-1: Measures Evaluated

| Channel Segment | Channel Section                        | Bend Easings (Section 4.1) | Channel Widening (Section 4.2)                   | Channel Deepening (Section 4.3)       | Turning Basin (Section 4.4)       |
|-----------------|--|----------------------------|--|---------------------------------------|-----------------------------------|
| 1               | 1a - Bolivar Roads to Redfish          | BE1_138+369<br>BE1_128+731 | CW1_BR-Redfish_700                               |                                       |                                   |
|                 | 1b - Redfish to BSC                    | BE1_78+844                 | CW1_Redfish-BSC_700                              |                                       |                                   |
|                 | 1c - BSC to BCC                        | BE1_28+605                 | CW1_BSC-BCC_700                                  |                                       |                                   |
| 2               | BSC                                    | BE2_BSCFlare               | CW2_BSC_455                                      |                                       |                                   |
| 3               | BCC                                    | BETB3_BCCFlare_1800NS      | CW3_BCC_455                                      |                                       | Combined with bend easing measure |
| 4               | Boggy Bayou to Greens Bayou            |                            | CW4_BB-GB_530<br>(Deepen 5FT) 46.5', +2 AM, +1AO |                                       |                                   |
|                 | Greens Bayou to Sims Bayou             |                            |  | CD4_Whole<br>(5FT) 46.5', +2 AM, +1AO |                                   |
| 5               | Sims Bayou to I-610 Bridge             |                            |  | CD5_Whole<br>(4-FT) 41.5', +2AM, +1AO |                                   |
| 6               | I-610 Bridge to End Main Turning Basin |                            |  | CD6_Whole<br>(4-FT) 41.5', +2AM, +1AO | TB6_Brady_900                     |

## 4.1 Bend Easings

Bend easing were developed based on EM requirements and design vessels as discussed in Section 3.2.1. The following calculations in Table 4-2 were made for each vessel type:

Table 4-2: Calculated Bend Easing Requirements by Vessel Type

| Vessel Type | Vessel Length | Vessel Beam | L/B  | Turn Type | Deflection Angle, $\delta$ (Degrees) | Turn Radius/Ship Length (R/L) |      | Turn Width Increase Factor (Ship Beam) |     | Channel Width | Design Turn Radius |       | Design Turn Width Increase |       |
|-------------|---------------|-------------|------|-----------|--------------------------------------|-------------------------------|------|--|-----|---------------|--------------------|-------|----------------------------|-------|
|             |               |             |      |           |                                      |                               |      |  |     |               |                    |       |                            |       |
| Aframax     | 850           | 138         | 6.16 | Angle     | 0-10                                 | 0.0                           |      | 0                                      |     | 530           | 0                  |       | 0                          |       |
|             |               |             |      | Cutoff    | 10-25                                | 3.0                           | 5.0  | 2.0                                    | 1.0 | 530           | 2550               | 4250  | 276                        | 138   |
|             |               |             |      | Apex      | 25-35                                | 5.0                           | 7.0  | 1.0                                    | 0.7 | 530           | 4250               | 5950  | 138                        | 96.6  |
|             |               |             |      | Curved    | 35-50                                | 7.0                           | 10.0 | 0.7                                    | 0.5 | 530           | 5950               | 8500  | 96.6                       | 69    |
|             |               |             |      | Circular  | >50                                  | 10.0                          |      | 0.5                                    |     | 530           | 8500               |       | 69                         |       |
| Suezmax     | 935           | 164         | 5.70 | Angle     | 0-10                                 | 0.0                           |      | 0                                      |     | 530           | 0                  |       | 0                          |       |
|             |               |             |      | Cutoff    | 10-25                                | 3.0                           | 5.0  | 2.0                                    | 1.0 | 530           | 2805               | 4675  | 328                        | 164   |
|             |               |             |      | Apex      | 25-35                                | 5.0                           | 7.0  | 1.0                                    | 0.7 | 530           | 4675               | 6545  | 164                        | 114.8 |
|             |               |             |      | Curved    | 35-50                                | 7.0                           | 10.0 | 0.7                                    | 0.5 | 530           | 6545               | 9350  | 114.8                      | 82    |
|             |               |             |      | Circular  | >50                                  | 10.0                          |      | 0.5                                    |     | 530           | 9350               |       | 82                         |       |
| LPG         | 738           | 121         | 6.10 | Angle     | 0-10                                 | 0.0                           |      | 0                                      |     | 530           | 0                  |       | 0                          |       |
|             |               |             |      | Cutoff    | 10-25                                | 3.0                           | 5.0  | 2.0                                    | 1.0 | 530           | 2214               | 3690  | 242                        | 121   |
|             |               |             |      | Apex      | 25-35                                | 5.0                           | 7.0  | 1.0                                    | 0.7 | 530           | 3690               | 5166  | 121                        | 84.7  |
|             |               |             |      | Curved    | 35-50                                | 7.0                           | 10.0 | 0.7                                    | 0.5 | 530           | 5166               | 7380  | 84.7                       | 60.5  |
|             |               |             |      | Circular  | >50                                  | 10.0                          |      | 0.5                                    |     | 530           | 7380               |       | 60.5                       |       |
| Tanker      | 610           | 106         | 5.75 | Angle     | 0-10                                 | 0.0                           |      | 0                                      |     | 530           | 0                  |       | 0                          |       |
|             |               |             |      | Cutoff    | 10-25                                | 3.0                           | 5.0  | 2.0                                    | 1.0 | 530           | 1830               | 3050  | 212                        | 106   |
|             |               |             |      | Apex      | 25-35                                | 5.0                           | 7.0  | 1.0                                    | 0.7 | 530           | 3050               | 4270  | 106                        | 74.2  |
|             |               |             |      | Curved    | 35-50                                | 7.0                           | 10.0 | 0.7                                    | 0.5 | 530           | 4270               | 6100  | 74.2                       | 53    |
|             |               |             |      | Circular  | >50                                  | 10.0                          |      | 0.5                                    |     | 530           | 6100               |       | 53                         |       |
| Cargo       | 797           | 105         | 7.59 | Angle     | 0-10                                 | 0.0                           |      | 0                                      |     | 530           | 0                  |       | 0                          |       |
|             |               |             |      | Cutoff    | 10-25                                | 3.0                           | 5.0  | 2.0                                    | 1.0 | 530           | 1830               | 3050  | 210                        | 105   |
|             |               |             |      | Apex      | 25-35                                | 5.0                           | 7.0  | 1.0                                    | 0.7 | 530           | 3050               | 4270  | 105                        | 73.5  |
|             |               |             |      | Curved    | 35-50                                | 7.0                           | 10.0 | 0.7                                    | 0.5 | 530           | 4270               | 6100  | 73.5                       | 52.5  |
|             |               |             |      | Circular  | >50                                  | 10.0                          |      | 0.5                                    |     | 530           | 6100               |       | 52.5                       |       |
| Container   | 1100          | 158         | 6.96 | Angle     | 0-10                                 | 0.0                           |      | 0                                      |     | 530           | 0                  |       | 0                          |       |
|             |               |             |      | Cutoff    | 10-25                                | 3.0                           | 5.0  | 2.0                                    | 1.0 | 530           | 3300               | 5500  | 316                        | 158   |
|             |               |             |      | Apex      | 25-35                                | 5.0                           | 7.0  | 1.0                                    | 0.7 | 530           | 5500               | 7700  | 158                        | 110.6 |
|             |               |             |      | Curved    | 35-50                                | 7.0                           | 10.0 | 0.7                                    | 0.5 | 530           | 7700               | 11000 | 110.6                      | 79    |
|             |               |             |      | Circular  | >50                                  | 10.0                          |      | 0.5                                    |     | 530           | 11000              |       | 79                         |       |
| Container   | 1200          | 140         | 8.57 | Angle     | 0-10                                 | 0.0                           |      | 0                                      |     | 530           | 0                  |       | 0                          |       |
|             |               |             |      | Cutoff    | 10-25                                | 3.0                           | 5.0  | 2.0                                    | 1.0 | 530           | 3300               | 5500  | 280                        | 140   |
|             |               |             |      | Apex      | 25-35                                | 5.0                           | 7.0  | 1.0                                    | 0.7 | 530           | 5500               | 7700  | 140                        | 98    |
|             |               |             |      | Curved    | 35-50                                | 7.0                           | 10.0 | 0.7                                    | 0.5 | 530           | 7700               | 11000 | 98                         | 70    |
|             |               |             |      | Circular  | >50                                  | 10.0                          |      | 0.5                                    |     | 530           | 11000              |       | 70                         |       |

### 4.1.1 Segment 1

Potential design vessels include two different GEN III container vessels. The largest potential container ship size of 1,200 feet LOA x 158-foot beam is a hybrid of the 1,000 feet LOA x 158-foot beam and a 1,200-foot LOA x 140-foot beam. However, the widest beam ship is the Suezmax at 935 feet LOA x 164-foot beam. Both the length and beam factor into the design of the bends. The largest required bend easing is a minimum of 164 feet to a maximum of 328 feet as highlighted in Table 4-2. Ship simulations were conducted to determine the feasible dimensions of the channel after the TSP per the 3x3x3 exemption approval for the HSC ECIP study. Final channel dimensions will be confirmed through more in-depth ship simulations during PED. For screening purposes, the bend easing of 328 feet is used throughout the analysis for the bend easings in the Bay sections of the project.

As all the angles of deflection are greater than 10 degrees, less than 25 degrees turn type will be cutoff based on Suezmax vessel, according to the EM guidance bend easings should be in place in the current channel condition. It is recognized that the barge lanes will be relocated outside of the bend easings.

Using the EM guidance, cutoff bend easings to facilitate and ensure navigational safety were developed for Segment 1 at each of the bends that occur from the intersection of the HSC and Galveston Harbor to the BSC near Beacon 76 as shown in Figure 4-1. Bend easings at these locations were developed for the existing 530-foot channel and channel widening measures discussed in the following sections. The bend easing measures developed in the Bay reach include:

- BE1\_138+369
- BE1\_128+731
- BE1\_78+844
- BE1\_28+605



Figure 4-1: Segment 1 Bay Reach Bend Easing Measures for the Existing 530-foot channel

### 4.1.2 Segment 2

A bend easing was developed to widen the south side BSC flare at its intersection with the HSC. The measure, **BE2\_BSCFlare** would ease the south flare from its existing radius of 4,000 feet to 5,375 feet as shown in Figure 4-2. Under a separate authority for the HSC PDR, the southern portion of the BSC Flare was eased to 4,000 feet, and the HSC adjacent to the Flare was widened by 235 feet to the east between HSC Station 26+484 and 30+090 as an interim fix. Further evaluation of this intersection was recommended as part of this study. Consultation with HP indicated that the 4,000-foot radius is efficient for a Maersk A type container ship (1,160 feet LOA x 150-foot beam), which was evaluated for the PDR, but would also require other components such as a wider channel with larger turning basins, larger dog leg turns in the HSC, and the potential for an additional turning basin near the BSC RO/RO Terminal. The Maersk A type vessel is similar to the HSC-ECIP design vessels. These additional considerations would allow for the largest expected container vessels to transit from the HSC to the BSC with minimal restriction and are considered in the formulation of alternative.

Based on the feedback from the HP, the 4,000-foot BSC flare with an additional modification to tie into the 700-foot HSC channel with 328-foot bend easings, and the BSC widening to 455 feet were simulated with the hybrid design vessel (1,200 feet LOA x 158-foot beam) and the Suezmax design vessel (935 feet LOA x 164-foot beam). Results of the ship simulation found that this combination would allow for the successful transit of the design containership, assist tugs, and normal HSC vessel traffic. With these modifications, the 5,375-foot BSC Flare would not be required, which would reduce the additional mitigation and the anticipated increase in maintenance dredging and placement area (PA) costs for a larger flare in an area with high shoaling. However, if the HSC is not widened to 700 feet, the Flare modification to the suggested 5,375-foot radius and a 328-foot bend easing at the existing 530-foot HSC bend at station 28+605 would be required. The additional turning basin at the BSC RO/RO was not economically justified and was eliminated from further study. The BE2\_BSCFlare is further detailed in Engineering Plate No. 09.

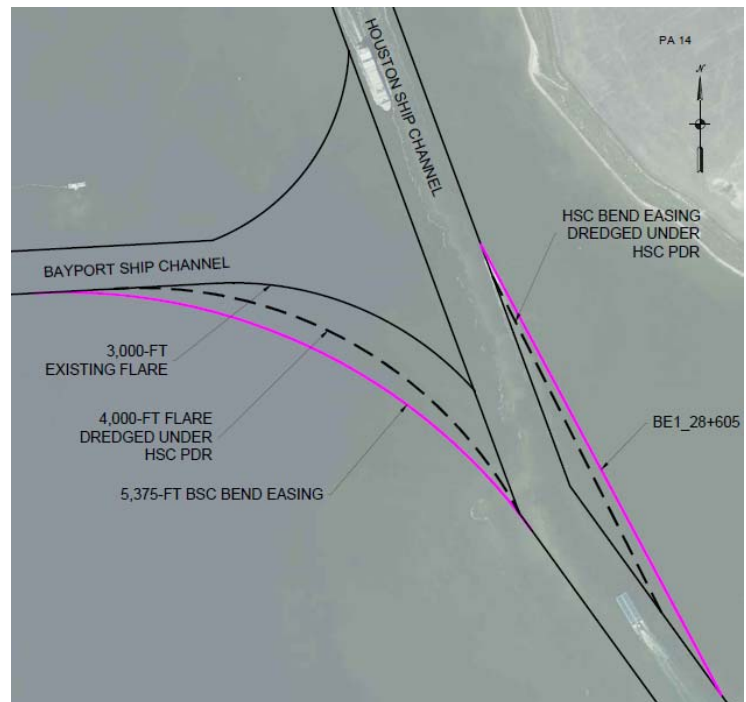

Figure 4-2: BSC Flare Easing 5,375 feet (BE2\_BSCFlare)

### 4.1.3 Segment 3

The HP have requested the ability to completely turn a vessel at the entrance to the BCC to back larger container vessels into Docks 1 or 2. This would reduce issues with passage of moored vessels further down the narrow channel by allowing them to turn around at the entrance and immediately dock at the facility. Options were considered for increasing the existing flare on the north side as well as creating a flare on the south side. A combination bend easing/turning basin was developed for the BCC, to facilitate ingress between the channel and the HSC. This measure, **BETB3\_BCCFlare\_1800NS**, considers easing the flare on the north side of the BCC entrance and creating a flare to the south as shown in Figure 4-3. Currently, vessels entering the BCC from the south make a sharp tug assisted turn into the BCC using the north side flare to turn and enter the channel. To safely make the turn into the BCC, the entrance needs modification. To determine the size needed for the turns, the standard turning basin calculations were utilized. The typical current at the entrance to Morgan's Point is approximately 1.5 feet/second (0.89 knots) using the NOAA Morgan's Point gauge. A turning basin in a mid-current range would require an 1,800-foot diameter for vessels with 1,200 feet LOA. This increment would allow for safer transit from the HSC into the BCC as well as a turning basin at the mouth of the BCC for both the 1,100 feet and 1,200 feet LOA container vessels.

Ship simulation of the BCC Flare easing and 700-foot HSC widening allowed for the design containership to successfully turn at the entrance to BCC and back into the dock, and to successfully exit the BCC. Transit of Suezmax tankers inbound and outbound of the BCC were considered acceptable, however it is recommended that transitioning between facilities north of Morgans Point and BCC be evaluated further in PED. In all cases three tugs are considered required and wind limits of 15 knots maximum should be observed.

This increment does not require dredging on the east side of the HSC, however it could potentially impede future development of the PHA facilities on the south side of the channel at Morgan's Point. In 1977, there were several mooring structures situated on the north side of the BCC flare that were cut at the mudline and removed. Any improvements to the north flare of the channel would require their total removal. The LASH dock on the southern side of the flare has been removed since the aerial photo was taken. Additionally, scattered oyster reef is located to the north as discussed Appendix P of the FSEIS. The **BETB3\_BCCFlare\_1800NS** is further detailed in Engineering Plate No. 10 and 26.



Figure 4-3: BETB3\_BCCFlare\_1800NS – BCC Flare Easing and 1,800-Foot Turning Basin

## 4.2 Channel Widening

Multiple channel widening scenarios have been evaluated to meet the needs of the existing and future shipping traffic. There are three different channel types defined in the EM 110-2-1613, canal, trench, and shallow. The HSC channel would be classified as a dredged channel trench as shown in Figure 4-4 (USACE, 2006, p. 8-3).

Typical current speeds in the area can be in the range of 0.5 to 1.5 knots (medium current speed range) as shown at observation stations located at the Fred Hartman Bridge and Morgan’s Point. Using the design recommendation from EM 1110-2-1613 referenced in Table 4-4 for two-way traffic and assuming a best level of ATONS, vessel beam combinations were evaluated to make design recommendations for width of the channel using various sized ships anticipated to frequently transverse the HSC. Results of these four tests are shown in Table 4-3 and show the EM guidance channel widths based on the channel type, current speed, design vessel beam widths, one-way versus two-way traffic, and ATONS.

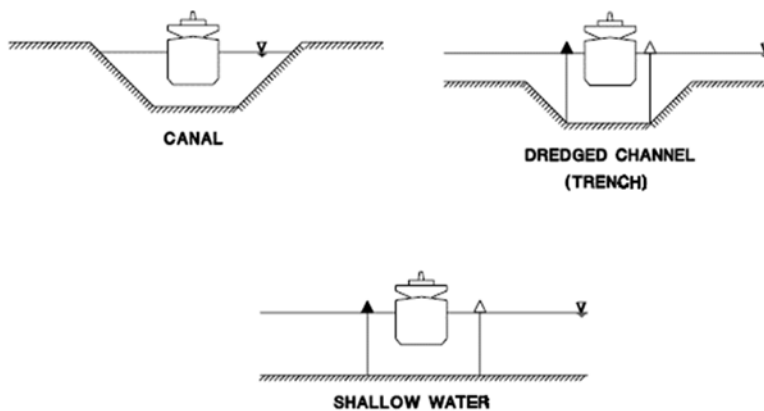

Figure 4-4: Channel Types Defined in EM 110-2-1613



Table 4-3: HSC Test Cases – Channel Width Design Criteria

|  | Channel Cross Section |             | Trench Type Channel Cross Section |             | Current (ft/s) |             | Medium Current Range<br>0.5 to 1.5 Knots |             |
|--|-----------------------|-------------|-----------------------------------|-------------|----------------|-------------|--|-------------|
|  | Bay Reach             |             | Bay Reach                         |             | Bay Reach      |             | Bay Reach                                |             |
|  | Beam (ft)             | Description | Beam (ft)                         | Description | Beam (ft)      | Description | Beam (ft)                                | Description |
| Vessel Beam <sub>design</sub> (ft)                                 | 164                   | Suezmax1    | 164                               | Suezmax1    | 164            | Suezmax1    | 164                                      | Suezmax1    |
| Vessel Beam <sub>traffic</sub> (ft)                                | 164                   | Suezmax1    | 158                               | Container   | 140            | Container   | 138                                      | Aframax     |
| <b>One-Way Best ATONS Multiplier Constant Cross Section</b>        | 3.25                  |             | 3.25                              |             | 3.25           |             | 3.25                                     |             |
| <i>Channel width (ft)</i>  | <b>533</b>            |             | <b>523</b>                        |             | <b>494</b>     |             | <b>491</b>                               |             |
| <b>One-Way Best ATONS Multiplier Variable Cross Section</b>        | 4.00                  |             | 4.00                              |             | 4.00           |             | 4.00                                     |             |
| <i>Channel width (ft)</i>  | <b>656</b>            |             | <b>644</b>                        |             | <b>608</b>     |             | <b>604</b>                               |             |
| <b>Two-Way Best ATONS Multiplier Uniform channel Cross Section</b> | 5.50                  |             | 5.50                              |             | 5.50           |             | 5.50                                     |             |
| <i>Channel width (ft)</i>  | <b>902</b>            |             | <b>886</b>                        |             | <b>836</b>     |             | <b>831</b>                               |             |

#### 4.2.1 Segment 1

Based on the results shown in Table 4-3 and discussions with the HP, channel widening scenarios ranging from 900 to 650 feet with 328-foot bend easings were evaluated for Segment 1. The 900 and 820-foot channels were not economically justified and were dropped at TSP and ADM. Ship simulations of the 650-foot channel widening concluded that the meeting of two design containerships would be a high-risk maneuver, and meetings between a design containership and tanker would be a risky maneuver. The meetings between any of the design ships for the 650-foot channel in the 328-foot bends were not simulated as the pilots considered such a maneuver unsafe. The same scenarios were simulated for the 700-foot HSC widening with the 328-foot bends and were considered to be acceptable. Therefore, a 700-foot-wide channel is carried forward for analysis. Details regarding specific ship simulation can be found in Attachment 5 of this Appendix. An example cross section of the channel template is shown in Figure 4-5.

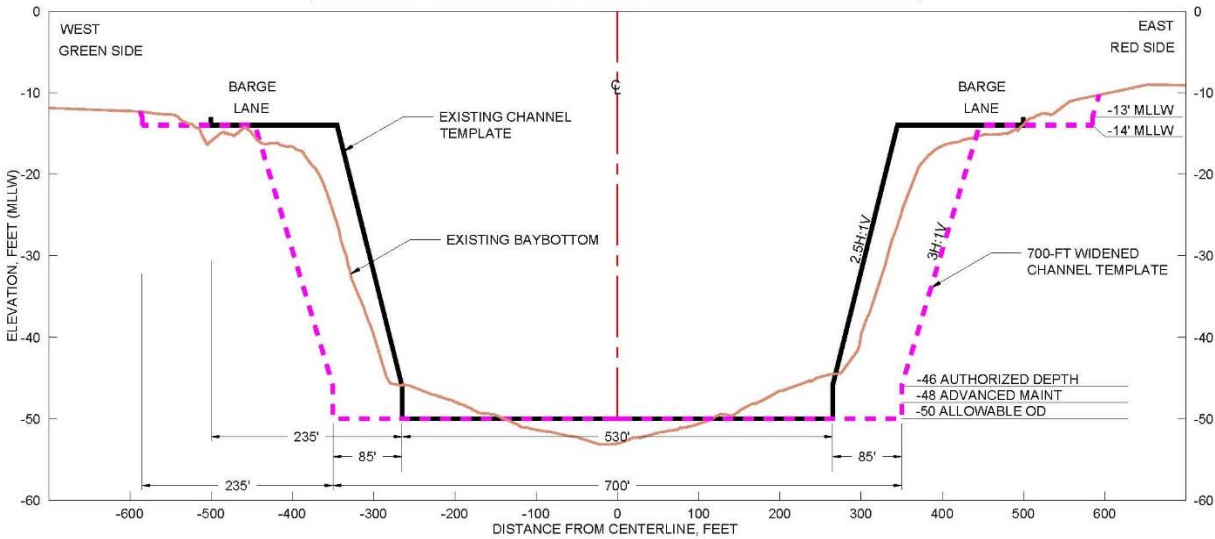

Figure 4-5: Bay Reach Widening 700 Feet from Bolivar Roads to BCC Cross Section

#### 4.2.1.1 Bay Reach Widening 700 Feet from Bolivar Roads to BCC

The bay reach widening measures evaluated for the 700-foot-wide channel are **CW1\_BR-Redfish\_700**, **CW1\_Redfish-BSC\_700**, and **CW1\_BSC-BCC\_700**. These channel widening measures are detailed in Engineering Plate No. 15-23.

If after evaluation of costs, economics, and mitigation requirements the channel could not be widened throughout the entire Bay, the HP suggested that widening the Lower Bay would provide the most benefit since the timing of the inbound ship meeting the outbound ship is easier to determine and manage. However, it is their assertion that the entire HSC artery through the Bay be widened to ensure navigational safety. This section is the longest straight section of the channel and could afford up to 4 vessel meetings assuming 2.5 mile spacing. To evaluate the potential for widening only the lower bay reach, measure CW1\_BR-Redfish\_700 was modified to transition from the bend easing at Station 78+844 to the existing 530-foot HSC at Station 74+119.99 as shown in Figure 4-6. This measure would not



Figure 4-6: Transition at Station 78+844 from CW1\_BR-Redfish\_700 to existing 530-foot channel



lift any other restrictions inbound or outbound further up the channel. This measure has been identified as the NED. CW1\_BR-Redfish\_700 under the NED plan is detailed in Engineering Plate No. 04-07.

#### **4.2.2 Segment 2**

The entrance of the BSC is near Beacon 76 at approximate HSC Station 25+466 where the two channel centerlines meet. The southern boundary of the BSC has a 4,000-foot radius. The current BSC is 46.5 feet deep and approximately 400 feet wide from the start of the BSC Flare at approximate Station 221+00 to the land cut at 112+00. The remaining channel is 350 feet wide from Station 112+00 to 25+58 and includes a 1,600-foot turning basin at its terminus. The HP have expressed concerns for sufficient room for tug assistance and the ability to efficiently navigate large container and wide tanker vessels through the land cut portions of the channel past moored vessels. Additionally, long vessels tend to “crab” (transit diagonally to their heading direction) from the transit between the HSC and the BSC land cut due to wind conditions. This can lead to channel restrictions.

The current forecasted range of container vessel sizes expected to frequently call at PHA range from 1,100 feet LOA x 158 feet in beam to 1,200 feet LOA by 140-foot beam. Additionally, tanker forecasted sizes are 935 feet LOA x 164-foot beam and 750 feet LOA x 138-foot beam. HP requested consideration of additional widening, ranging from 50 to 168 feet at the BSC.

Due to the container terminal berths to the south, widening of the channel to the south is not an option inside the land cut. Therefore, all channel widening considered is to the north. On the north side of the land cut a shore protection rock revetment would have to be removed and replaced for any additional widening scenario. It should be noted that intermittent wetlands are located between the rock revetment and the residential road that will require assessment and mitigation. Conversion of shallow water habitat to deep-water habitat will also need to be considered. Additionally, several pipelines are in the buffer zone between the existing channel top of slope and the adjacent road and residential neighborhood. Widening beyond 100-125 feet may require the relocation of these pipelines and is considered cost prohibitive. Therefore, this was considered as a constraint to the widening of the BSC. A sheet pile bulkhead would be required to protect and secure the north shoreline as discussed in Section 4.6 of this Appendix. From approximate Station 55+00 to 25+58, additional landside development has occurred, and is occurring, to include the San Jacinto Community College, LBC Tank Terminals, and Crosby Tug. The PHA currently has a development easement extending approximately 230 feet from the improved channel toe along the north side of the channel for future development. Any additional widening will require improvements and replacements to the current ATON systems for the BSC and it is assumed that these improvements will constitute the best ATONs assessment. Utilizing the EM design parameters, the range of possible channel widening is shown in Table 4-4. The BSC could be considered a hybrid channel between trench and canal types. The north side slope extends to

daylight like that of a canal type channel. On the south side however, the toe ends at the start of the berthing areas, spans the wide berths, before sloping up underneath the docks. This would make the channel more closely resembling a trench type. Both configurations were evaluated with the EM design guidance and the trench type was found to yield a more conservative channel width requirement than the canal type, and was therefore held. Regarding the water current conditions, the BSC is a dead-end channel with little to no riverine inflow and the flow is thus dominated by tidal currents in the Bay. Bay tidal ebb and flood current velocities would max out at approximately 1 feet per second except under extreme circumstances, and in general would predominantly be under 2.5 feet per second, the upper bound of the middle current regime. Therefore, the mid-level current regime was selected for the BSC design criteria.

Table 4-4: BSC Design Widths by Vessel Size

|                                      | Trench Type Channel Cross Section |             |                        |             | Current Regime          |
|--------------------------------------|-----------------------------------|-------------|------------------------|-------------|-------------------------|
|                                      | 158-foot Design Vessel            |             | 140-foot Design Vessel |             | BSC (MID-CURRENT RANGE) |
|                                      | Beam (ft)                         | Description | Beam (ft)              | Description |                         |
| Vessel Beam <sub>design</sub> (ft)   | 158                               | Container   | 140                    | Container   | BSC (MID-CURRENT RANGE) |
| Vessel Beam <sub>traffic</sub> (ft)  | 158                               | Container   | 140                    | Container   |                         |
| <b>One-Way Best ATONS Multiplier</b> | 3.25                              |             | 3.25                   |             |                         |
| <i>Channel width (ft)</i>            | 515                               |             | 455                    |             |                         |
| <b>Two-Way Best ATONS Multiplier</b> | 5.50                              |             | 5.50                   |             |                         |
| <i>Channel width (ft)</i>            | 869                               |             | 770                    |             |                         |
|                                      | Bayport Ship Channel              |             | Bayport Ship Channel   |             |                         |
|                                      | Beam (ft)                         | Description | Beam (ft)              | Description |                         |
| Vessel Beam <sub>design</sub> (ft)   | 158                               | Container   | 140                    | Container   |                         |
| Vessel Beam <sub>traffic</sub> (ft)  | 158                               | Container   | 140                    | Container   |                         |
| <b>One-Way Best ATONS Multiplier</b> | 2.75                              |             | 2.75                   |             |                         |
| <i>Channel width (ft)</i>            | 435                               |             | 385                    |             |                         |
| <b>Two-Way Best ATONS Multiplier</b> | 4.50                              |             | 4.50                   |             |                         |
| <i>Channel width (ft)</i>            | 711                               |             | 630                    |             |                         |

A 455-foot channel measure, **CW2\_BSC\_455**, was developed for the BSC to meet the EM requirements of the 140-foot beam vessel utilizing the best ATON configuration for one-way traffic under a mid-current regime. This same considered width would meet the requirements of a 158-foot beam vessel during periods of low-current conditions. This would require an approximate 50-foot widening from Station 221+00 to 112+00 and approximately 100-foot widening from Station 112+00 to 25+58 as shown in Figure 4-7 and detailed in Engineering Plate No. 8-9 and 24-25. No deepening beyond the currently permitted 46.5-foot channel is being

considered. However, the recent channel deepening and widening will be included in the documents for specific authorization pending the next WRDA legislation if additional improvements are not warranted by this study.

Ship maneuvering simulations of the BSC widening combined with the 4,000-foot BSC flare and 700-foot HSC channel with 328-foot bend easings were conducted. In all cases three tugs of the 3075 type were considered required and wind limits of 15 knots maximum should be observed. The option to widen the BSC within the land cut to 400 feet was found marginally acceptable, however due to the drift angle required with crosswinds, a 455-foot channel width throughout the channel was preferred.

Slope stability of the north shore of the channel with the proposed channel widening improvements and the installation of a bulkhead were evaluated using existing geotechnical and survey data and the minimum factors of safety were met. Results of the slope stability analysis can be found in Attachment 6 of this Appendix.

This measure would require oyster mitigation. Any widening from Station 112+00 to 25+58 will require the removal and relocation of existing rock revetment, have potential impacts to existing pipelines and cause impacts to development between Station 55+00 to 25+58. It is also assumed that the acreage for widening between Station 112+00 to 25+58 may require mitigation for the conversion of shallow water habitat to deep-water habitat and intermittent wetlands located landward of the rock revetment.

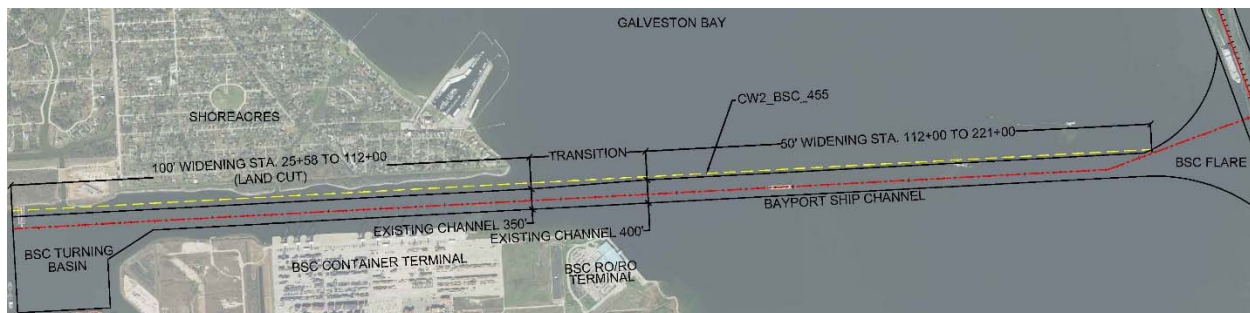

Figure 4-7: CW2\_BSC\_455 - BSC Widening 455 Feet

### 4.2.3 Segment 3

The HP have expressed concerns with the ability to navigate large containers vessels more than 1,100 feet in length into the BCC as well as through the channel past moored vessels. The entrance of the BCC is at Morgan's Point and approximate HSC Station 6+00 where the two channel centerlines meet, just north of the entrance to the Cedar Bayou Navigation Channel. The BCC is a 1.6-mile channel approximately 300-foot wide, at a depth of -46.5 feet MLLW, and includes a turning basin at its terminus. The turning basin is approximately 2,000 x 1,900 feet in dimension. It is essentially land locked on both sides by berthing areas to the south and Spilmans Island PA to the north. The berthing areas are approximately 225 feet wide. The BCC channel is one-way

traffic. Because the channel itself is land locked and short, it is considered to have a low current and thus low current calculations for the channel widening features were considered. The LASH dock between Stations 14+00 and 22+00 as well as the old RO/RO Dock on the southeast side of Dock 1 are currently being removed.

As with the BSC, HP have requested additional widening to allow for more space for tug assistance. The channel is 300 feet wide from approximate Station 68+00 to 33+00. Potential additional channel widths for BCC one-way traffic as described below. As noted above, the low current range values were used to calculate the needed widths of the channel. Due to the presence of the container terminal on the south side of the channel, widening to the south is not an option. Spilmans Island PA is located on the north side of the channel. Its current dikes are at approximately +30 feet MLT. Significant consideration to future slope stability along the south side of Spilmans Island will need to be evaluated along with the impact of long term dredged material placement capacity. ATONS constituting the best assessment would need to be installed; otherwise there is not sufficient area to widen the channel.

Table 4-5: BCC Design Widths by Vessel Size

|   | Trench Type Channel Cross Section |             |                        |             | Current Regime<br>BCC (LOW-CURRENT RANGE) |
|---|-----------------------------------|-------------|------------------------|-------------|---|
|   | 158-foot Design Vessel            |             | 140-foot Design Vessel |             |   |
|   | Beam (ft)                         | Description | Beam (ft)              | Description |   |
| Vessel Beam <sub>design</sub> (ft)      | 158                               | Container   | 140                    | Container   |   |
| Vessel Beam <sub>traffic</sub> (ft)     | 158                               | Container   | 140                    | Container   |   |
| <b>One-Way Best ATONS Multiplier</b>    | 2.75                              |             | 2.75                   |             |   |
| <i>Channel width (ft)</i>               | 435                               |             | 385                    |             |   |
| <b>One-Way Average ATONS Multiplier</b> | 3.50                              |             | 3.50                   |             |   |
| <i>Channel width (ft)</i>               | 553                               |             | 490                    |             |   |

The BCC channel is similar to the BSC in terms of its existing configuration (i.e. docks to south, shoreline to the north, dead-end channel, etc.) Therefore, the same EM design parameter was held for a trench type channel. While it could be also considered a cut off channel, the requirements of the trench channel are more conservative. EM calculations for widening the BCC would require a channel width ranging from 385 to 553 feet wide depending on the ATONS utilized in a low current regime. The EM does not consider the short nature of a channel. Due the range of potential widening, the channel short distance, and the fact that the forecasted vessel sizes for containers vessels are the same as the BSC, a channel width of 455' was selected for evaluation. This measure, **CW3\_BCC\_455**, would require a 155-foot widening from approximate Station 24+75 to 67+11 as shown in Figure 4-8 and detailed in Engineering Plate No. 10 and 26. Input from the HP indicates that the same dimensions for both the BSC and BCC are desired.

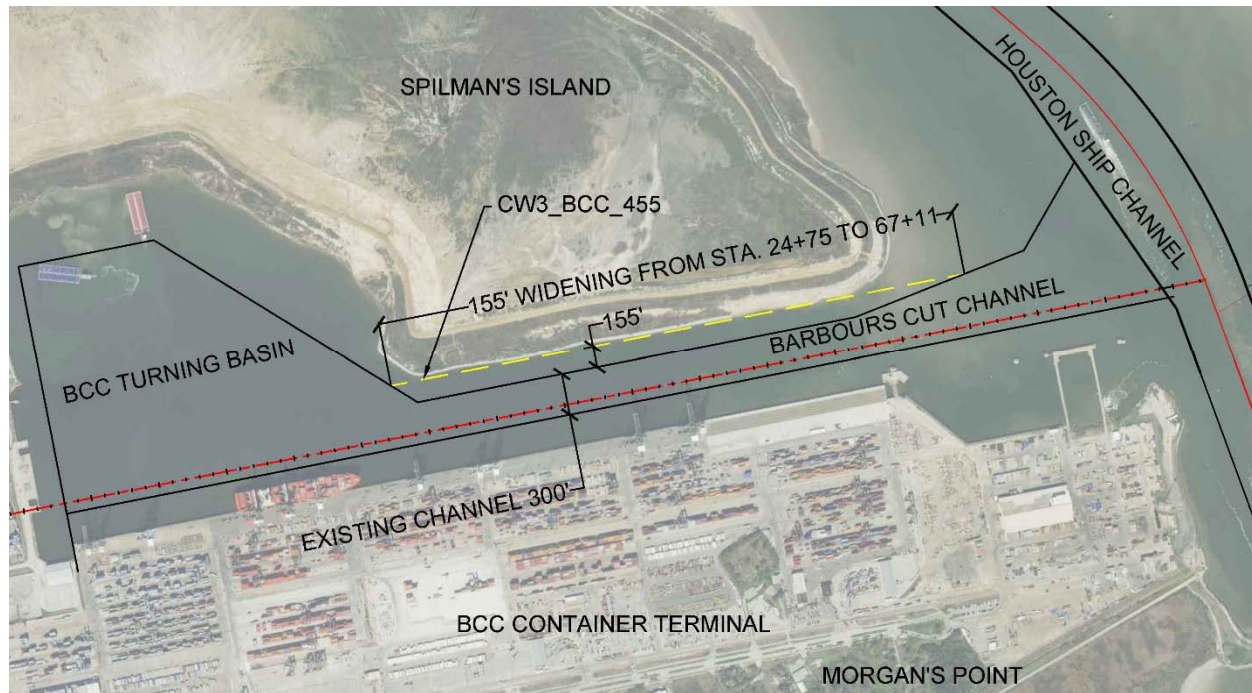

Figure 4-8: CW3\_BCC\_455 - BCC Widening 455 Feet

Ship simulations performed on the 455-foot BCC allowed the successful maneuvering of the design containership turning at the entrance to BCC, transit through the channel past berthed design containerships at the docks, turning in the turning basin, and exiting the BCC. The transit of the design tanker, both inbound and outbound of the BCC was considered acceptable with the 700-foot HSC widening and the easing of the BCC Flare. In all cases three tugs are considered required and wind limits of 15 knots maximum should be observed.

The projected toe of the channel does impact the emergent dikes of Spilmans Island PA. However, a sheet pile bulkhead may still be feasible without relocating any of the existing PA dikes. This increment would require the existing Spilmans Island PA dikes to be shifted to the north towards the interior if a sheet pile type bulkhead is not installed and would require the removal and replacement of the rock revetment shore protection. The dredging of this feature will likely need to be through mechanical dredging rather than the area standard practice of hydraulic dredging to allow for the installation of sheet pile prior to dredging and to reduce the potential for damage to the sheet pile. This will also affect long term maintenance costs. This increment would require exploration and potential removal of some of the historic mooring piles. Ship simulation will be utilized to determine the optimal width of the channel and slope stability analysis will be required along Spilmans Island PA in PED.

Slope stability of the north shore of the channel with the proposed channel widening improvements and the installation of a bulkhead were evaluated using existing geotechnical and survey data and

the minimum factors of safety were met. Results of the slope stability analysis can be found in Attachment 5 of this Appendix.

#### **4.2.4 Segment 4**

The measure developed for Segment 4 considers deepening and widening approximately 8 miles of channel to alleviate current traffic restrictions for both draft and beam widths to allow for benefits to be realized for increased Aframax and Suezmax traffic in this region and to improve the current 116-foot beam restriction. Widening is envisioned through varying degrees to the north and south through meandering centerline shifts. Significant investment from multiple private entities is being made to upgrade, expand and/or develop new facilities regardless of improvements. This section of channel from approximate Station 684+00 to 850+00 is currently 300 feet wide at a depth of -41.5 feet MLLW and is predominantly bounded on both sides by petroleum and chemical industries. Measure, **CW4\_BB-GB\_530**, would widen the channel up to 530 feet from Boggy Bayou to Greens Bayou (Station 684+00 to 833+00) along the centerline and deepen to a depth of -46.5 feet MLLW as shown in Figure 4-9 and further detailed in Engineering Plate No. 11 and 27.

Since the location falls along a compound curve, its configuration is required to be evaluated through ship simulation. This assumes that the current dock setbacks are sufficient to meet HP guidelines and the projected design vessel at this time but should be reviewed in further analysis. As previously stated, HP require all existing dock facilities to be a minimum of 160 feet from the channel toe and a minimum of 225 feet for new facility construction. This measure allows for the petrochemical industry in this stretch of channel to realize the benefits from the downstream 46.5-foot project and would extend the widening up to 530 feet.

Ship simulation of the 530-foot channel from Boggy Bayou to Greens Bayou found it provided successful operations of Aframax and Suezmax vessels, two-way traffic of loaded vessels with a maximum combined ship beam of 246 feet, and the meeting of loaded Aframax and Panamax ships. The meeting of loaded Suezmax with Panamax vessels was problematic, however with further evaluation and training it could be possible. Discussions with the existing and planned LSFs is included in Section 5.3 of this Appendix.



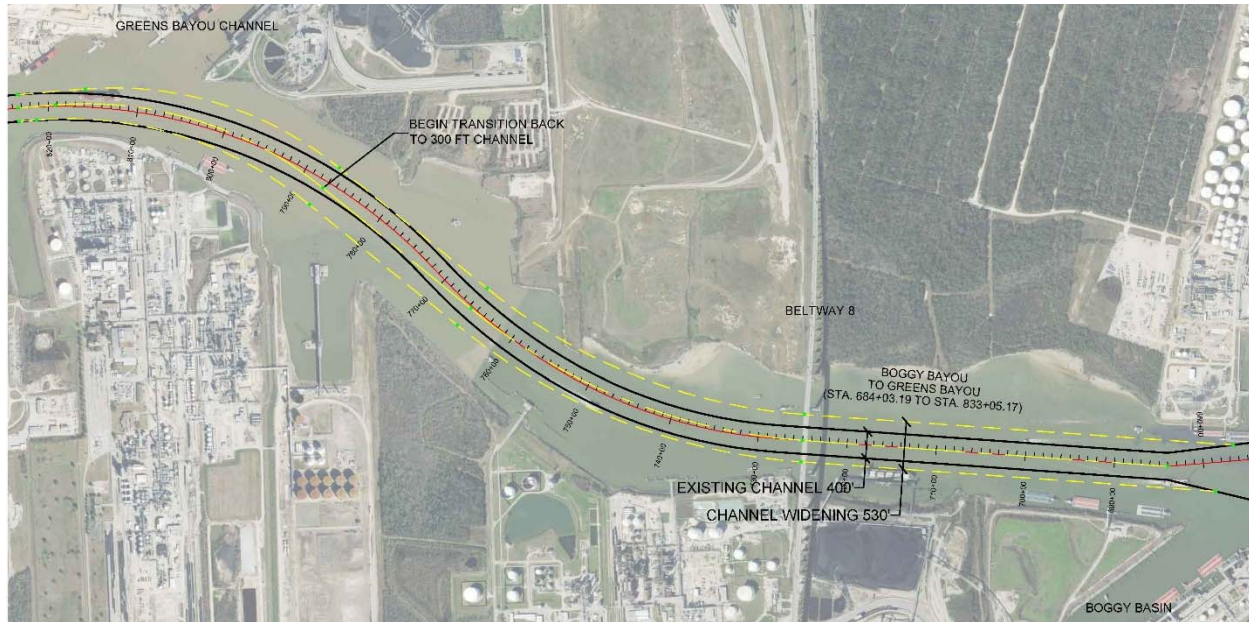

Figure 4-9: CW4\_BB-GB\_530 – Boggy Bayou to Greens Bayou Widening 530 Feet

### 4.3 Channel Deepening

Three measures were developed within Segments 4, 5 and 6 of the HSC that are currently at depths less than -46.5 feet MLLW.

#### 4.3.1 Segment 4

The current depth of the HSC from Boggy Bayou to Sims Bayou is -41.5 feet MLLW. However, at the Washburn Tunnel crossing, the channel depth is maintained at -38.5 feet MLLW, with 2 feet AM, and 1-foot allowable overdepth (AO). Any improvements in this area would have to avoid impacts to the Washburn Tunnel at Station 974+07, a nationally registered historic place. Measure CD4\_Whole proposes to deepen Segment 4 by approximately 5 feet between Boggy Bayou at Station 684+03 to the Hunting Turning Basin at Station 930+00 as detailed in Engineering Plate No. 11-12 and 27-28. This allows for the petrochemical industry in this stretch of channel to realize the benefits from the 46.5-foot project but would not lift current channel vessel beam restrictions. USACE Galveston District Surveys indicate that depths of this segment are already more than -41.5 feet MLLW. The majority of the facilities in this section are currently upgrading, constructing or permitted to upgrade or construct their facilities regardless of these channel improvements. The PHA met with many of the facilities to discuss channel improvements and acquire where possible CADD files and permit drawings of the proposed expansions. Based on the needs of the facilities, and existing pipeline locations, it is recommended that the deepening be stopped after Hunting Turning Basin at Station 930+00.

### 4.3.2 Segment 5

The HSC from Sims Bayou to the I-610 Bridge has an authorized depth of -37.5 feet MLLW. Measure **CD5\_Whole** would deepen this section of channel by approximately 4 feet between Station 1110+77.54 to 1160+62.20 as shown in Engineering Plate No. 13 and 29. This measure would be subject to the same concerns regarding pipelines and dock facilities as CD4\_Whole. No LSF improvements are currently considered in this analysis.

### 4.3.3 Segment 6

The HSC from the I-610 Bridge through the Main Turning Basin has an authorized depth of -37.5 feet MLLW. Measure **CD6\_Whole** would deepen the section of channel by approximately 4 feet from Station 1160+62.20 to 30+95.06 at the Main Turning Basin as shown in Engineering Plate No. 14 and 30. This measure would be subject to similar concerns regarding pipelines and dock facilities as deepening measures in Segments 4 and 5. Deepening of City Dock 16 was the only LSF improvement currently considered in this analysis.

## 4.4 Turning Basins

Turning basins are an integral part of shipping channels, and are required where maneuverability of ship traffic between locations cannot be performed under ship power alone, and requires stopping and tug assisted turning. This situation occurs frequently in the HSC at intersections between channels and at docking facilities.

### 4.4.1 Segment 3

The HP have requested the ability to completely turn a vessel at the entrance to the BCC to back larger container vessels into Docks 1 or 2. This would reduce issues with passage of moored vessels further down the narrow channel by allowing them to turn around at the entrance and immediately dock at the facility. Options were considered for increasing the existing flare on the north side as well as creating a flare on the south side. A combination bend easing/turning basin was developed for the BCC, to facilitate ingress between the channel and the HSC. This measure, **BETB3\_BCCFlare\_1800NS**, considers easing the flare on the north side of the BCC entrance and creating a flare to the south as shown in Figure 4-3 and previously discussed in Section 4.1.3. Refer to Engineering Plate No. 10 and 26. This measure serves a dual purpose; to allow sufficient turning radius for vessel ingress and egress, and to allow vessel turning and backing access to Berths 1 and 2 rather than passing moored vessels in this constrained channel.



#### 4.4.2 Segment 4

The existing turning basin at Hunting Bayou was evaluated to accommodate turning of bulk carriers with a 750-foot LOA, the design vessel in this reach. In accordance with EM 1110-2-1613 and assuming a 0.5 to 1.5 knot current regime, measure **TB4\_Hunting** has a 1,125-foot diameter turning basin. Assuming a less than 0.5 knot current regime, a 900-foot diameter turning circle is also shown for additional reference in Figure 4-10. Evaluation of the existing 900-foot diameter turning basin indicates it

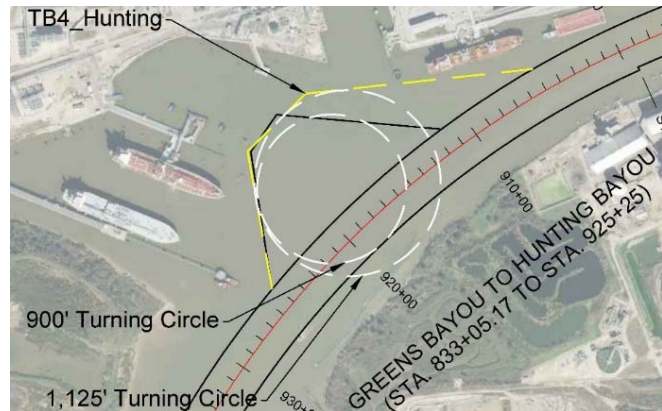

Figure 4-10: TB4\_Hunting - Segment 4 Turning Basin at Hunting Bayou

is currently of sufficient size and does not need further modification, however it will be deepened as part of CD4\_Whole that will deepen this portion of the channel from the -41.5 feet MLLW to -46.5' MLLW

#### 4.4.3 Segment 6

The Brady Island Turning Basin at Station 1195+00 needs to be expanded to accommodate turning of bulk carriers, the design vessel in this reach. Measure **TB6\_Brady\_900**, as shown in Figure 4-11 has a 900-foot diameter turning basin. Ship simulations for an enlarged Brady Island Turning Basin had successful turning maneuvers of Panamax vessels with the assistance of tugs while Panamax vessels were berthed at Wharfs 26-28 and a bunkering barge alongside the ship at Wharf 27. This measure will require the installation of a bulkhead as discussed in Section 4.6 and detailed in Engineering Plate No. 14 and 30.

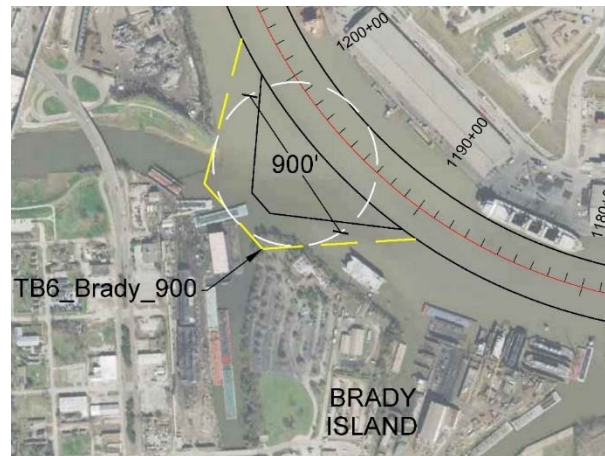

Figure 4-11: TB6\_Brady - Segment 6 Brady Island Turning Basin

#### 4.4.4 BSC Flare Sedimentation Attenuation Feature

The BSC Flare, located at the intersection of the HSC and BSC, has an existing high shoaling rate of approximately 788,000 CY per year. This has led to a maintenance dredging requirement of approximately every 9-12 months. If selected for further consideration, measure BE2\_BSCFlare

would widen the south side of the flare to a 5,375-foot radius. While providing navigational benefits, this measure would potentially increase the flare shoaling by an additional 308,000 CY per year and exacerbate maintenance dredging requirements.

Because of this, sedimentation attenuation feature options were investigated by a Texas A&M professor (Bert Sweetman) while on sabbatical in the USACE SWG office. Two options were developed to reduce the counter-clockwise circulation west of Atkinson Island that is carrying sediment into BSC.

The AdCirc numerical model of currents was applied to HSC by Engineer Research and Design Center (ERDC) (Jennifer McAlpin) which will be used in PED to test these two options.

After completion of the AdCirc model, an option was developed to largely close the circulation into BSC. The purpose of this feature would be to alter the existing sediment pathways currently leading to the flare and redirect them to a location that would decrease the amount of flare shoaling occurring now, while also not worsening channel shoaling elsewhere. This feature has been incorporated into this study conceptually as measure SA2\_BSCFlare. Specific details and requirements of this measure are not known at this time and will be based upon hydrodynamic, salinity, and sediment transport modeling at ERDC during PED. An estimated location for this measure has been sited on the northwest side of the intersection of the BSC and HSC as shown in Engineering Plate No. 31. It would be constructed running along the north toe of the BSC, angle northward at the intersection, and then proceed north running parallel to the west toe of the HSC. The length of the measure is currently estimated to be approximately 9,400 linear feet. Both the length and/or overall configuration could change significantly following the completion of the ERDC study.

This measure is being assumed as a hardened structure at this time, consisting of an armored earthen dike. The dike would be constructed using hydraulically placed new work dredge materials, excavated as part of adjacent channel widening features. The dike would be armored with rip-rap quarry stone similar to adjacent shore protection features along the west side of Atkinson Island. Analysis of this feature is provided in Attachment 9.

Figure 4-12 shows a conceptual design cross-section of a dike of construction type typical to this region. This section was assumed for the length of the measure for cost estimation purposes.

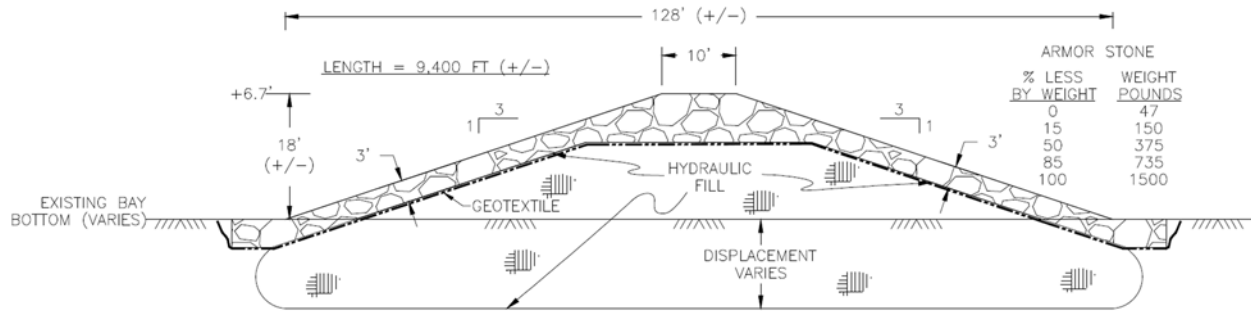

Figure 4-12: BSC Flare Sedimentation Attenuation Feature

Thus three options have been put forth as this feature (two by A&M and the third long straight option described in the preceding three paragraphs). Which of the options might be chosen is expected to be determined by a separate benefit/cost analysis comparing attenuation (prevention) and dredging (reaction).

## 4.5 Sheet piling

Measures requiring sheet piling are those where dredged side slopes (3H:1V) would potentially impact shore side constraints (existing infrastructure, PAs, development, wetlands etc.), making it necessary to provide a stabilizing structure. Sheet piling was assumed to be required where these conditions potentially exist.

The conceptual design for the sheet pile walls was based on similar designs that provided containment to -45 feet. Costs for sheet pile walls were extracted which included a combination of interlocking H-piles (king piles) and intermediate Type Z sheets.

The combined wall system consists of 1) the king pile, 2) intermediary sheet piles, and 3) connectors or tie-rods as shown in Figure 4-13. The design uses a tie-rod welded to or interlocked with the king pile to connect the king pile to the sheet pile, with each tie-rod secured to a sheet pile deadman. Horizontal bracing or walers are also incorporated for horizontal load transfer from the anchored sheet pile to the tie-rods. The conceptual design assumes that current soil conditions are adequate for sheet pile stability and that no backfilling would be required. No platforms or approach slabs are assumed in the design since the purpose of this structure is to retain soil and provide protection from ship wakes, but not for servicing vessels or barges. Sheet pile was not considered as its own measure but is included in the costs of applicable measures. Sheet piling will be required along the north shore of the BSC from Station 35+00 to 43+50 (Engineering Plate No. 08), along the shoreline of Morgans Point at the intersection of the HSC and BCC Flare at approximate HSC Station 0+000 to 0+400 (Engineering Plate No. 10), the north side of the BCC along Spilmans Island from Station 30+00 to 67+00 (Engineering Plate No. 10), and at the Brady Island Turning Basin (Engineering Plate No. 14).

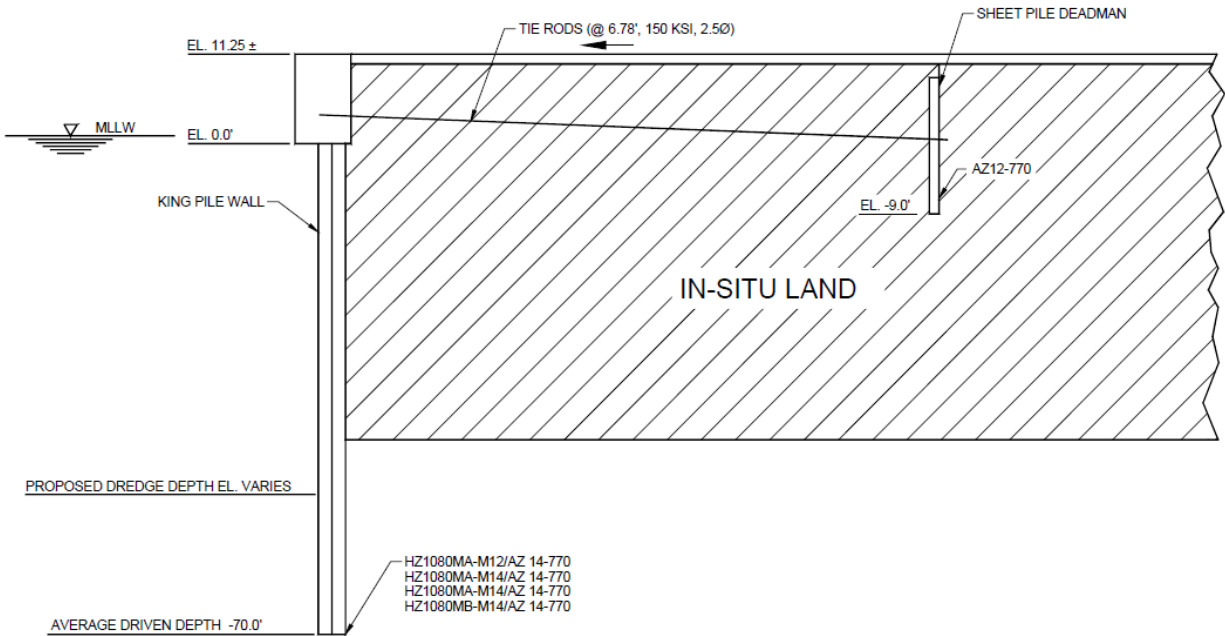

Figure 4-13: Typical Sheet Pile Section

#### 4.6 Aids to Navigation

The relocation or addition of ATONs will be required to delineate the limits of the widened channel(s). Coordination with the United States Coast Guard (USCG) has been performed to evaluate the potential impacts to existing ATONs. In general, ATONs along the HSC between Bolivar Roads to Morgans Point are positioned at the outside toe of the existing barge lanes. These will all require relocation to the outside toe of the relocated barge lanes. In Segment 2, ATONs lying along widened areas will require relocation to maintain required offsets. Additionally, one junction light and one outer range front light will need to be moved. The remaining area impacted lies in Segment 4, at the area of proposed channel widening between Boggy Bayou to Greens Bayou. This area of the channel is proposed to be improved by widening the existing channel up to 530 feet and reconfiguring of the centerline to create smoother bend transitions. A list of ATONs requiring relocation was provided by USCG and is quantified in Table 4-6 in reference to the considered channel measure.

Table 4-6: ATONs for Relocation

| Segment | Measure             | ATON Qty. |
|---------|---------------------|-----------|
| 1       | CW1_BR-Redfish_700  | 31        |
|         | CW1_Redfish-BSC_700 | 26        |
|         | CW1_BSC-BCC_700     | 14        |
| 2       | CW2 BSC 455         | 6         |
|         | CW2 BSCFlare        | 3         |
| 3       | BETB3 BCCFlare 1800 | 2         |
| 4       | CW4 BB-GB 530       | 4         |
| TOTAL   |                     | 86        |

## 4.7 Typical Dredge Material Use Options

General engineering analysis was used to develop scenarios for the construction of new sites to either contain the new work materials as a result of the construction of the channel modifications and/or to create additional future O&M capacity where feasible. The placement measures for new work were generally sized to hydraulically construct dikes for the measure with the new work in Galveston Bay. There are no new non-Federal facility improvements in Galveston Bay. In Boggy Bayou in-situ earthen dikes were sized on the various PAs to contain the new work. The Boggy Bayou area of the channel is heavily constrained by existing industrial and residential developed property. Therefore, few opportunities for new dredged material placement options are available within reasonable proximity to the channel. A combination of upland confined PAs (UCPA) and BU PAs, their sizes and general engineering considerations are discussed below. The selected UCPA and BU PAs will undergo further geotechnical, surveying, and engineering analysis in PED and their sizes will be adjusted accordingly.

### 4.7.1 Beneficial Use

The Federal Government has placed considerable emphasis on using dredged material in a beneficial manner. Statutes such as the Water Resources Development Acts of 1992, 1996, 2000, and 2007 demonstrate that BU has been a Congressional priority. The USACE has emphasized the use of dredged material for BU through such regulations as 33 CFR Part 335, ER 1105-2-100, and ER 1130-2-520 and by Policy Guidance Letter No. 56. ER 1105-2-100 states that “all dredged material management studies include an assessment of potential BUs for environmental purposes including fish and wildlife habitat creation, ecosystem restoration and enhancement and/or hurricane and storm damage reduction” (USACE, 2000, E-69). Opportunities for BU of dredged material exist in the project vicinity. Meetings with the Beneficial Uses Group (BUG), consisting of Federal and state resource agencies (EPA, NMFS, NRCS, USFWS, TCEQ, TGLO, and TPWD) were conducted throughout the development of the Dredge Material Management Plan for the HSC ECIP to discuss potential BU options.

The BU components of the RP are considered general navigation features and the cost sharing is determined by WRDA 86, as amended. The BU components of this plan are considered general navigation features because the BU sites are part of the Federal Standard/Base Plan.

Typically, design of BU projects requires a grain size/compatibility analysis and potentially modeling of sediment transport and fate to be completed for these types of projects. To meet the goals of accelerating the schedule and reducing study costs, this work is scheduled for the PED phase. As a result, the measures are discussed in the Feasibility Report/EIS without detailed analysis, but with a commitment to perform additional analysis during the PED phase and re-coordinate all decisions with resource agencies to ensure environmental acceptability. Final designs, decisions to implement, and final environmental considerations/clearances would take place during the PED phase if significantly altered. Some of the engineering considerations and analyses to be conducted during the PED phase include but are not limited to:

- Grain size analysis and PSDDF consolidation testing of materials to be dredged by reach considered for BU marsh construction to determine the bulking and consolidation characteristics of the materials to be dredged and placed.
- Geotechnical probings and borings to determine foundation characteristics for stability and consolidation to determine construction and maintenance elevations.
- Site specific wind and wave analysis to determine optimal dike heights and shore protection features.
- Intertidal marsh elevation surveys would be conducted on neighboring marshes to the site selection to determine the optimal tidal elevation target range with consideration of RSLC. Surveys and conversions should be NAVD88.
- Natural and artificial reef surveys to determine optimal design elevations, contours, and monitoring strategies.
- Ground truthing of assumptions made for planting marshes and bird islands during the HGNC deepening and widening construction and maintenance

### 4.7.1.1 8-Acre Bird Island

The proposed 8-acre bird island as shown in Figure 4-14 and Figure 4-15 would be located in Lower Bay, east of the HSC as shown in Engineering Plate No. 33. The preliminary design uses the same project elevations used in the design of the existing bird island from the HGNC LRR and FSEIS (USACE, 1995). Estimated neatline quantity of material for construction is 546,000 CY. With a retainage rate of 60% the total new work material required is 910,000 CY. The retainage rate considers foundation displacement to -15 feet MLLW.

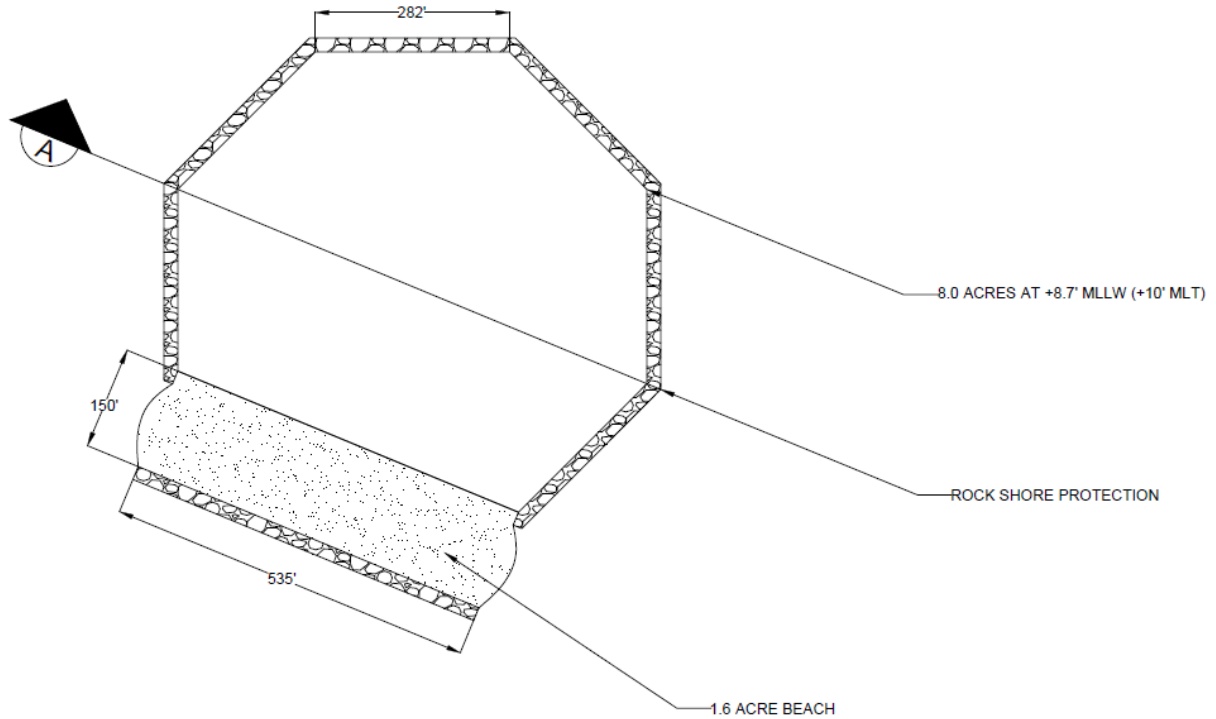

Figure 4-14: 8-Acre Bird Island Plan View

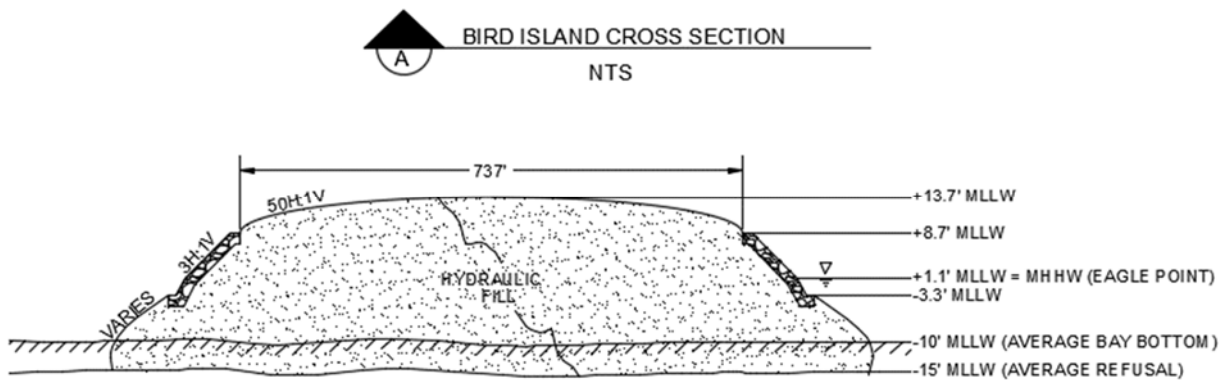

Figure 4-15: 8-Acre Bird Island Cross Section



### 4.7.1.2 Long Bird Island

The 6-acre bird island would be located in Lower Bay, east of the HSC as shown in Engineering Plate No. 31. A dike with rip rap would be constructed along the channel side of the island to minimize wave impacts, and an oyster reef/wave trip along the back side as shown in Figure 4-16 and Figure 4-17 (Engineering Plate No. 34). The distance from the oyster reef/wave trip is approximate and will be defined post wind/wave calculations dependent on the final project location.

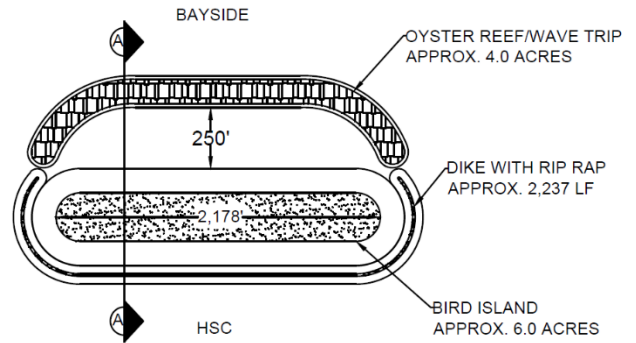

Figure 4-16: Long Bird Island Plan View

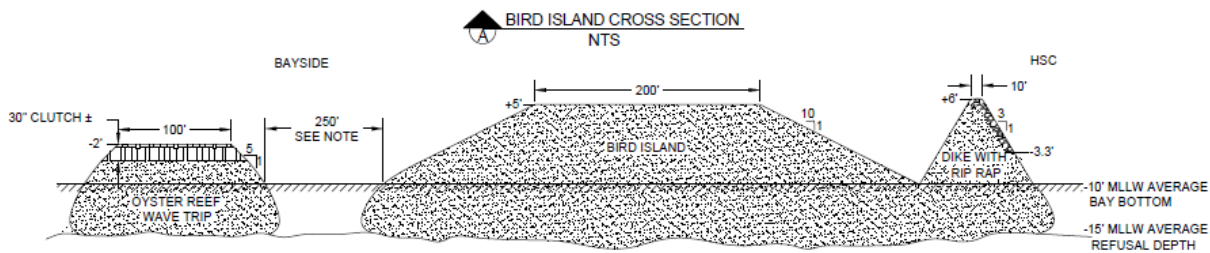

Figure 4-17: Long Bird Island Cross Section

Estimated neatline quantity of material for construction is 703,000 CY. With a retainage rate of 60% the total new work material required is 1,172,000 CY. The retainage rate considers foundation displacement to -15 feet MLLW. The intent of this bird island is for nesting habitat for skimmers. Natural habitat for the target species typically is barren ground devoid of vegetation and consisting of shell hash. During PED, habitat should be evaluated and coordinated with the resource agencies to determine if barren ground is sufficient or if placement of a shell substrate cap over all or some of the island is feasible and within budget. As shell hash is not typically readily available, a crushed limestone product known as DF blend can potentially be considered for and placement as a cap.

The DF blend is a crushed limestone product used in road base applications that generally matches the gradation of existing shell hash common in the region. While similar in gradation, the general shape of the graded rock is more rounded than that of shell hash. Despite this difference, it has been used in at least one recent regional project that has exhibited immediate successes (Figure 4-18). Current



Figure 4-18: Oyster Catcher nesting one day after completion of the Dickinson Bay Island Ground Nesting Habitat Enhancement Project (Source: Galveston Bay Foundation)

design and cost estimates for bird islands do not include these materials, however as part of a final design they would be evaluated with ultimate selection based on proven application, as well as prudent engineering design and judgment.

### 4.7.1.3 Bird Island Marsh

This BU area would be located in Trinity Bay along the Mid Bay Reach of the HSC as shown in Engineering Plate No. 31. The preliminary design includes three 2-acre bird islands positioned in a triangle. The islands are connected by an armored dike approximately 5,224-ft in length. The BUG members requested the dikes be bowed outward to create a round dike alignment versus a straight line between islands. An oyster reef/wave trip will be created outside the bird islands not protected by the dike structure to provide wading habitat for nesting and foraging birds.

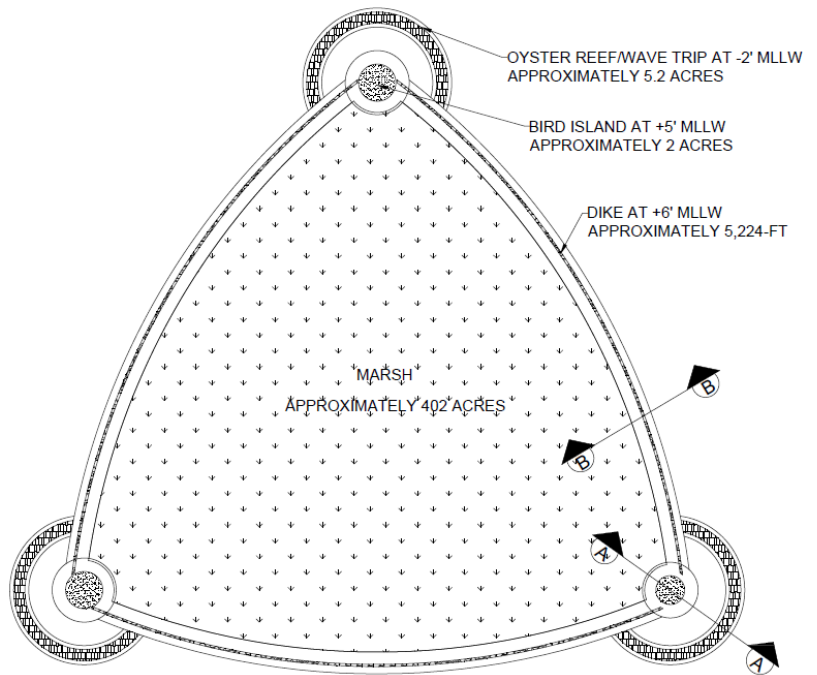

Figure 4-20: Bird Island Marsh Plan View

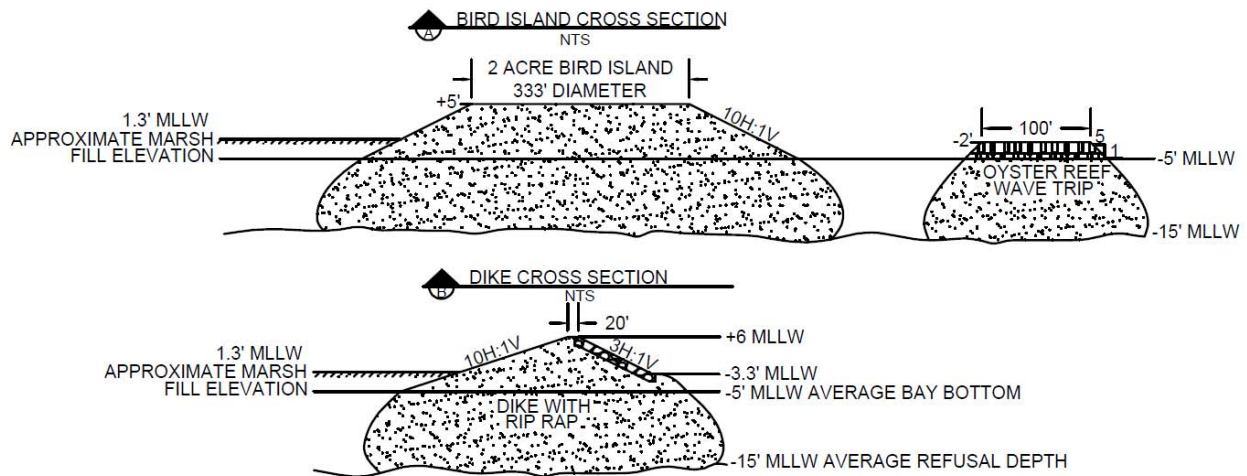

Figure 4-19: Bird Island Marsh Cross Section

Estimated neatline quantity of material for construction is 2.7 MCY CY. With a retainage rate of 60% the total new work material required is 4.5 MCY. The retainage rate considers foundation displacement to -15 feet MLLW. This BU area will create a 402-acre marsh with a neatline capacity of fill to +1.3 feet MLLW of 7.3 MCY, which is 11.2 MCY after 65% consolidation.

Future fill capacity due to RSLC is 2.5 MCY. Should more material become available, the bird island sizes will be increased to improve the upland habitat being provided to avian populations, up to 6 acres, and the marsh dikes lengths or widths could be increased. Should size reduction need to occur, the size of the inner marsh will be decreased, and bird island sizes will remain constant. Site detailed in Engineering Plate No. 32.

#### 4.7.1.4 M11 & M12

Two new marsh cells were evaluated that would expand upon the existing BU sites at Atkinson Island as shown in Figure 4-21. M11 would be created with an approximate 1.8-mile dike between M7/8/9 and M10 and will be unarmored. A typical perimeter dike cross section is shown in Figure 4-22. Estimated neatline quantity of material for construction is 1.7 MCY. With a retainage rate of 60% the total new work material required is 2.8 MCY. The BU area will create approximately 445-acres of marsh with a neatline capacity of fill to +1.3 feet MLLW of 4.5 MCY, which is 6.9 MCY after 65% consolidation. Future fill capacity due to RSLC is 2.6 MCY (1.7 MCY neatline). The retainage rate considers foundation displacement to -15 feet MLLW. Access to existing wells will need to be coordinated during PED an may include construction of access pad, and permit renewals should be denied.



Figure 4-21: BU sites M11 & M12

M12 is located on the north end of Atkinson Island and would require an approximate 1.5-mile dike. Estimated neatline quantity of material for construction is 1.4 MCY. With a retainage rate of 60% the total new work material required is 2.3 MCY. The BU area will create approximately 273-acres of marsh with a neatline capacity of fill to +1.3 feet MLLW of 2.8 MCY, which is 4.3 MCY after 65% consolidation. Future fill capacity due to RSLC is 1.7 MCY (1.1 MCY neatline). The retainage rate considers foundation displacement to -15 feet MLLW. An access corridor via an earthen pad or other will need to be considered in coordination with energy interests for well servicing in the future during PED.

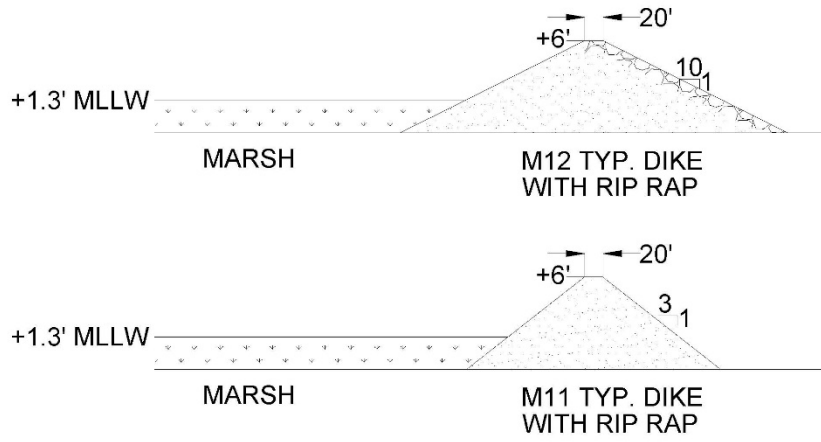

Figure 4-22: Typical perimeter dike cross section for M11 & M12

#### 4.7.1.5 Bay Aquatic Beneficial Use Site

Bay aquatic BU sites (BABUS) located in Galveston Bay are proposed to provide storage for maintenance material volumes that exceed existing confined PA capacities. BABUS are confined aquatic disposal (CAD) cell excavated below existing bay bottom with an emergent dike constructed around the CAD cell using the excavated soils placed hydraulically to create BU or habitat areas. The estimated interior excavation elevation would be -70 feet MLLW and the dike crest elevation would be +6 feet MLLW for the purposes of this study. Actual elevations will be determined during design. The BABUS concept includes establishing submerged, intertidal, and emergent habitat on the dikes, with the interior area of each site raised to create intertidal marsh habitat once filled to capacity. The interior excavation will be performed using hydraulic cutter head dredge with the excavated material used to build the exterior dikes and the resulting habitat. The dikes will have 7H:1V inside side slopes. The exterior side slopes will be compound with 7H:1V from the dike crest down to elevation +3 feet, then 30H:1V side slopes below elevation +3 feet down to bay bottom to provide more habitat area and protection against erosion from the bay wave and current environment.

The BABUS would be constructed in Galveston Bay, south of Atkinson Island, north of Midbay PA, and east of the HSC as shown in Figure 4-23, with the intent to avoid oyster impacts and impacts to existing pipelines. Design and placement of the BABUS sites will take into consideration minimization of bay bottom area impacts by overlapping the outside toes of adjacent sites.

The BABUS sites would be utilized to provide storage for OM dredged material once the existing confined PAs have reached capacity. They would also be able to accept new work from expansion of either Federal channels or non-Federal facilities. The OM dredged material would be placed in the BABUS using bottom-dump scows and/or hopper dredges that would access the interior of the sites using the existing Five Mile Cut (widened and deepened as required) and then through access channels excavated into the Bay bottom and extending through gaps in the exterior dikes. Once the BABUS fill elevation prevents floatation inside each site, the exterior dike would be closed, and the interior would be filled to final marsh elevation using OM material dredged and hydraulically pumped into the sites. Estimated OM dredged material capacities

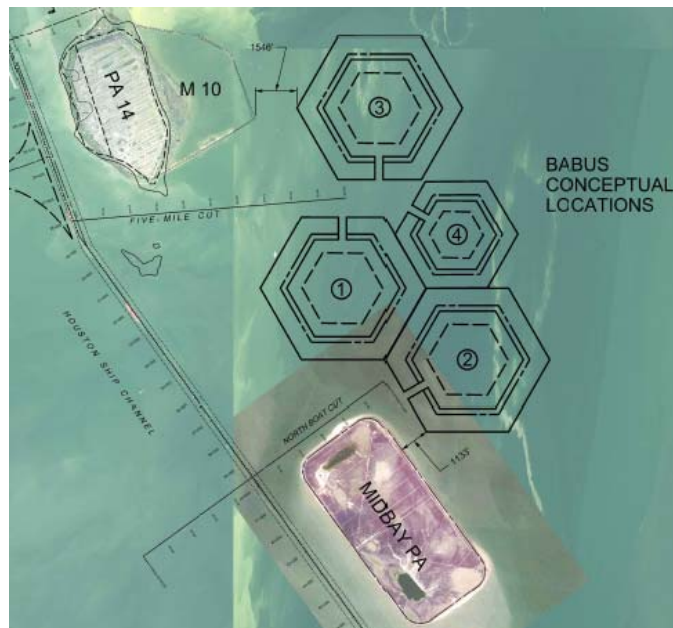

Figure 4-23: Conceptual layout of BABUS cells

for the BABUS sites are 29 MCY and 15 MCY for the 325-acre and 200-acre sites, respectively. For the FWOP DMMP, an estimated four (three 325-acre and one 200-acre) BABUS sites would be required to provide capacity for O&M (Federal and non-Federal) material dredged over the 50-year analysis period.

The BUG has requested that a longer flatter slope of approximately 50:1 be considered to provide for a greater footprint of fringe marsh and higher uplift associated with the project design and allow for a long-term approach to RSLs. Additionally, consideration of additional circulation through channeling of the BABUS dikes should be evaluated in the initial and final designs during PED. The conceptual design is provided in Figure 4-24.

Exact locations of the dikes will be adjusted during PED to avoid placing dikes on the oyster-mining holes dug in the mid 1900s, which are now filled with anoxic semi-fluid unconsolidated sediments.



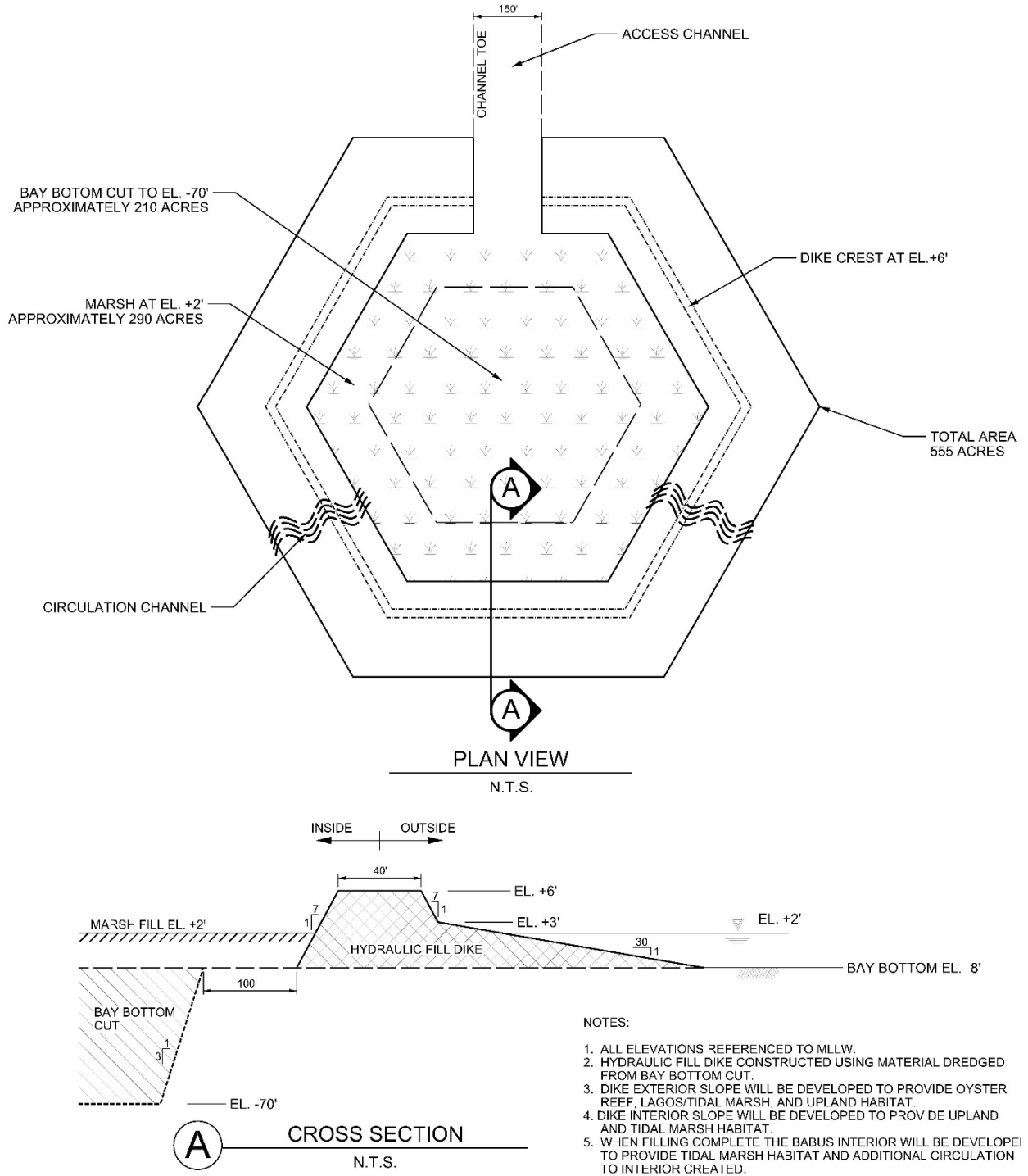

Figure 4-24: Bay Aquatic Beneficial Use Site

#### 4.7.2 Upland Confined Placement Areas

A UCPA, also known as confined disposal facilities (CDF), is an engineered structure for the containment of dredged material. UCPAs are bound by confinement dikes or structures to enclose the PA, thereby isolating the dredged material from its surrounding environment. The material is placed into the UCPA either hydraulically or mechanically. Hydraulically placed dredged material contains a large amount of additional water when it is introduced into the facility, causing it to occupy several times its original volume. To maximize the UCPA capacity, management measures for dewatering the sites must be followed, including ditching, drying, and draining of materials to allow for consolidation and increased capacity. Following these measures allows the dredged material to consolidate to 65-70 percent of its gross volume.

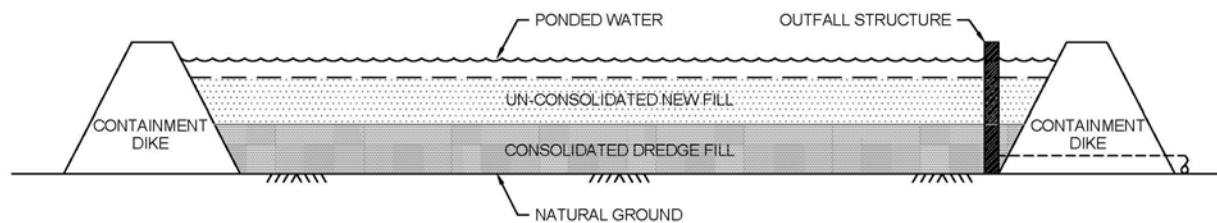

Figure 4-25: Typical Section of Hydraulic Fill at an Existing UCPA

The design of UCPAs shall follow EM 1110-2-5025, *Dredging and Dredged Material Management* (USACE, 2015). Steps to design the UCPAs in more detail during PED will generally include the following steps.

- Hydrographic and topographic surveys of the project areas to develop bay bottom and upland elevation contour data. These surfaces were used during the design of the dredging templates and the dike templates. Hydrographic data is used to estimate material quantities to be dredged.
- Analyze existing geotechnical data, including boring logs and material test results, and evaluate the need for additional investigations
- Geotechnical field investigations including borings and probings at candidate sites to determine the subsurface conditions of the existing foundations. Material testing of samples to include strength tests, sieve analysis, settling tests, Atterberg Limits and consolidation tests. Analysis of material testing results will identify material characteristics needed for the design of the proposed dikes.
- Classification of dredge material and quantity calculations of each material type available within the proposed dredge areas
- Perform slope stability analysis for dike template design



- Calculate material quantities required to construct containment dikes
- Determine corresponding required dredging quantities based upon expected cut/fill ratios
- Wind, tide, and current data and model outputs for the area should be collected and analyzed to evaluate design wave conditions for the design of the shore protection elements, and to consider future sea level change into the design process. Since future sea levels are unknown, dikes will be monitored and added to in a long-term “adaptive” approach.
- Identify project constraints and existing features that must be protected, e.g., gas and oil wells, pipelines, and other utilities.
- Slope stability analysis on existing UCPAs was conducted during the HSCPA and are included in Attachment 7 in this Appendix.

#### 4.7.2.1 Mid Bay Upland Confined Placement Areas

Three UCPAs were evaluated in the Mid Bay reach of the HSC as shown in Figure 4-26, two expansions on the existing Mid Bay PA, and a stand-alone site called Upland Concept No. 1. Preliminary design of each site includes an initial dike construction to +20 feet MLLW with a 20-foot crown width and 3H:1V slopes to average depth of refusal at -15 feet MLLW, and an interior site fill to +18 feet MLLW. To estimate future capacity the dikes will be raised to +40 feet MLLW with material from within the site. Final site fill elevation will be +38 feet MLLW. Material quantities for the construction and continued O&M use of the sites is provided in Table 4-7. The retainage rate considers foundation displacement to -15 feet MLLW.



Figure 4-26: Mid Bay UCPAs

Table 4-7: Mid Bay UCPA Volumes

| Mid Bay Expansion   | Mid Bay Expansion North<br>(292 Acres) | Mid Bay Expansion South<br>(292 Acres) | Upland Concept #1<br>(334 Acres) |
|---|--|--|----------------------------------|
| Construction +20' Dikes (Neatline)  | 1,700,000                              | 1,700,000                              | 2,700,000                        |
| NW Material From Cut  | 2,800,000                              | 2,800,000                              | 4,500,000                        |
| Site Fill To +18' MLLW (Neat Line)  | 10,400,000                             | 10,400,000                             | 19,000,000                       |
| Maint Required From Cut To +18' MLLW  | 16,000,000                             | 16,000,000                             | 29,200,000                       |
| Construction +40' Dikes (Neatline)  | 1,000,000                              | 1,000,000                              | 1,900,000                        |
| Borrow Material From Site   | 1,500,000                              | 1,500,000                              | 2,900,000                        |
| Site Fill To +38' MLLW (Neat Line)  | 10,600,000                             | 10,600,000                             | 19,500,000                       |
| Maint Required From Cut To +38' MLLW  | 16,300,000                             | 16,300,000                             | 30,000,000                       |
| Total NW  | 2,800,000                              | 2,800,000                              | 4,500,000                        |
| Total Maint   | 32,300,000                             | 32,300,000                             | 59,200,000                       |
| Note:<br>1. New Work Dike Construction Volumes Calculated To The Average Depth Of Refusal -15 feet MLLW.<br>2. Maintenance Fill Volumes Calculated To The Average Bay Bottom Of -5 feet MLLW. |  |  |                                  |

#### 4.7.2.2 Bayou Upland Confined Placement Areas

UCPAs were evaluated in the Upper Bayou reach of the HSC for the placement of new work and maintenance materials from Segments 4, 5 & 6 as shown in Figure 4-27. The Beltway 8 (BW-8) and E2 Clinton (E2C) tracts would be two new sites for one-time placement of new work materials from the Federal Channel. After material placement and grading at BW-8, the PHA plans to develop the site. The BW-8 is a former munitions storage facility that includes approximately 50 bunkers and is heavily wooded. The PHA is cleaning and grubbing the site and demolishing the bunkers. The site has been surveyed for unexploded ordnance clearance and has been environmentally cleared by TCEQ. See Section 7.5 for HTRW descriptions. No future plans for E2C are considered at this time. The Rosa Allen Expansion (RAE) would expand upon the existing Rosa Allen PA to create a new cell for O&M maintenance materials in the future.

The Lynchburg tract was not considered for new work placement due to the site's distance of approximately 14 miles from the nearest new work dredging location. Segment 4, hydraulic dredging of the stiff clay new work materials in this area would be cost prohibitive if even possible. The site was additionally removed from screening consideration for maintenance material dredging. Additional increased costs would include expensive initial site construction, laying and maintenance of several miles of pipeline per dredging event, installation and upkeep of permanent culverts, and construction of over two miles of drainage ditching and culverts from the PA outfall. More importantly however, the FWOP condition includes the construction of BABUS PAs. With additional capacity already being provided by these BABUS sites, the development of the Lynchburg site for O&M was not considered further."

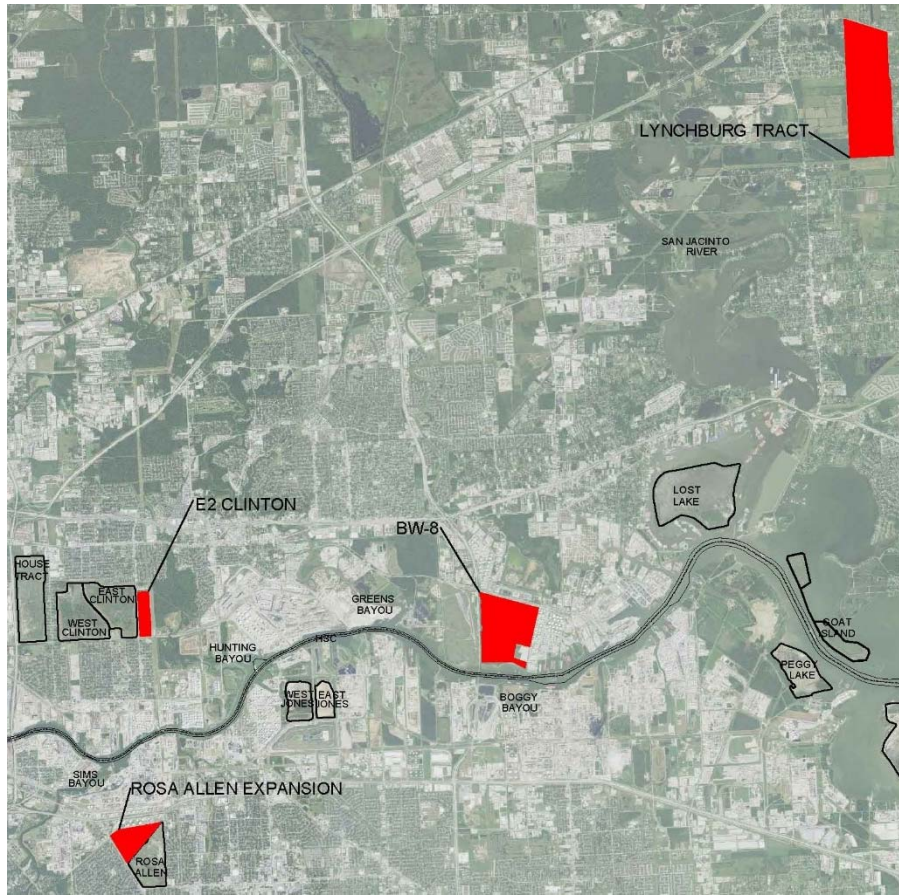

Figure 4-27: New Bayou Upland Confined Placement Areas

A typical dike section was developed to contain the anticipated fill. At BW-8 and E2C, the dike section was designed to contain the proposed new work materials. At RSE, the dike was designed to create an initial dike capable of containing maintenance materials and that future raising events would increase its height. In both cases, the dike initial construction consists of borrowing of interior materials to construct a dike to target elevation. The section would have a 20-foot crown and 3H:1V side slopes on both sides.

The dikes would be constructed mechanically and volumes account for 40% material losses during construction. Table 4-8 provides the measures and quantities relative to each location.

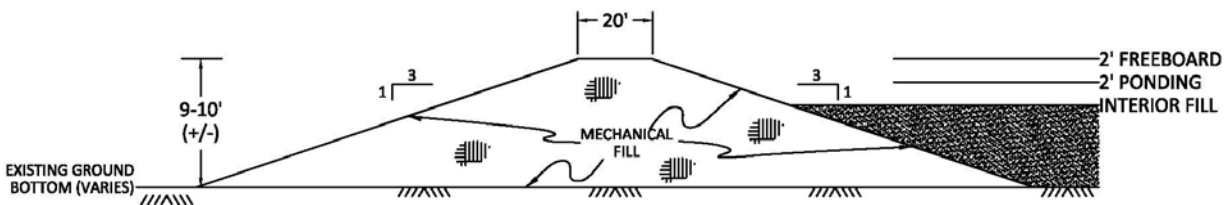

Figure 4-28: Typical Bayou UCPA Initial Dike Section

Following placement of new work materials on BW-8 and E2C, no further work would be done at these sites. Following the initial dike raising at RSE, the area could begin receiving maintenance materials. Dikes would be raised through normal construction general means during future years operations and maintenance. An ultimate dike elevation of 55 feet was assumed feasible for RSE, matching the USACE stability analyses for the adjacent Rosa Allen PA as part of the HSC Preliminary Assessment. Adjacent ground elevation was approximated at +26 feet.

Table 4-8: Bayou Confined UCPA Quantities

| Placement Area  | Acreage (AC) | Perimeter (FT) | Dike Ht. (FT) | Dike Qty. (CY) | Site Cap. (CY) | Ult. Cap. (CY) |
|---|--------------|----------------|---------------|----------------|----------------|----------------|
| BW-8  | 355          | 16,800         | 9.1           | 446,000        | 2,920,000*     | NA             |
| E2C   | 70           | 8,900          | 9.3           | 244,000        | 562,000*       | NA             |
| RAE   | 138          | 11,300         | 10.0**        | 349,000**      | 1,113,200**    | 10,760,000     |
| Notes:<br>*BW-8 and E2C represent quantities and capacities to contain new work fill only.<br>**RAE quantities representing initial dike raising quantity to make site ready to receive maintenance materials, and initial maintenance material capacity. Future dike raising events provide increased capacity to achieve estimated ultimate capacity. |              |                |               |                |                |                |

## 5 QUANTITY COMPUTATIONS

### 5.1 New Work Quantities

Volumes were calculated using USACE single beam survey data and supplemented with hydrographic surveys from the JV and NOAA where available. Survey data acquisition methods and dates of collection varied and can only be considered as indicating the general condition existing at that time. Refer to Table 5-1 for a summary of survey sources and dates used to calculate volumes. All survey data that was previously collected in MLT was converted to MLLW.

Table 5-1: Survey Data used to Calculate Material Quantity

| Channel Section      | Survey      | Source | Date                              | Datum |
|----------------------|-------------|--------|-----------------------------------|-------|
| Lower Bay            | Single beam | USACE  | 3/2/2016 & 3/28-30/2016           | MLLW  |
|                      | Single beam | NOAA   | 1995-2013                         | MLLW  |
| Mid Bay              | Single beam | USACE  | 5/3/2016                          | MLLW  |
|                      | Single beam | NOAA   | 1996                              | MLLW  |
|                      | Single beam | USACE  | 06/01/2018                        | MLLW  |
| Upper Bay            | Single beam | USACE  | 5/6/2016                          | MLLW  |
|                      | Single beam | NOAA   | 1995-1996                         | MLLW  |
| Bayport Ship Channel | Multibeam   | JV     | 10/18-20/2016 & 7/18/2016         | MLT   |
|                      | Single beam | JV     | 7/20/2016                         | MLT   |
|                      | Single beam | USACE  | 04/30/2018                        | MLLW  |
| Barbours Cut Channel | Single beam | USACE  | 4/1/2016 & 5/5/2016               | MLLW  |
|                      | Single beam | JV     | 06/12/2014 & 09/17/2015           | MLT   |
|                      | Multibeam   | JV     | 09/14-15/2015                     | MLT   |
| Bayou                | Single beam | USACE  | 04/15/2016 & 05/2-11/2016         | MLLW  |
|                      | Single beam | JV     | 07/27/2018 (Sta. 676+53 – 825+00) | MLLW  |

Where no survey data was available, outward most points in the dataset were extended out to cover the limits of the dredging prisms. It should be noted that the provided volumes should be considered preliminary and approximate as true bottom conditions may differ from that used. The USACE typically only performs hydrographic surveys between the channel toes and does not cover the extents of the channel slopes. During PED the extents of the proposed channel toes along with a 500-foot buffer shall be surveyed to refine the quantities estimated and monitored post construction to capture channel sloughing for shoaling analysis. No topographical data was available in locations where dredging prisms extended above existing natural ground as shown from aerial photography. Additional survey data is required to determine full material volumes to be removed in these locations.

Volumes were calculated using Trimble Terramodel 10.61 by comparing survey data to the proposed measure templates. Mooring facilities, turning basins, and new spur channels were



calculated by modeling the proposed measure and calculating DTM volumes through surface-to-modeled-surface comparisons. Proposed measures for modifications to existing channels were calculated by creating road jobs with design templates and computing average-end-area volumes for affected reaches.

Existing maintenance materials (materials existing within current authorized channel limits as shown in Figure 5-1) were excluded because only the new work material totals could be considered specific to the measures being evaluated. Maintenance materials would fall under current Federal O&M responsibilities and therefore not be applicable to alternatives screening.

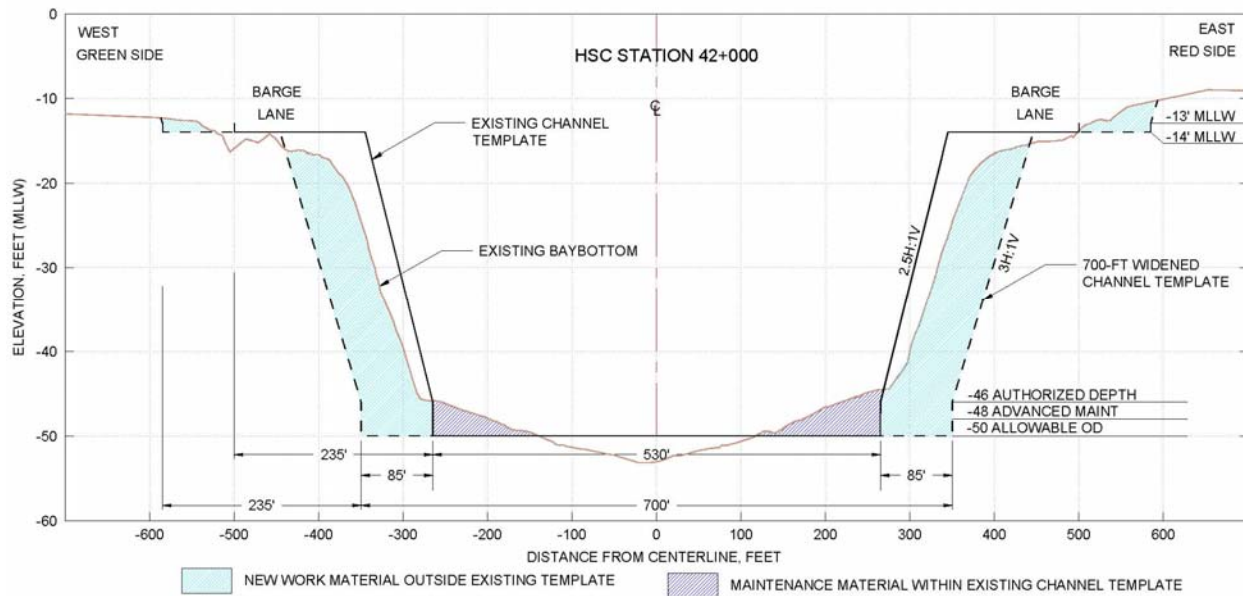

Figure 5-1: 700-FT Channel Widening Typical Template

Final design templates will be evaluated in PED based on geotechnical properties in accordance with Section 3.3.

### 5.1.1 Segment 1: Bay Reach

The HSC from Bolivar Roads to Morgans Point (BCC) is 530 feet wide. The remainder of Segment 1 from Morgans Point up through Carpenters Bayou varies from 530 to 600 feet wide and additionally along channel curves. The currently authorized depths for this segment of the HSC are provided in Table 5-2. The existing channel template was created with 2.5H:1V slope beginning at the authorized depth with a box cut down to allowable overdepth (AO). The Bay Reach is maintained with two feet of advanced maintenance (AM) and two feet of AO. All new work templates have 3H:1V slopes. Widening volumes in the HSC Bay sections from Bolivar Roads to BCC include the offset of the barge lanes 500 feet from the channel centerline as shown in Figure 5-1. All new work quantities calculated for the Segment 1 measures are provided in Table 5-3. Quantities for widening measures are incremental to (i.e. non-inclusive of) the bend measures provided for the existing channel width and are rounded to the nearest thousandth.

Table 5-2: Currently Authorized Depths for Segment 1

| Channel Section                 | Start Station | End Station | Authorized Depth (MLLW) | Advanced Maintenance (MLLW) | Allowable Overdepth (MLLW) |
|---------------------------------|---------------|-------------|-------------------------|-----------------------------|----------------------------|
| Bolivar Roads to Redfish        | 138+369.011   | 78+844.001  | 46                      | 48                          | 50                         |
| Redfish to BSC                  | 78+844.001    | 28+605.055  | 46                      | 48                          | 50                         |
| BSC to BCC                      | 28+605.055    | -0+003.944  | 46.5                    | 48.5                        | 50.5                       |
| BCC to Exxon                    | 0+05          | 295+00      | 46.5                    | 50.5                        | 51.5                       |
|                                 | 280+05        | 295+00      | 46.5                    | 48.5                        | 49.5                       |
| Exxon to Carpenters Bayou       | 295+00        | 520+00      | 46.5                    | 48.5                        | 49.5                       |
| Carpenters Bayou to Boggy Bayou | 520+00        | 684+03.19   | 46.5                    | 48.5                        | 49.5                       |

Table 5-3: New Work Quantities for Segment 1

| Measure  | Description  | New Work Quantity (CY)  |
|--|--|---|
| <b>Bolivar Roads to Redfish Station 138+369.011 - 78+844.001</b> |  |   |
| CW1_700_BR-RF (NED)  | 700-foot channel widening from Bolivar Roads to Redfish with 328-foot bend easings and transition to 530-foot existing channel at Sta. 74+119.99 | 5,031,000<br>(1,109,000 CY is in Mid Bay Segment from Sta 78+844 to 74+119) |
| <b>Redfish To BSC Station 78+844.001 - 28+605.055</b>            |  |   |
| CW1_700_RF-BSC (LPP)   | 700-foot channel widening from Redfish to BSC with 328-foot bend easings   | 7,685,000   |
| <b>BSC To BCC 28+605.055 - -0+003.944</b>                        |  |   |
| BE1_028+605_530 (NED)  | 328-foot bend on existing 530-foot channel at Sta. 28+605  | 425,000   |
| CW1_700_BSC-BCC (LPP)  | 700-foot channel widening from BSC to BCC with 328-foot bend easings   | 5,341,000   |

### 5.1.2 Segment 2: Bayport Ship Channel

The current BSC is 46.5 feet deep and approximately 400 feet wide from the start of the BSC Flare at approximate Station 221+00 to the land cut at 112+00. The remaining channel is 350 feet wide from Station 112+00 to 25+58 and includes a 1,600-foot turning basin at its terminus. The maintenance template was created with 2.5H:1V slope beginning at -46.5 feet MLLW with a box cut down to AO of -50.5 feet MLLW. All new work templates have 3H:1V slopes. Volumes for

the BSC Flare includes 7 feet of AM. The 2018 USACE single beam survey was added to the survey surface to more accurately determine NW dredging quantities after the recent dredging of the 4,000-foot BSC Flare. New work quantities calculated for the various BSC measures are provided in Table 5-4.

Table 5-4: New Work Quantities for Segment 2

| Measure                    | Description  | New Work Quantity (CY) |
|----------------------------|--|------------------------|
| CW2_BSC_455 (NED)          | Widen BSC to 455-FT  | 2,108,000              |
| BE2_BSCFlare (NED not LPP) | Widen south BSC Flare to 5,375-FT radius (Includes 7 feet of AM) | 1,925,000              |

### 5.1.3 Segment 3: Barbours Cut Channel

The entrance of the BCC is at Morgan's Point and approximate HSC Station 6+00 where the two channel centerlines meet, just north of the entrance to the Cedar Bayou Navigation Channel. The BCC is approximately 1.4 miles in length and approximately 300 feet wide, at a depth of -46.5 feet MLLW and includes a turning basin at its westernmost end. The turning basin is approximately 2,000 x 1,900 feet in dimension. The flare ranges from 300-foot-wide to 1,280-foot-wide at its intersection with the HSC. The BCC is bordered by Spilmans Island to the north, the Barbours Cut Container Terminal (BCCT), and Morgan's Point to the south.

The existing BCC template reflects the recent channel improvements that were completed in 2016 and discussed in Section 1.1.3. This includes a channel depth of -46.5 feet MLLW plus 2 feet of AM and 2 feet of AO. A portion of the north side of the channel from Station 20+13 to 65+43 was widened by 75 feet to maintain the 300-foot channel width. The authorized channel template was created with 2.5H:1V slope beginning at the authorized depth with a box cut down to AO. All new work templates have 3H:1V slopes. The BCC Flare is extended to the north and south to include an 1,800 foot diameter turning basin. Volumes for the BCC Flare includes 7 feet of AM. New work quantities calculated for the various BCC measures are provided in Table 5-5.

Table 5-5: New Work Quantities for Segment 3

| Measure                     | Description   | New Work Quantity (CY) |
|-----------------------------|---|------------------------|
| CW3_BCC_455 (NED)           | Widen BCC to 455-FT   | 1,202,000              |
| BETB3_BCCFlare_1800NS (NED) | Widen BCC N/S flare 1,800-FT diameter TB (Includes 7 feet AM) | 1,623,000              |



### 5.1.4 Segment 4: Boggy Bayou to Sims Bayou

Most of Segment 4 is 300 feet wide except where turning basins are located and a few small stretches of channel that are reduced to 200 and 280 feet. The current authorized depths for this segment of the HSC are provided in Table 5-6. The existing channel template was created with 2.5H:1V slope beginning at the authorized depth with a box cut down to AO. All new work templates have 3H:1V slopes. New work volumes for Segment 4 measures are provided in Table 5-7. The channel is widened along centerline shifts up to 530 feet from Boggy Bayou to Greens Bayou and deepened from -41.5 feet MLLW to -46.5 feet MLLW from Boggy Bayou to Hunting Bayou.,

Table 5-6: Currently Authorized Depths for Segment 4

| Channel Section  | Start Station | End Station | Authorized Depth (MLLW) | Advanced Maintenance (MLLW) | Allowable Overdepth (MLLW) |
|--|---------------|-------------|-------------------------|-----------------------------|----------------------------|
| Boggy Bayou to Greens Bayou  | 684+03.19     | 833+05.17   | 41.5                    | 43.5                        | 44.5                       |
| Greens Bayou to Sims Bayou <sup>1</sup>  | 833+05.17     | 1110+77.54  | 41.5                    | 43.5                        | 44.5                       |
| Note:<br><sup>1</sup> Washburn Tunnel from Station 977+92.5 to 974+07.5 is authorized to 41.5 feet, but is dredged to 38.5 feet, +2 feet AM, +1 foot AO. |               |             |                         |                             |                            |

Table 5-7: New Work Quantities for Segment 4

| Measure  | Description  | New Work Quantity (CY) |
|--|--|------------------------|
| CW4_BB-GB_530 (NED)  | Widen (530-FT)/Deepen (5-FT) Boggy Bayou to Greens Bayou | 2,412,000 <sup>1</sup> |
| CD4_Whole (NED)  | Deepen (5-FT) Boggy Bayou to Hunting Turning Basin       | 860,000                |
| Note:<br><sup>1</sup> Quantity excludes approximately 418,000 CY included with CD4 Whole |  |                        |

### 5.1.5 Segment 5: Sims Bayou to I-610 Bridge

This segment of the channel is 300 feet wide and has an authorized depth of -37.5 feet MLLW with 2 feet of AM and 1 foot of AO. The existing channel template was created with 2.5H:1V slope beginning at the authorized depth with a box cut down to -40.5 feet MLLW. The new work template has 3H:1V slopes. The new work volume for the deepening of Segment 5 from -37.5 feet MLLW to -41.5 feet MLLW is provided in Table 5-8.

Table 5-8: New Work Quantities for Segment 5

| Measure         | Description                                  | New Work Quantity (CY) |
|-----------------|--|------------------------|
| CD5_Whole (NED) | Deepen (4-FT) HSC Sims Bayou to I-610 Bridge | 176,000                |

### 5.1.6 Segment 6: I-610 Bridge to Turning Basin

This segment of the channel has an authorized depth of -37.5 feet MLLW with 2 feet of AM and 1 foot of AO. Apart from the Brady Island Turning Basin, the channel width is 300 feet from the I-610 Bridge to the start of the Main Turning Basin at Station 1266+48.72, where it is reduced to 250 feet. The existing channel template was created with 2.5H:1V slope beginning at the authorized depth with a box cut down to -40.5 feet MLLW. All new work templates have 3H:1V slopes. New work volumes for the deepening of Segment 6 from -37.5 feet MLLW to -41.5 feet MLLW is provided in Table 5-9.

Table 5-9: New Work Quantities for Segment 6

| Measure             | Description                                       | New Work Quantity (CY) |
|---------------------|---|------------------------|
| CD6_Whole (NED)     | Deepen (4-FT) HSC I-610 Bridge thru Turning Basin | 706,000                |
| TB6_Brady_900 (NED) | Turning Basin at Brady Island Station 1195+00     | 294,000                |

## 5.2 Shoaling Rates

### 5.2.1 Existing Shoaling Rates

Existing shoaling rates for the HSC were compiled from various sources and are outlined in Table 5-10, and do not include non-federal shoaling.

The Draft HSC Sedimentation Study (JV, 2012) estimated the shoaling rate of the 46.5-foot channels using survey data dating back to 1999 and included non-pay volumes. During the BSC and BCC widening and deepening projects an evaluation to estimate the increased shoaling rate from the planned channel modifications was conducted (JV, 2013). The Draft HSC Integrated Dredged Material Management Plan and Environmental Assessment (DMMP/EA) (USACE, 2019) provides estimated shoaling rates for the entire HSC system. Several of the shoaling rates for the 46.5-foot channels estimated in the JV studies have been utilized in this DMMP. The shoaling rates for the 41.5-foot and 37.5-foot channels were derived from the USACE Dredging Histories Database and do not include non-pay volumes. The USACE has adjusted the BSC and BCC shoaling rates using recent survey and dredging data. Due to variable high shoaling rates in the BSC Flare that may be due to recent flooding, the contingency placed on dredging the BSC

Flare was raised from 21% to 30%. The BCC shoaling rate from the 2013 JV study will continue to be used in this evaluation to remain conservative as the rate in the DMMP is slightly less.

Table 5-10: Existing Federal Shoaling Rates

| Channel Segment   | Channel Section                        | Existing Total Federal Shoaling Rates (CY/Year) |         | Average Dredging Cycle (Years) |
|---|--|---|---------|--------------------------------|
| 1   | Bolivar Roads to Redfish               | 99,194 <sup>1</sup>                             |         | 4                              |
|   | Redfish to BSC                         | 1,468,925 <sup>1</sup>                          |         | 3                              |
|   | BSC to BCC                             | 771,433 <sup>1</sup>                            |         | 3                              |
|   | BCC to Exxon                           | 1,240,802 <sup>1</sup>                          |         | 3                              |
|   | Exxon to Carpenters Bayou              | 454,759 <sup>2,4</sup>                          |         | 3                              |
|   | Carpenters Bayou to Boggy Bayou        | 194,478 <sup>2,4</sup>                          |         | 4                              |
| 2   | BSC Flare                              | 788,415 <sup>2</sup>                            |         | 1                              |
|   | BSC Channel & TB                       | 498,500 <sup>2</sup>                            |         | 4                              |
| 3   | BCC Flare                              | 168,992 <sup>3</sup>                            |         | 3                              |
|   | BCC Channel & Flare                    | 113,152 <sup>3</sup>                            |         | 3                              |
| 4   | Boggy Bayou to Greens Bayou            | 113,709 <sup>2,4</sup>                          | 329,371 | 4-5                            |
|   | Greens Bayou to Sims Bayou             | 215,662 <sup>2,4</sup>                          |         |                                |
| 5   | Sims Bayou to I-610 Bridge             | 38,751 <sup>2,4,5</sup>                         |         | 3                              |
| 6   | I-610 Bridge to End Main Turning Basin | 180,416 <sup>2,4,5</sup>                        |         | 3                              |
| Notes:  |  |   |         |                                |
| <sup>1</sup> Existing shoaling rate from Draft HSC Sedimentation Study (JV, 2012), does not include non-Federal facilities.   |  |   |         |                                |
| <sup>2</sup> Existing shoaling rate from the Draft HSC Integrated Dredged Material Management Plan and Environmental Assessment (USACE, 2019)   |  |   |         |                                |
| <sup>3</sup> Estimated Shoaling rate post BSC and BCC Channel Improvement Projects (JV, 2013)   |  |   |         |                                |
| <sup>4</sup> Existing shoaling rates removed annual non-federal shoaling rate (gross volume) of the docks.  |  |   |         |                                |
| <sup>5</sup> The DMMP provides shoaling quantities for Sims Bayou to the Main Turning Basin, which are separated into two segments for the HSC-ECIP study. The shoaling rate was portioned between segments based on the area between channel toes. |  |   |         |                                |

### 5.2.2 Estimated Shoaling Rates

The existing shoaling rate and area of the nearest section of channel was used to determine the approximate shoaling rate for the various channel measures. The assumption was made that the existing shoaling rate will increase by the same rate as the increased project footprint. This method was used for all measures where there would be an alteration in the channel footprint from channel widening, bend easings, mooring facilities, and turning basins. Using this method, the assumption is made that shoaling occurs uniformly over the entire section of the existing channel and will continue to shoal at the same rate in the newly dredged area. Estimated shoaling for project measures is provided below in Table 5-11.

Table 5-11: Estimated Shoaling Rates

| SEG  | Measure                         | (A)                            | (B)                              | (C)                                 | (D) = (C/B)        | (E) = (D x A)             | (F) = (E - A)                |
|--|---------------------------------|--------------------------------|----------------------------------|-------------------------------------|--------------------|---------------------------|------------------------------|
|  |                                 | Existing Shoaling Rate (CY/Yr) | Area of Existing Channel (Sq Ft) | Increased Area with Measure (Sq Ft) | % Increase in Area | New Shoaling Rate (CY/Yr) | Incremental Shoaling (CY/Yr) |
| 1  | CW1_BR-Redfish_700              | 99,000                         | 30,885,000                       | 46,938,000                          | 152%               | 151,000                   | 52,000                       |
|  | CW1_BR-Redfish_700 <sup>1</sup> | 99,000                         | 30,885,000                       | 42,223,000                          | 137%               | 136,000                   | 36,000                       |
|  | CW1_Redfish-BSC_700             | 1,469,000                      | 27,030,000                       | 37,200,000                          | 138%               | 2,022,000                 | 553,000                      |
|  | CW1_BSC-BCC_700                 | 771,000                        | 15,372,000                       | 20,415,000                          | 133%               | 1,025,000                 | 253,000                      |
|  | BE1_028+605_530 <sup>2</sup>    | 771,000                        | 15,372,000                       | 15,887,000                          | 103%               | 797,000                   | 26,000                       |
|  |                                 | 1,469,000                      | 27,030,000                       | 28,295,000                          | 104%               | 1,538,000                 | 69,000                       |
| 2  | CW2_BSC_455                     | 449,000                        | 7,945,000                        | 9,292,000                           | 117%               | 583,000                   | 84,000 (Channel)             |
|  |                                 | 788,000                        | 4,128,000                        | 4,355,000                           | 106%               | 832,000                   | 44,000 (Flare)               |
|  | BE2_BSCFlare                    | 788,000                        | 4,128,000                        | 5,737,000                           | 139%               | 1,096,000                 | 308,000                      |
| 3  | CW3_BCC_455                     | 113,000                        | 4,555,000                        | 5,070,000                           | 111%               | 126,000                   | 13,000 (Channel)             |
|  |                                 | 169,000                        | 1,204,000                        | 1,269,000                           | 105%               | 178,000                   | 9,000 (Flare)                |
|  | BETB3_BCCFlare 1800             | 169,000                        | 1,204,000                        | 2,556,000                           | 212%               | 359,000                   | 190,000                      |
| 4  | CW4_BB-GB_530                   | Refer to Table 5-12            |                                  |                                     |                    |                           |                              |
|  | CD4_Whole                       |                                |                                  |                                     |                    |                           |                              |
| 5  | CD5_Whole                       | Refer to Table 5-12            |                                  |                                     |                    |                           |                              |
| 6  | CD6_Whole                       | Refer to Table 5-12            |                                  |                                     |                    |                           |                              |
|  | TB6_Brady_900                   |                                |                                  |                                     |                    |                           |                              |
| Notes:   |                                 |                                |                                  |                                     |                    |                           |                              |
| <sup>1</sup> With the LPP the entire HSC Bay will be widened to 700-ft and will not require the transition back to the 530-ft channel. |                                 |                                |                                  |                                     |                    |                           |                              |
| <sup>2</sup> Measure BE1_028+605_530 falls between two bay sections of the HSC, Redfish-BSC and BSC-BCC.                               |                                 |                                |                                  |                                     |                    |                           |                              |

The shoaling rate for channel deepening measures in Segments 4, 5, and 6 could not be determined from the percent increase in project area, as the footprint does not change. For these measures the “Volume of Cut” method was used to estimate the change in shoaling rate. The methodology used was that described in “Basics of Channel Deposition/Siltation” (van Rijn, 2013). Results are provided below in Table 5-12. More detailed analysis of the existing and projected shoaling rates will be conducted during PED and will incorporate the findings of the sediment transport modeling.

Table 5-12: Estimated Shoaling Rates using Volume of Cut Method

| Segment   | 4                          |            | 5          | 6                                     |           |
|---|----------------------------|------------|------------|---------------------------------------|-----------|
| Measure   | CW4_BB-GB_530 <sup>1</sup> | CD4_Whole  | CD5_Whole  | CD6_Whole<br>(Includes TB6 Brady_900) |           |
| Parts   | BB-GB                      | GB-Hunting | SB-610     | 610-TB                                | TB        |
| Station to  | 684+03.19                  | 833+05.17  | 1110+77.54 | 1160+62.20                            | 00+00.00  |
| Station   | 833+05.17                  | 974+07.50  | 1160+62.20 | 1266+48.00                            | 30+95.00  |
| Distance (FT)   | 14,902                     | 14,102     | 4,985      | 10,586                                | 3,095     |
| W <sub>existing</sub> (FT)  | 300                        | 300        | 300        | 300                                   | 300       |
| W <sub>proposed</sub> (FT)  | 530                        | 300        | 300        | 300                                   | 300       |
| D <sub>existing</sub> (FT)  | 41.5                       | 41.5       | 37.5       | 37.5                                  | 37.5      |
| D <sub>proposed</sub> (FT)  | 46.5                       | 46.5       | 41.5       | 41.5                                  | 41.5      |
| V <sub>old, cut</sub> (CY)  | 6,871,000                  | 6,503,000  | 2,077,000  | 4,782,000                             | 2,073,000 |
| V <sub>new, cut</sub> (CY)  | 12,586,000                 | 7,286,000  | 2,298,000  | 5,748,000                             | 2,294,000 |
| I <sub>cut</sub>  | 0.83                       | 0.06       | 0.11       | 0.20                                  | 0.11      |
| V <sub>old, md</sub> (CY/YR)  | 113,709                    | 215,662    | 38,751     | 75,327                                | 105,089   |
| V <sub>new, md</sub> (CY/YR)  | 208,000                    | 229,000    | 43,000     | 91,000                                | 116,000   |
| R <sub>inc.</sub> (CY/YR)   | 94,291                     | 13,338     | 4,249      | 15,673                                | 10,911    |
| Note:<br><sup>1</sup> The shoaling rate for the channel deepening measure CD4_Whole between Boggy Bayou and Greens Bayou is included in the channel widening and deepening measure CW4_BB-GB_530. |                            |            |            |                                       |           |

### 5.2.3 Shoaling Estimate from the Numerical Model

The sediment analysis is based on the historic dredge records from the USACE annual reports as done in the model validation (McAlpin et al. 2019a) as shown Houston Ship Channel and Vicinity Three-Dimensional Adaptive Hydraulics (AdH) Numerical Model Calibration/ Validation Report included in Attachment 4a. These volumes are provided for several reaches of the HSC as noted in the dredge template shown in Figure 5-2. This template will be used to show how the alternative shoaling estimates from the numerical model compare to each other for each channel reach. The numerical model computed shoaling results are scaled based on the historic dredge records. For further information on this numerical model, please see the ERDC technical report (McAlpin et al., 2019b) Houston Ship Channel Expansion Channel Improvement Project (ECIP) Numerical Modeling Report included in Attachment 4b.

Figure 5-3 shows the model computed, scaled shoaling volume within each segment for the 2010 base condition and all four alternatives – present with project (PWP), present without project (PWOP), future with project (FWP), and future without project (FWOP). The with-project shoaling is larger for all segments except at the furthest upstream and downstream segments. Bolivar Roads to Redfish indicates a small decrease in the shoaling with the project changes in place likely due to the slight increase in the tidal prism which will generate some higher velocity

magnitudes. The BSC area shows the largest increase in shoaling volume. The BSC Flare is already a sediment trap due to its present size and the project alternative of widening the BSC and to ease the bend further increase the footprint and therefore the tendency to trap sediment.

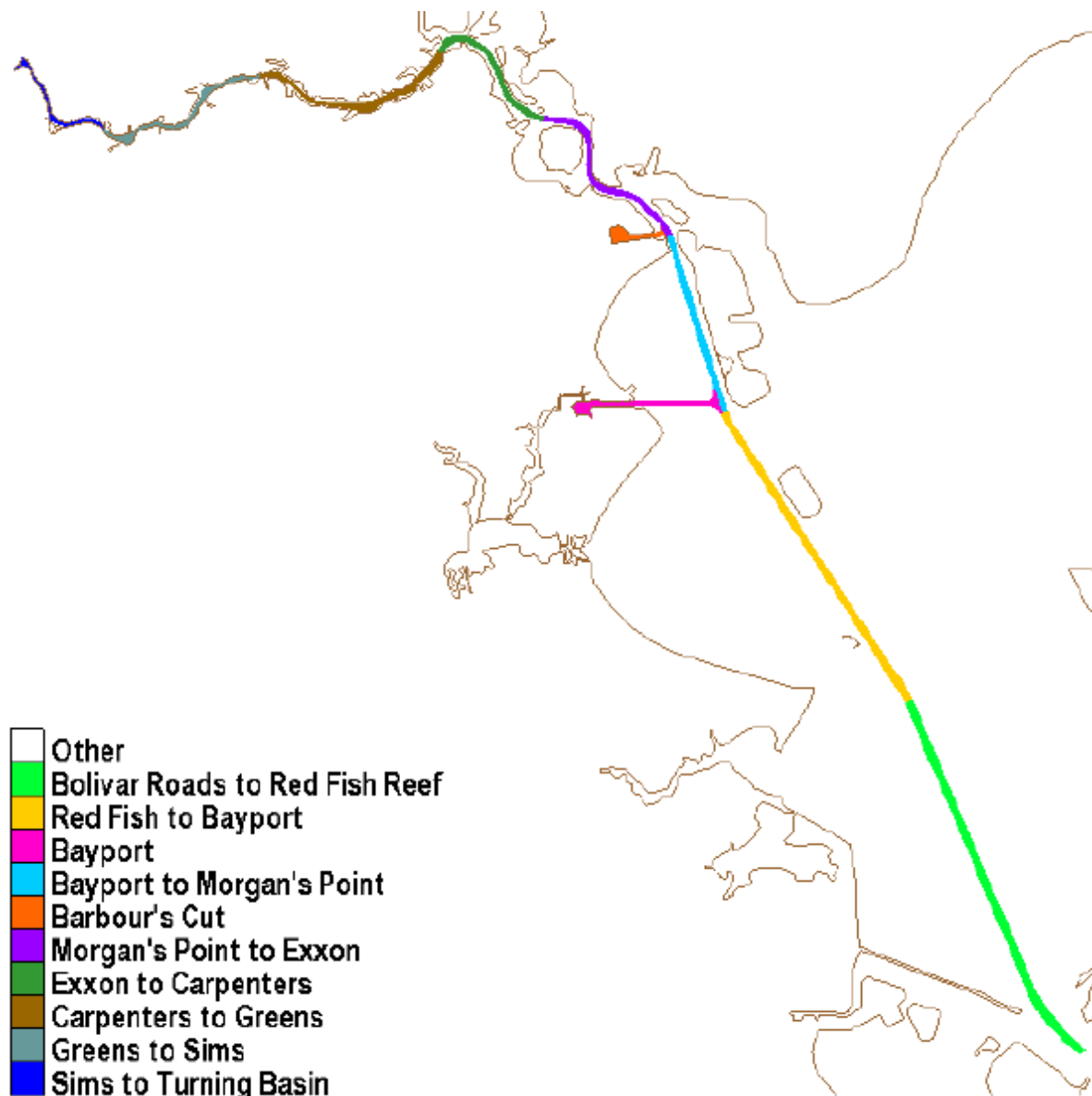

Figure 5-2: HSC dredge template for shoaling analysis

Figure 5-4 shows the model computed, unscaled bed displacement along the HSC from the Texas City Dike to the HSC Turning Basin. These results show a similar pattern to those in Figure 5-3, although no scaling has been done to ensure a correlation to historic data as in the shoaling volume plot. However, the comparison between with and without project will remain if scaled to replicate actual shoaling volumes/depths. The plot does show that the with project alternatives increase the deposition along most of the HSC. It also indicates a potential shift in the shoaling locations for

the PWP alternative to areas upstream of Redfish and up-stream of BSC. The increase upstream of BSC may actually be a simple increase in shoaling as opposed to a shift since there are still peaks in the bed displacement at the BSC Flare. It is not uncommon for channel modifications to change the flow patterns such that the turbidity maximum (the location where the sediment tends to collect and often tied to the location of the salinity wedge) moves upstream, especially in the

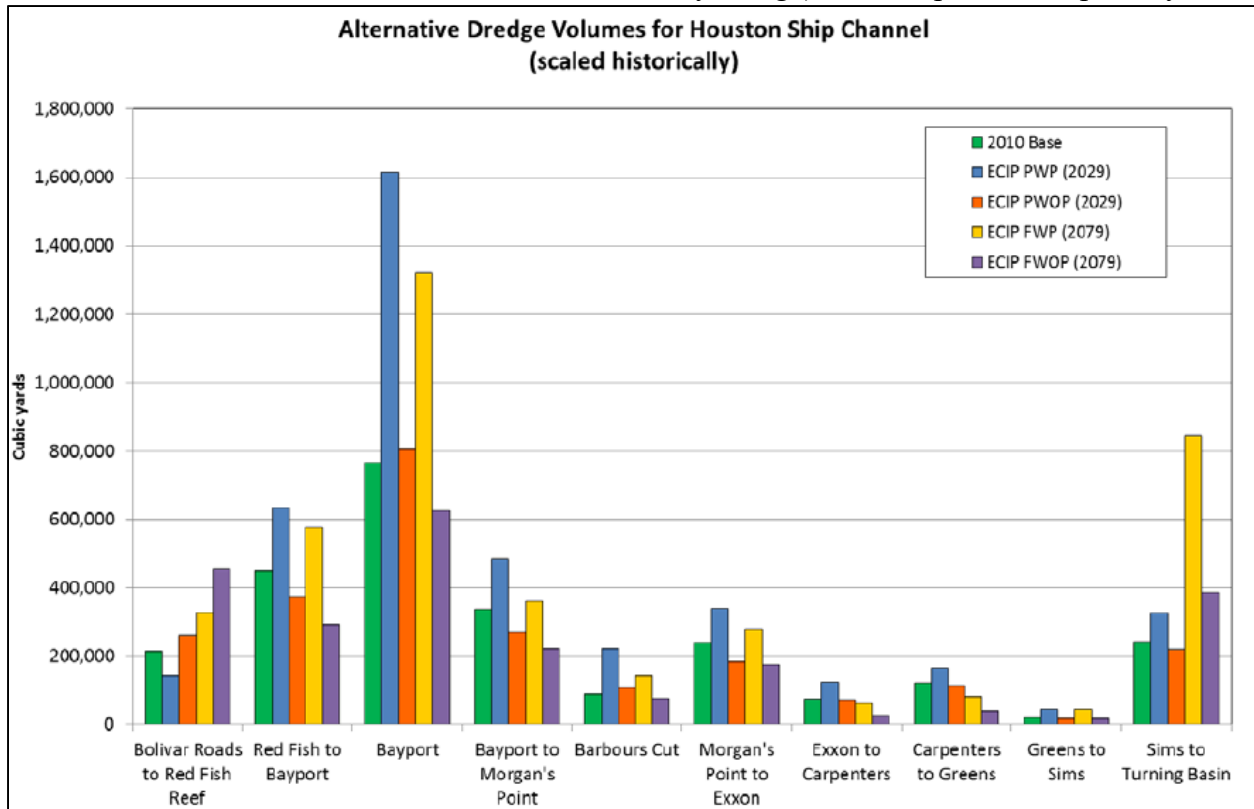

Figure 5-3. Shoaling results by reach for alternatives

case of channel deepening. The future alternatives do not show this shift most likely because the sediment loads are reduced in the future condition simulations.

The deepened portion of the HSC in the project alternatives is located up-stream of the San Jacinto River. Sediment loads from the bayous entering the HSC in the area of the deepening may have a tendency to migrate up-stream due to the salinity being pushed further upstream along the channel bottom; although the salinity change is less than 1 ppt for most of this area. This model does not include these bayou sediment loads because they are unknown and therefore is unable to predict this potential up-stream sediment migration.

Due to the increase in the with project cross sectional area (where the HSC is being widened or deepened), the same shoaling volume will equate to a reduced shoaling depth for the larger cross section. Figure 5-5 shows schematically how the shoaling volume can be interpreted for different channel modifications. A wider channel and the same shoaling depth or elevation will produce a larger shoaling volume. So the increased shoaling volume does not mean dredging must occur

sooner, but it does indicate the dredging may cost more due to more volume. A constant shoaling volume will mean a lower shoaling depth for a channel widening condition; therefore, again, the dredging may not be required as often. For a deepened channel condition, the same results are true as in the widened condition; however, for a constant shoaling elevation, the shoaling volume and depth will be increased but dredging will only be required more often if the required dredging elevation is also deepened. These conditions should be considered when viewing the modeled shoaling volume and bed displacement changes for the various locations along the HSC due to the different areas of deepening and widening.

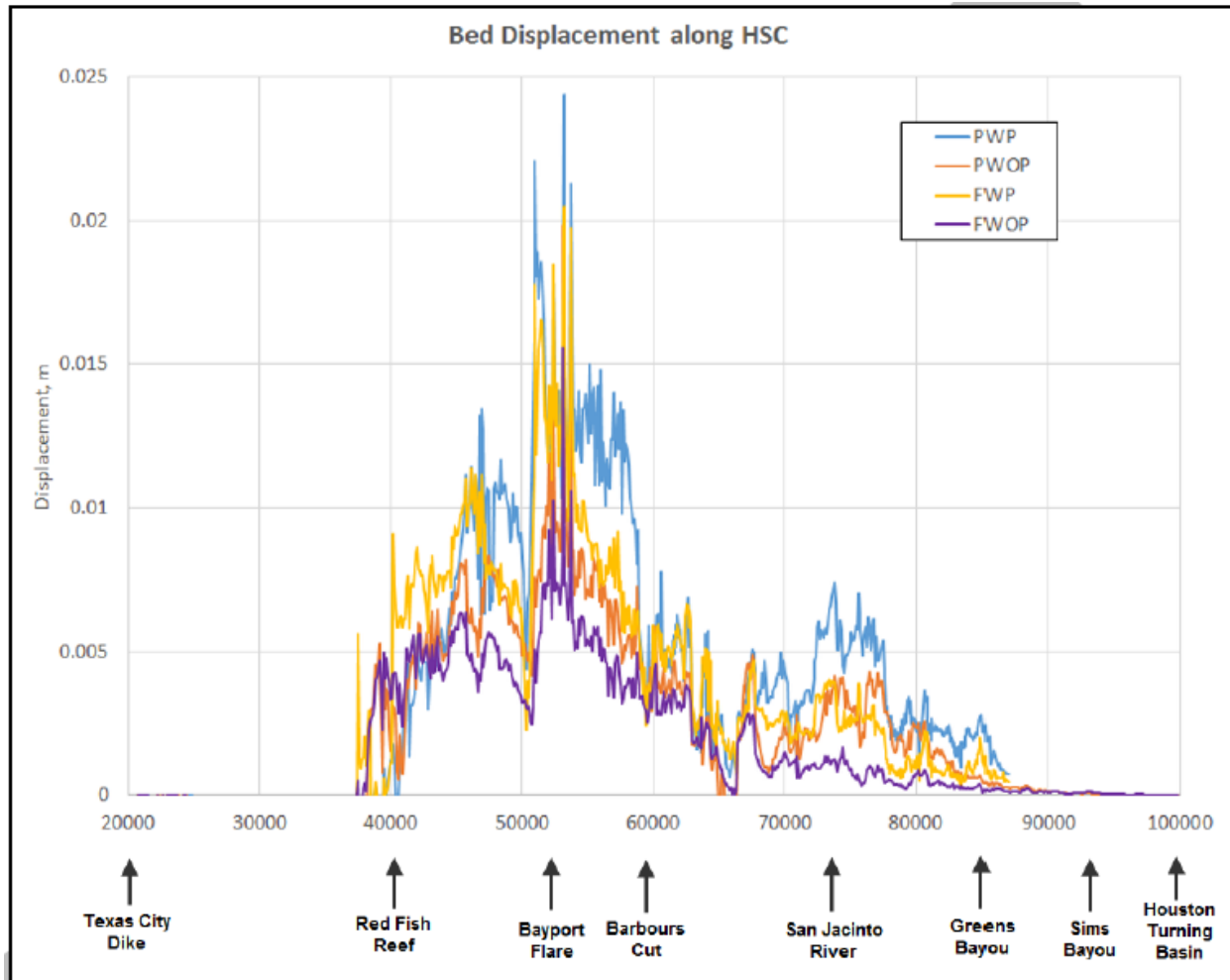

Figure 5-4. Modeled bed displacement along HSC (non-scaled, focus on the change; \* Focus separately on changes between the present and future to isolate project impacts).



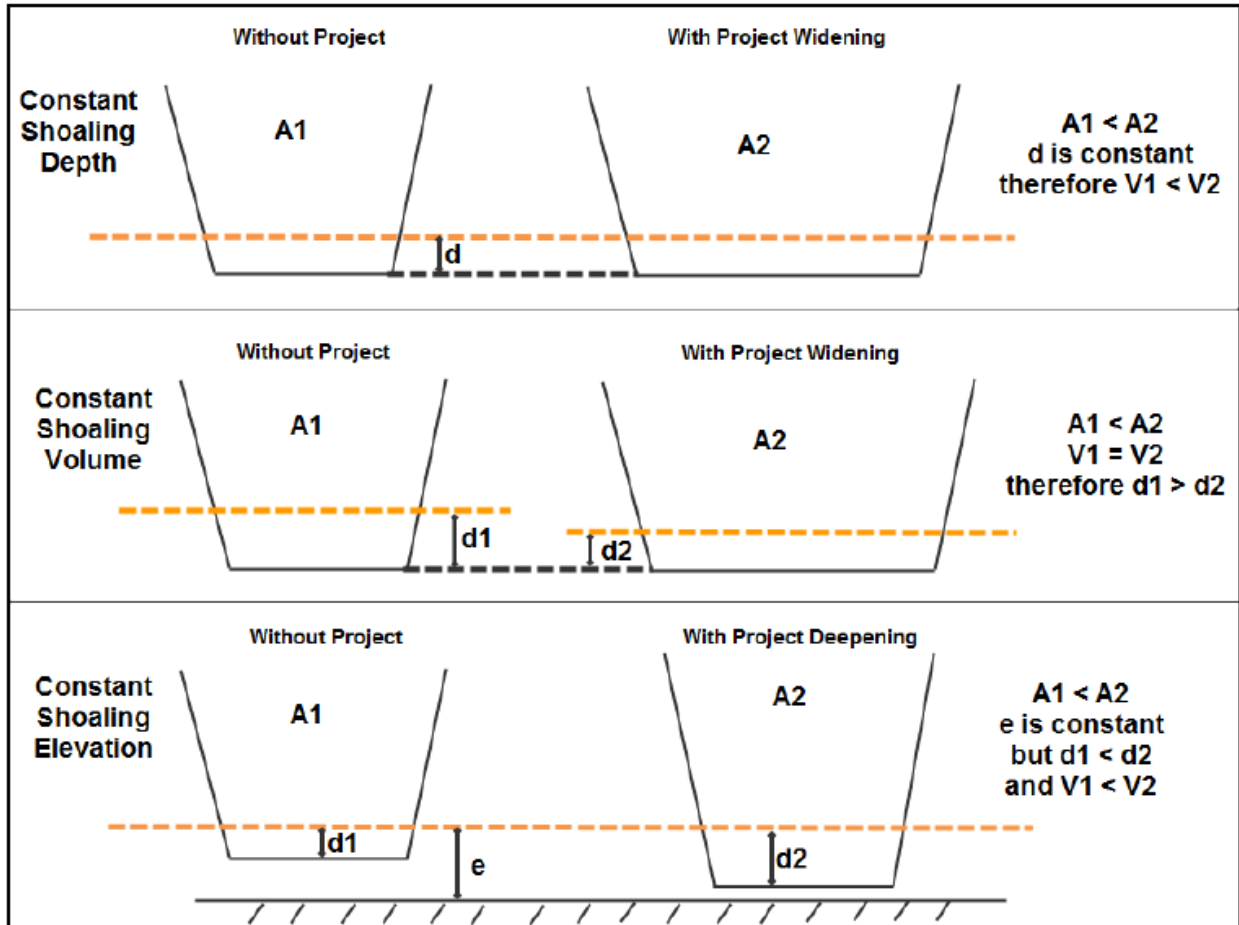

Figure 5-5. Shoaling impacts under various alternative conditions (\*Focus separately on changes between the present and future to isolate project impacts)

#### 5.2.4 Sediment Model Calibration to Corps Shoaling Analysis Tool (CSAT) Estimates

An additional sediment model calibration effort, is performed using the Corps Shoaling Analysis Tool (CSAT). This tool computes historic shoaling rates and provides estimates of future rates on a fine scale (10ft). This calibration effort provides shoaling estimates similar to those presented in the previous section but on a finer scale than the dredge template allows.

All previous sediment results with the numerical model has applied a historical scale factor based on seven years of dredge volumes (post 40x530 ft construction) provided in the USACE Annual Reports. These reports are best viewed over several years since some reaches are not dredged every year. The CSAT analysis was performed on data from 2011-2013. The USACE Annual Reports are not available beyond 2012. However, the total shoaling estimates for the entire HSC for 2011 and 2012 are comparable to the CSAT shoaling estimate for 2011-2013: although there are large differences in some of the reach shoaling volumes (see Table 5-13). (CSAT reaches were combined to match the analysis reaches shown in Figure 5-2). Presently there is no explanation

as to why there are such large differences between the Annual Report reach volumes and the CSAT reach volumes.

Table 5-13: Comparisons by reach for Annual Report data and CSAT estimates of shoaling volume for the HSC

| HSC Reach                 | 2011 (CY) | 2012 (CY) | Avg (CY)/Yr      | CSAT 2011-2013 Volume (CY) |
|---------------------------|-----------|-----------|------------------|----------------------------|
| Bolivar Roads to Red Fish |           |           | <b>0</b>         | <b>935,032</b>             |
| Red Fish to Bayport       |           | 1,946,206 | <b>973,103</b>   | <b>926,405</b>             |
| Bayport                   | 741,492   | 176,916   | <b>459,204</b>   | <b>802,561</b>             |
| Bayport to Morgan's Point | 914,986   |           | <b>457,493</b>   | <b>231,949</b>             |
| Barbours Cut              | 7,362     |           | <b>3,681</b>     | <b>169,650</b>             |
| Morgan's Point to Exxon   | 2,024,913 |           | <b>1,012,457</b> | <b>472,026</b>             |
| Exxon to Carpenters       | 64,535    | 3,543,921 | <b>1,804,228</b> | <b>228,338</b>             |
| Carpenters to Greens      |           |           | <b>0</b>         | <b>192,423</b>             |
| Greens to Sims            |           | 431,216   | <b>215,608</b>   | <b>377,957</b>             |
| Sims to Turning Basin     | 130,347   |           | <b>65,174</b>    | <b>167,909</b>             |
| SUM                       | 3,883,635 | 6,098,259 | <b>4,990,947</b> | <b>4,504,250</b>           |

The CSAT results were analyzed over the Annual Report reaches and a scale factor determined such that the numerical model results could be adjusted to better match the CSAT values. The average of the model shoaling results for 2005, 2010, and 2011 (the model validation years) for each reach were used to compare back to the CSAT results and a scale factor determined. Figure 5-6 shows the results of the various scaling options. The Annual Report volumes and the CSAT volume analysis results are considered “data”. The numerical model computed results scaled in various ways are listed as “model”. The green data sets are model shoaling volumes scaled by the 2005 historic Annual Report data as documented in Attachment 4a (McAlpin et al. 2019a). The pink data sets are the model shoaling volumes scaled by the CSAT to 2011 model shoaling results (the 2011 pink bar matches the red CSAT bar). The dark blue model data sets are model shoaling volumes scaled by the CSAT to 2005, 2010, and 2011 average model shoaling results. The 2011 scaling option produces extremely large shoaling volumes at reaches in the upper HSC which are likely incorrect since they are so much larger than the Annual Report values and CSAT values. However, the CSAT maximum values do reach some extremely large shoaling volumes. Scaled results that fall in the general range of the Annual Report data and the CSAT data are considered more reliable at this time.

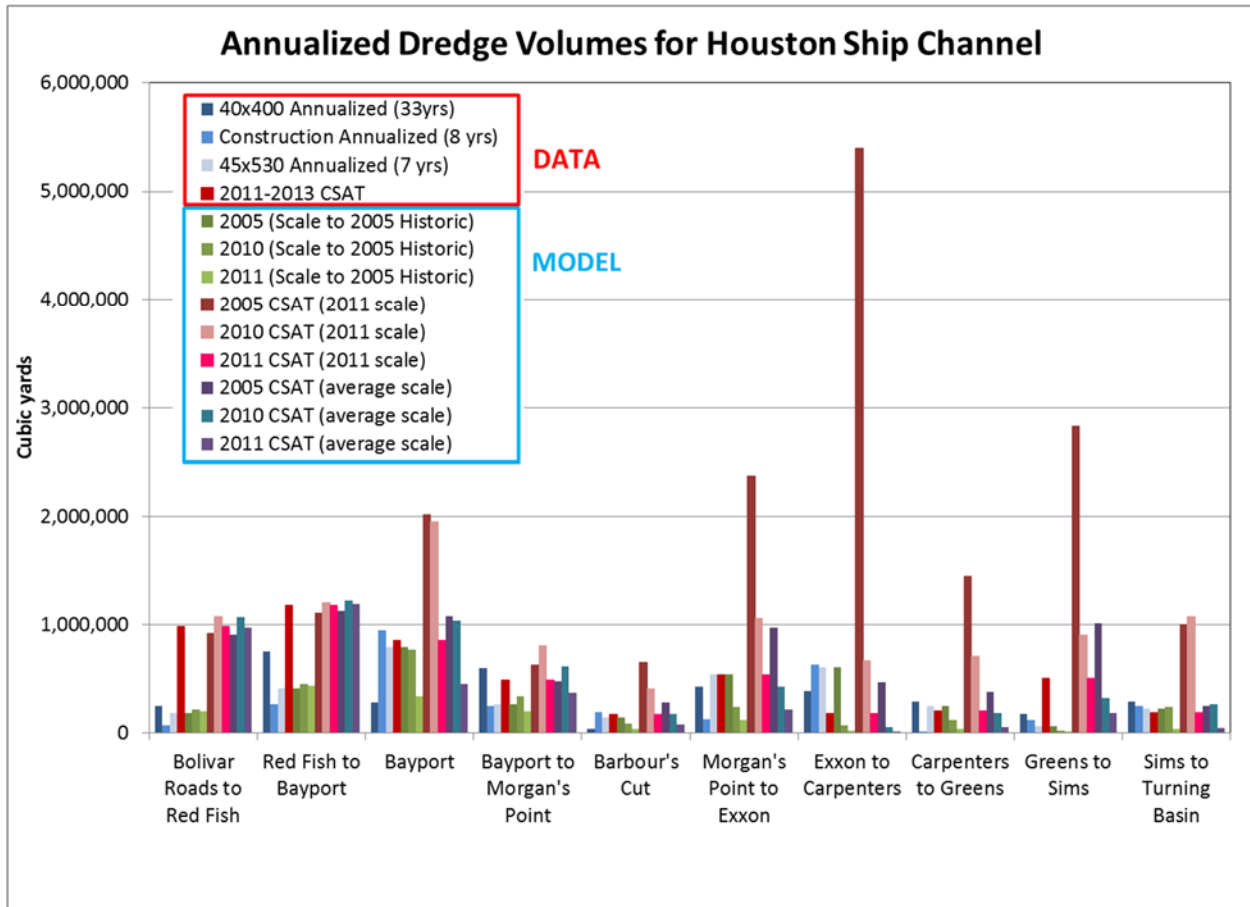

Figure 5-6: AdH Model Scaled Shoaling Results

The CSAT scaling of the numerical model results using the average shoaling of the three validation years is applied to the four ECIP alternatives – present with project (PWP), present without project (PWOP), future with project (FWP), and future without project (FWOP) – over the Annual Report reaches. The results for both the historic Annual Report scaling (as presented in the ECIP modeling report) and the CSAT scaling are shown in Figure 5-7 along with the CSAT computed volume for each reach (red). The CSAT scaling generates higher shoaling volumes than the Annual Report scaling although most reaches do not show extreme differences (more than double) except Bolivar Roads to Redfish and Greens Bayou to Sims Bayou.

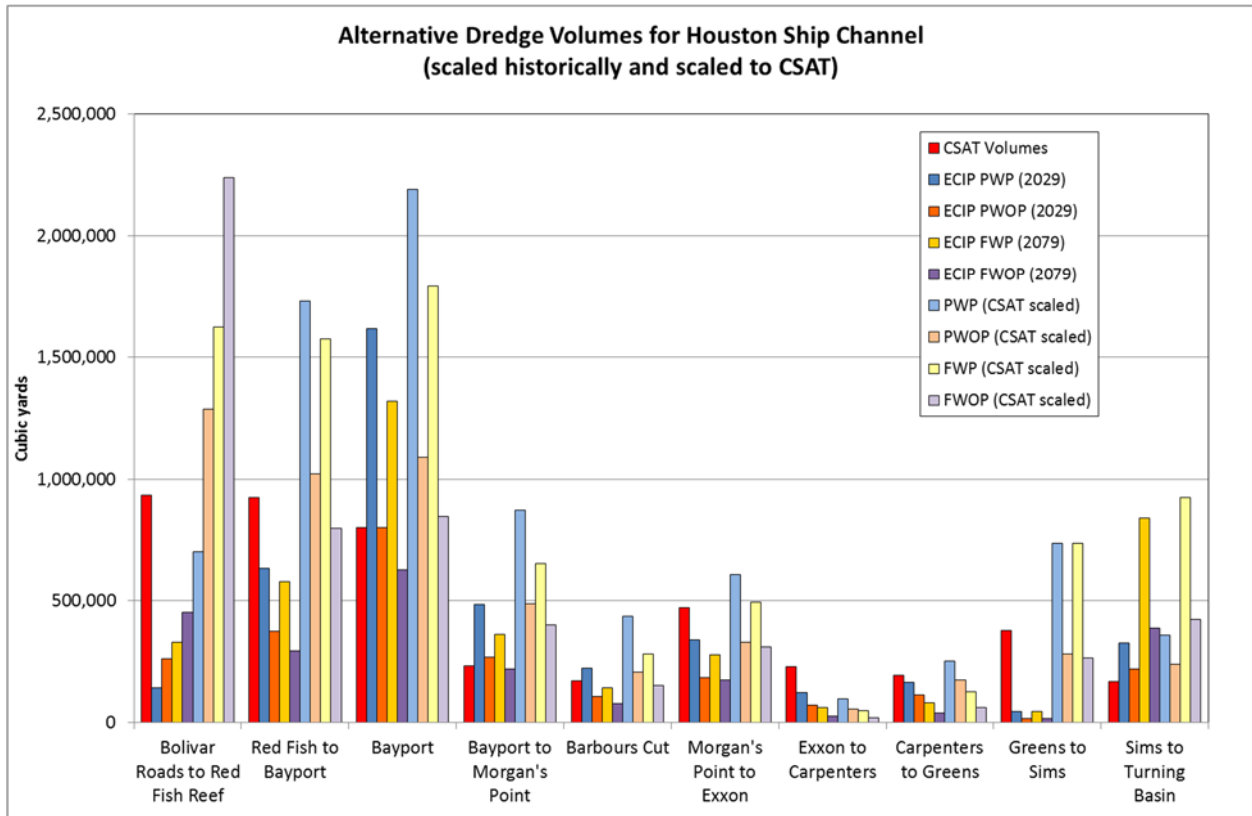

Figure 5-7: ECIP Alternative Scaled AdH Model Shoaling Volume Results for Annual Report reaches

The AdH shoaling validation effort using CSAT data provides a much larger range of possible shoaling results for the HSC reaches as compared to the USACE Annual Report validation effort presented in Attachment 4a (McAlpin et al. 2019a). The total shoaling for the HSC is comparable among the two data sources but the reach information varies drastically in some sections. The analysis years are not identical between the two methods which can present uncertainties given the variability of drought and flood years. Also creating discrepancies is the fact that the reaches are defined differently between the two data sources. However, the two methods present a possible range of shoaling to be expected along sections of the HSC under various flow conditions

### 5.2.5 Local Service Facilities

Economic analysis for the HSC ECIP has identified 21 Local Service Facilities (LSF) that would provide economic benefits from the channel modification/improvements as shown in Figure 5-8.

To estimate the total quantity of NW materials and 50-year maintenance quantities the area of each berthing facility was determined. CADD files were provided for the new Magellan, Contanda, and ITC facilities. The limits of the remaining facilities were approximated from permit documents, and/or NOAA charts. The footprint of each facility was limited to the toes of the 530-foot channel widening template from Boggy Bayou to Greens Bayou, and to the limits of the existing channel toes from Greens Bayou onward. This process is highlighted in Figure 5-9, with the dredging footprint of the Enterprise 1A facility in magenta limited to the proposed 530-foot channel toes in blue.

Existing berthing depths and proposed FWP deepening for existing facilities were provided by the PHA. The new facilities that were designed before the HSC ECIP and the proposed 5-foot channel deepening assume an existing FWOP and FWP depth as the adjacent channel to that facility.

Existing non-federal shoaling rates for the docks were held from the FWOP. These were listed as 0 CY/YR, 1,709 CY/YR, and 34,115 CY/YR for Boggy to Greens,

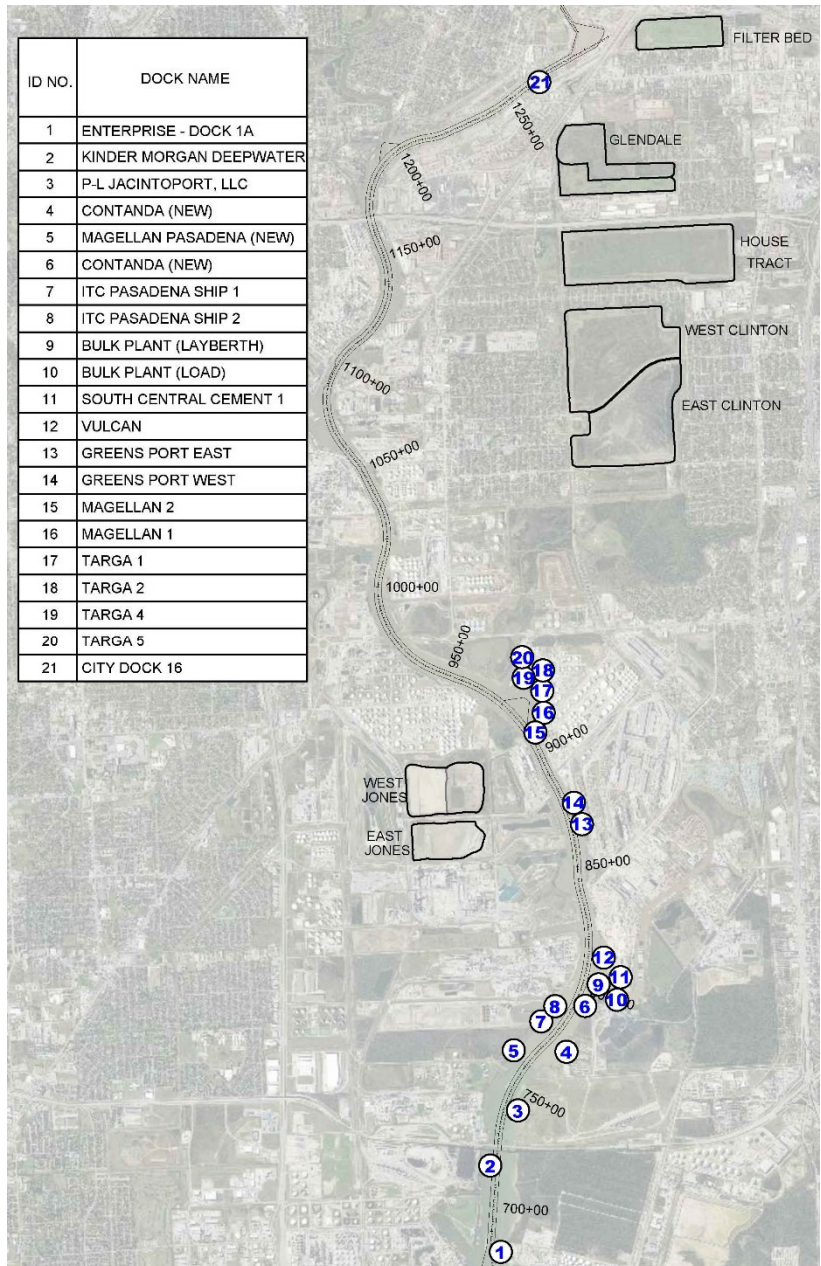

Figure 5-8: LSFs projected to benefit from the HSC ECIP

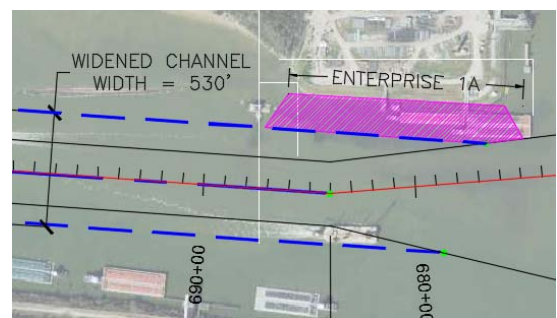

Figure 5-9: Estimating LSF footprint



Greens to Sims, and 610 to Main Turning Basin, respectively, for the 21 affected LSFs. In order to estimate shoaling rates for the FWP deepened docks, the Volume-of-Cut method was again used. In order to use this method theoretical shoaling rates for the existing condition were estimated by applying the existing channel shoaling rate per square foot to the footprint area of the LSFs. Once this rate was developed, the increased shoaling rate due to the 5-foot cut volume was determined. The shoaling quantities for the 21 affected LSFs are provided in the Tables 5-13 and 5-14.

Table 5-14: LSF New Work Quantities

| LSF                     | FWOP Depth (MLLW) | FWP Depth (MLLW) | A                    | B  | A x B          |
|-------------------------|-------------------|------------------|----------------------|--|----------------|
|                         |                   |                  | FWP Deepening (FEET) | Approximate Area Of Dock Footprint Outside 530-FT Widening (SQ FT) | NW (CY)        |
| Enterprise - Dock 1A    | 41.5'             | 46.5'            | 5                    | 194,655  | 36,000         |
| Kinder Morgan Deepwater | 41.5'             | 46.5'            | 5                    | 121,682  | 23,000         |
| ITC Pasadena Ship 1     | 41.5'             | 46.5'            | 5                    | 473,460  | 88,000         |
| ITC Pasadena Ship 2     | 41.5'             | 46.5'            | 5                    | 335,108  | 62,000         |
| Bulk Plant (Lay Berth)  | 41.5'             | 46.5'            | 5                    | 39,880   | 7,000          |
| Bulk Plant (Load)       | 41.5'             | 46.5'            | 5                    | 38,795   | 7,000          |
| South Central Cement 1  | 41.5'             | 46.5'            | 5                    | 159,787  | 30,000         |
| Vulcan                  | 41.5'             | 46.5'            | 5                    | 292,191  | 54,000         |
| Greens Port East        | 40.5'             | 46.5'            | 6                    | 197,972  | 44,000         |
| Greens Port West        | 39.5'             | 46.5'            | 7                    | 273,460  | 71,000         |
| Magellan 2              | 41.5'             | 46.5'            | 5                    | 201,739  | 37,000         |
| Magellan 1              | 41.5'             | 46.5'            | 5                    | 398,703  | 74,000         |
| Targa 1                 | 41.5'             | 46.5'            | 5                    | 189,457  | 35,000         |
| Targa 2                 | 41.5'             | 46.5'            | 5                    | 157,725  | 29,000         |
| Targa 4                 | 41.5'             | 46.5'            | 5                    | 334,904  | 62,000         |
| Targa 5                 | 41.5'             | 46.5'            | 5                    | 472,252  | 87,000         |
| City Dock 16            | 36.5'             | 37.5'            | 1                    | 36,816   | 1,000          |
|                         |                   |                  |                      | <b>TOTAL</b>   | <b>747,000</b> |

Table 5-15: LSF O&M Quantities

| NAME                          | Area (SF) | FWOP Depth (MLLW) | V <sub>old, cut</sub> CY | FWP Deepening (FEET) | FWP DEPTH (MLLW) | V <sub>new, cut</sub> CY | I <sub>out</sub> | Existing Channel Shoaling Adjacent (CY/YR) | Existing Adjacent Channel Area (SF) | FWOP Docks V <sub>old, md</sub> (CY/YR) | FWP Docks V <sub>new, md</sub> (CY/YR) | INCR. R <sub>inc</sub> (CY/YR) |
|-------------------------------|-----------|-------------------|--------------------------|----------------------|------------------|--------------------------|------------------|--|-------------------------------------|---|--|--------------------------------|
| P-L Jacintoport, LLC (NEW)    | 1,548,626 | 41.5              | 2,380,000                | 5                    | 46.5             | 2,667,000                | 0.12             | 113,709                                    | 4,470,594                           | 39,389                                  | 44,139                                 | 4,750                          |
| CONTANDA (NEW)                | 1,239,504 | 41.5              | 1,905,000                | 5                    | 46.5             | 2,135,000                | 0.12             | 113,709                                    | 4,470,594                           | 31,527                                  | 35,333                                 | 3,806                          |
| MAGELLAN PASADENA (NEW)       | 1,733,641 | 41.5              | 2,665,000                | 5                    | 46.5             | 2,986,000                | 0.12             | 113,709                                    | 4,470,594                           | 44,095                                  | 49,406                                 | 5,311                          |
| CONTANDA (NEW)                | 772,363   | 41.5              | 1,187,000                | 5                    | 46.5             | 1,330,000                | 0.12             | 113,709                                    | 4,470,594                           | 19,645                                  | 22,012                                 | 2,367                          |
| ITC Pasadena Ship 1 EXPANSION | 240,439   | 41.5              | 370,000                  | 5                    | 46.5             | 414,000                  | 0.12             | 113,709                                    | 4,470,594                           | 6,116                                   | 6,843                                  | 727                            |
| Kinder Morgan Deepwater       | 121,682   | 41.5              | 187,000                  | 5                    | 46.5             | 210,000                  | 0.12             | 113,709                                    | 4,470,594                           | 3,095                                   | 3,476                                  | 381                            |
| ITC Pasadena Ship 1 EXISTING  | 473,460   | 41.5              | 728,000                  | 5                    | 46.5             | 815,000                  | 0.12             | 113,709                                    | 4,470,594                           | 12,042                                  | 13,482                                 | 1,439                          |
| ITC Pasadena Ship 2           | 335,108   | 41.5              | 515,000                  | 5                    | 46.5             | 577,000                  | 0.12             | 113,709                                    | 4,470,594                           | 8,523                                   | 9,550                                  | 1,026                          |
| Bulk Plant (Lay Berth)        | 39,880    | 41.5              | 61,000                   | 5                    | 46.5             | 69,000                   | 0.13             | 113,709                                    | 4,470,594                           | 1,014                                   | 1,147                                  | 133                            |
| Bulk Plant (Load)             | 38,795    | 41.5              | 60,000                   | 5                    | 46.5             | 67,000                   | 0.12             | 113,709                                    | 4,470,594                           | 987                                     | 1,102                                  | 115                            |
| South Central Cement 1        | 159,787   | 41.5              | 246,000                  | 5                    | 46.5             | 275,000                  | 0.12             | 113,709                                    | 4,470,594                           | 4,064                                   | 4,543                                  | 479                            |
| Vulcan                        | 292,191   | 41.5              | 449,000                  | 5                    | 46.5             | 503,000                  | 0.12             | 215,662                                    | 4,470,594                           | 14,095                                  | 15,791                                 | 1,695                          |
| Greens Port East              | 197,972   | 40.5              | 297,000                  | 6                    | 46.5             | 341,000                  | 0.15             | 215,662                                    | 9,722,482                           | 4,391                                   | 5,042                                  | 651                            |
| Greens Port West              | 273,460   | 39.5              | 400,000                  | 7                    | 46.5             | 471,000                  | 0.18             | 215,662                                    | 9,722,482                           | 6,066                                   | 7,143                                  | 1,077                          |
| Magellan 2                    | 201,739   | 41.5              | 310,000                  | 5                    | 46.5             | 347,000                  | 0.12             | 215,662                                    | 9,722,482                           | 4,475                                   | 5,009                                  | 534                            |
| Magellan 1                    | 398,703   | 41.5              | 613,000                  | 5                    | 46.5             | 687,000                  | 0.12             | 215,662                                    | 9,722,482                           | 8,844                                   | 9,912                                  | 1,068                          |
| Targa 1                       | 189,457   | 41.5              | 291,000                  | 5                    | 46.5             | 326,000                  | 0.12             | 215,662                                    | 9,722,482                           | 4,202                                   | 4,708                                  | 505                            |
| Targa 2                       | 157,725   | 41.5              | 242,000                  | 5                    | 46.5             | 272,000                  | 0.12             | 215,662                                    | 9,722,482                           | 3,499                                   | 3,932                                  | 434                            |
| Targa 4                       | 334,904   | 41.5              | 515,000                  | 5                    | 46.5             | 577,000                  | 0.12             | 215,662                                    | 9,722,482                           | 7,429                                   | 8,323                                  | 894                            |
| Targa 5                       | 472,252   | 41.5              | 726,000                  | 5                    | 46.5             | 813,000                  | 0.12             | 215,662                                    | 9,722,482                           | 10,475                                  | 11,731                                 | 1,255                          |
| City Dock 16                  | 36,816    | 36.5              | 50,000                   | 1                    | 37.5             | 51,000                   | 0.02             | 114,078                                    | 4,916,674                           | 854                                     | 871                                    | 17                             |

Table 5-16: LSF Non-Federal Shoaling Summary (21 Benefiting Docks)

|   | LOCATION                    | FWOP<br>USACE*<br>CY/YR | FWP<br>INCR.<br>CY/YR | FWP<br>TOTAL<br>(CY/YR) |
|---|-----------------------------|-------------------------|-----------------------|-------------------------|
| 4 | Boggy Bayou to Greens Bayou | 0                       | 22,230                | 22,230                  |
|   | Greens Bayou to Sims Bayou  | 1,709                   | 6,418                 | 8,127                   |
| 6 | I-610 to Main TB            | 34,115                  | 17                    | 34,132                  |

\*USACE FWOP Non-Federal shoaling rate for affected reach

## 5.2.6 Channel Improvements Potential Effects on Existing and Planned Structures

### 5.2.6.1 Segment 1

The channel widening features in Segment 1 from Bolivar to Redfish and Redfish to BSC do not affect any existing or planned dock structures. In the BSC to BCC Reach, the channel widening modification/improvements will affect the shoreline at Morgans Point between Station 0+000 and 0+400. A sheet pile wall will be installed as discussed in Section 4.6. The main bridges that cross Segment 1 are the Fred Hartman & BW8), the air draft is 175 ft. The largest ships will transit under these two bridges are Aframax and Suezmax, which have max height above mast (sticking out of the water) under lightship condition of about 47.5 m to 48.5 (~156-159 ft) and less under normal ballast (~43 to 45m or 141-148 ft). The vessel size does not change.

### 5.2.6.2 Segment 2

Channel improvements on the BSC will not affect existing dock structures. The current dock setbacks are 225 feet from the dock face to the toe of the BSC. The dock facilities constructed and or planned contemplate a minimum design depth of 50 feet at the PHA BSC Container terminal, Odjfel and ITC. Channel widening will affect the north shore of the BSC as discussed in Section 4.6. Installation of sheet pile wall and relocation of the rock revetment are accounted for in the project costs and slope stability analysis using existing survey and geotechnical data is included as Attachment 5 of this Appendix.

### 5.2.6.3 Segment 3

Channel improvements on the BSC will not affect existing dock structures. The current dock setbacks are 225 feet from the dock face to the toe of the BSC. The dock facilities constructed and or currently being upgraded contemplate a minimum design depth of 50 feet at the PHA BCCT, and Enterprise. The LASH dock and RO/RO dock has been removed. Channel widening will affect the north shore of the BCC along Spilmans Island as discussed in Section 4.6. Installation of sheet pile wall and relocation of the rock revetment are accounted for in the project costs and slope stability analysis using existing survey and geotechnical data is included as Attachment 5 of this Appendix.



#### 5.2.6.4 Segment 4

Measure, **CW4\_BB-GB\_530**, would widen the channel up to 530 feet from Boggy Bayou to Greens Bayou (Station 684+00 to 833+00) and deepen to a depth of -46.5 feet MLLW to Hunting Turning Basin at Station 930+00 as shown in Figure 4-9.

Several measures were taken to communicate and obtain information from the LSFs, particularly in the widening sections of Segment 4 and include public notices, public meetings, presentation to Waterways Utilization and Navigation Operations subcommittees of the Lone Star Harbor Safety Committee, coordination with HP, phone interviews by the PHA, and coordination with the engineers of record. On June 6, 2018, a meeting was held with several of the LSF representatives for Texas Deepwater/Pinto Lion, Magellan, ITC, Contanda, Inneos Phenol and Kinder Morgan.

This coordination indicates that the widening of the channel should occur on centerline shifts to the north and south allowing for required setbacks from the docks/berthing facilities. Representatives of the Texas Deepwater project expressed concerns with options to focus widening to the north. All others were taking the deepening and widening into account for their planned construction. This coordination also indicated that the Hunting Bayou Turning basin is of sufficient size and does not need improvement other than deepening. The planned new facilities have incorporated vessel turning into their dock designs.

Close and regular coordination during PED between the USACE, the non-Federal Sponsor, HP, and the LSFs must occur to ensure that the Federal interests and construction of the LSFs are aligned. Improvements to the existing facilities and new facilities are occurring in the FWOP condition and therefore no costs for actual dock construction other than dredging to the deepened depth of -46.5 feet MLLW are included in the associated costs.

The existing BW8 Bridge is located at the beginning of this reach and a new bridge is currently under construction. The footings for the new bridge are outside of the planned channel improvements and the bridge clearance is sufficient for the planned vessel traffic. The existing bridge and its respective footings will be removed by the Harris County Transit Authority by 2020.

#### 5.2.6.5 Segment 5

This short section of channel scours and for the majority of the reach it is already at the proposed depth as shown by the relatively minimal amount of new work dredging in this reach. Therefore, no impacts to existing facilities is contemplated. The 610 Bridge lies between Segments 5 and 6 with a clearance of 135 feet. The vessel sizes in the economic analysis do not change and currently have this limitation in the FWOP condition.

#### **5.2.6.6 Segment 6**

The facilities directly adjacent to the channel improvements other than the Brady Island Turning Basin are PHA City docks. The majority of these docks were constructed in the 1950s and are undergoing refurbishment or replacement as part of the PHA Master Plan in the FWOP condition. Therefore, other than costs to deepen them, no other associated costs are estimated. Sheet pile wall will be installed as described in Section 4.6 at the Brady Island Turning Basin improvements.

## 6 GEOTECHNICAL

---

All geotechnical data collected to date within Galveston Bay was reviewed to determine its relevance to the current project and to identify what new investigations would be necessary for project design. Existing borings are included in the Engineering Plates.

### 6.1 Existing Borings

A majority of the historical geotechnical data was collected between 1963 and 1993 and published in the HGNC LRR in November 1995. This included channel boring series 3ST, 72 and 93. The plans for HGNC 46.5-foot project published between 1998 and 2002 for various sections of the channel utilized most all the geotechnical data from the HGNC LRR and was supplemented with new borings during construction. In many instances, errors were found in the boring logs of the HGNC LRR, but had been corrected in the HGNC 46.5-foot project construction plans. Based on the observed revisions, plans for the HGNC 46.5-foot project were used as the main source for historical boring locations. For any boring that did not have a location identified in the logs, their approximate location was determined from the boring plan view sheet. An image of the plan view was aligned as best possible over existing channel lines and PA dikes and a point created at each boring location.

Geotechnical data in the Upper Bayou section of the HSC, from Station 700+00 to 1082+50 were collected from the Texas Coastal Sediments Geodatabase compiled by the Texas General Land Office (GLO). HSC channel borings were collected in 1963, Greens Bayou borings in 1967 and Brady Island borings in 1964 and 1976. All borings designated with prefix 3ST and were collected by the USACE. The boring logs downloaded from the GLO are handwritten and do not provide a station and range, however a Latitude and Longitude is identified for each data point in the map viewer. How the GLO determined the location of these data points is unknown and their location should be considered approximate.

No geotechnical data within the existing or proposed channel limits could be found between HSC Station 1082+50 and the end of the Main Turning Basin at Station 30+95.06. To aid with the new work dredge material classification in Segments 5 and 6, the PHA provided geotechnical data from borings collected along numerous dock facilities between 1961 and 2000; which were collected as part of dock facilities expansion and/or modification projects.

#### 6.1.1 Segment 1: Bay Reach

Boring series 3ST, 72 and 93 run the extent of the channel segment starting at Bay Station 138+369.011 up through -0+003.944 and continuing through the Bayou from Station 0+05 to 684+03.19. The 3ST-series of borings were taken on an average 1,000-foot spacing, alternating between right and left sides of the channel. The 72 and 93-series of borings fill in the data gaps

between the 3ST-series. As channel modifications and PA development continued project specific borings were acquired and include the following borings in Segment 1:

- 1992 (SC-series) Bay Station 5+000 - 25+000
- 1998 (AM-series) Bay Station 1+000 - 29+000
- 1998 (LB-series) Bay Station 79+000 - 120+000
- 2000 (MB-series) Bay Station 34+000 - 75+000
- 2001 (B-series) Bay Station 35+000 - 75+000
- 2001 (SJ01, GI01, LB01, BM01, and B-series) Bayou Station 360+00 - 470+00
- 2009 (HSC-09-series) Bay Station 15+000 - 38+000

### **6.1.2 Segment 2: Bayport Ship Channel**

With every modification to the BSC there have been several rounds of geotechnical investigations. Borings within the footprints of the alternatives under review include the 1999 (B-series), 2000 (BF-series), 2004 (MB-series), 2009 (BC-series), and 2012 (12-series).

### **6.1.3 Segment 3: Barbours Cut Channel**

The most recent borings at the BCC labeled with the prefix L, S and T were taken in 2012 for the widening and deepening project that was completed in 2015. The 04-series of borings was taken in 2006.

### **6.1.4 Segment 4: Boggy Bayou to Sims Bayou**

The existing geotechnical data in this segment of the channel are the 3ST and 72-series borings taken prior to the 46.5-foot project. No existing geotechnical data was located above Station 1090+00.

### **6.1.5 Segment 5: Sims Bayou to I-610 Bridge**

No existing geotechnical data was available within the existing channel limits. Borings collected in 2000 from dock facilities were provided by the PHA.

### **6.1.6 Segment 6: I-610 Bridge to Turning Basin**

No existing geotechnical data was available within the existing channel limits. A series of borings were taken in the Brady Island Channel in 1964 that include one boring within the existing Brady Island Turning Basin. The PHA provided boring logs from samples collected along dock facilities between 1961 and 1969.

## 6.2 Future investigations/recommendation

Most of the HSC, BSC and BCC have ample existing geotechnical data that will be sufficient for material classification required at this stage of the study. Portions of the Bayou in Segments 4, 5, and 6, however, are lacking adequate geotechnical data. When determining where new geotechnical data is needed, the age of existing data, the depths to which the borings were taken and the footprint of the proposed alternatives were all factored in to the decision. Additional geotechnical data may be gathered through any or a combination of geotechnical borings, probings, acoustic subbottom profiling and other remote sensing surveys.

### 6.2.1 Segment 1: Bay Reach

This segment of the channel has an existing boring approximately every 1,000 feet or less, from 1963 through 2009. Existing data in this area should be sufficient for channel material classification for this stage of the study, however final engineering and design may require additional borings to be taken outside the existing channel toes to bolster the classification of new work dredge materials as much of the boring data is from 1963 to 2009.

For the associated PAs, borings shall be taken approximately every 500-1,000 feet along the dike and bird island alignments as well as borings representative of the interior to determine slope stability, foundation characteristics, settlement, and consolidation. Soft sediments are expected to be encountered and probings should also be taken to differentiate between soft soil layers.

Geotechnical hand and/or jet probing is a useful supplement to traditional geotechnical sampling in the aquatic environment and can be performed at a fraction of the cost of traditional geotechnical sample collection. Hand/jet probing should not be confused with other standardized probing methods such as Dynamic Probing (ISO 22476-2). Hand/jet probing is the practice of physically exploring substrate for determination of general material properties to a refusal stratum. No sample data for analysis or standardized strength test data is acquired. Both hand and jet probing involve lowering a graduated pipe to the bay bottom and pushing it through the substrate to determine material types through resistance and vibrations against the pipe. In both types, an auger is generally attached at the end of the pipe to assist with transitioning between sediment layers. Hand probing typically employs a ¾" galvanized steel pipe as shown in Figure 6-1. They are very useful in shallow water and can be done aboard a small vessel. Jet



Figure 6-1: Hand Probing



Figure 6-2: Jet Probing

probing is similar with the addition of using a hose mounted water supply at the top of the pipe. This allows washing of the probing hole for increased depth measurements. Jet probes use a larger diameter rod (typically 1½ inch aluminum) and are performed aboard a larger vessel or drilling rig capable of supplying the water and raising the pipe. Typical probing data can be extremely useful for determining weight-of-rod material, soft clay, sand and shell layers, and a refusal layer, relating that information into foundation design. Refusal represents the stratum of resistant bearing or shear and for most areas usually represents thick oyster reef, medium to stiff clays, or densely packed sand.

Navigation is typically performed with consumer grade GPS equipment; however tighter accuracy can be warranted. In dredging projects, probing data is used in order to supplement the traditional geotechnical data in between boring locations, and primarily to develop a spatial model of soft bay bottom sediments.

The strata to be determined are classified vertically to quantify the varying material types and to identify potential habitat impacts and soft foundations, at a minimum. A trained engineer, scientist, surveyor, or technician can perform probings and determine material types through resistance, touch, and sound. The probing pipe can also be turned at refusal to obtain a short plug sample of material on the auger tip for visual classification.

Probing data is processed, and tide corrected at each location. The data is plotted onto probing logs with locational information, and the vertical profile of layers observed. With this information, composite data sets can be created with surface linkage for volumetric analysis. A typical jet probing log is provided in Figure 6-3.

| Probing Logs               |                        |                                 |                |
|----------------------------|------------------------|---------------------------------|----------------|
| <b>Project:</b>            | BAYPORT                | <b>Driller:</b>                 | KINDLE         |
| <b>Location:</b>           | M789                   | <b>Engineer:</b>                | MIKE           |
| <b>Vessel:</b>             |                        | <b>Boat Operator:</b>           | ASHTON         |
|                            |                        | <b>Position Equip:</b>          | 2" HONDA GX120 |
| <hr/>                      |                        |                                 |                |
| <b>Date:</b>               | 9/16/2009              | <b>Easting:</b>                 | 3259116.090    |
|                            |                        | <b>Northing:</b>                | 13796529.180   |
| <b>Hole Number:</b>        | W7                     | <b>Station:</b>                 | <b>Range:</b>  |
| <b>Time:</b>               | 11:14:00               |                                 |                |
| <b>Sounding Depth:</b>     | 7. ft.                 | <b>Bottom of Probe:</b>         | 28. ft.        |
|                            |                        | <b>Penetration:</b>             | 21. ft.        |
| <b>Depth, ft.</b>          | <b>Elevation (ft):</b> | <b>Bottom Character:</b>        |                |
| 7.0 - 17.0                 | : -17.0                | WOR                             |                |
| 17.0 - 20.0                | : -17.0                | MED. SAND AND SHELL (high pump) |                |
| 20.0 - 24.0                | : -20.0                | SILTY CLAY                      |                |
| 24.0 - 27.0                | : -24.0                | FIRM CLAY                       |                |
| 27.0 - 28.0                | : -27.0                | VERY FIRM CLAY                  |                |
| 28.0 -                     | : -28.0                | REFUSAL                         |                |
|                            | :                      |                                 |                |
|                            | :                      |                                 |                |
|                            | :                      |                                 |                |
| <b>Character of Finish</b> | : VERY FIRM CLAY       | <b>Tide (MLT):</b>              | . ft.          |

Figure 6-3: Typical Probing Field Log

### 6.2.2 Segment 2: Bayport Ship Channel

There is currently sufficient existing geotechnical data from within the BSC alternatives to classify dredge materials. Final engineering and design could benefit from additional borings to fill gaps in the data for the flare widening as shown in Figure 6-4. Additionally, more borings may be needed during PED to validate slope stability and sheet pile wall requirements along the north slope of the BSC within the land cut. For the associated PAs, borings shall be taken approximately every 500-1,000 feet along the dike and bird island alignments, and include several borings within the interior of the site. The geotechnical data will be used to determine slope stability, foundation characteristics, settlement, and consolidation required for site design.

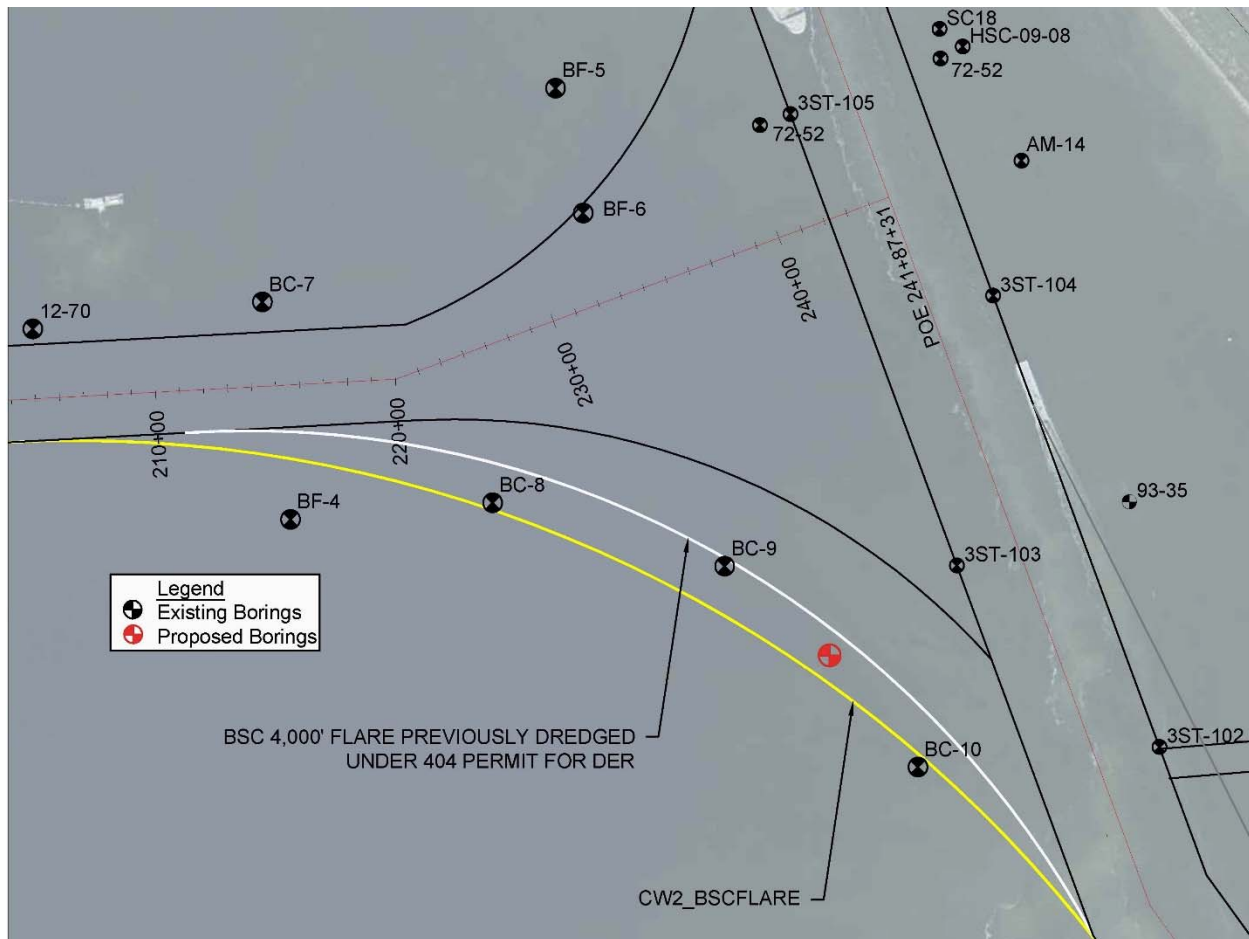

Figure 6-4: Proposed borings for CW2\_BSCFlare

### 6.2.3 Segment 3: Barbours Cut Channel

There is currently sufficient existing geotechnical data from within the BCC alternatives to classify dredge materials. Final engineering and design could benefit from additional borings for the 1,800-foot BCC flare modification. Proposed boring locations are provided in Figure 6-5. Three borings in the south flare region, and two additional borings in the north flare are recommended to



be taken during the PED phase. Additionally, more borings may be needed during PED to validate slope stability and sheet pile wall requirements along the south side of Spilmans Island. For the associated PAs, borings shall be taken approximately every 500-1,000 feet along the dike and bird island alignments and include several borings within the interior of the site.

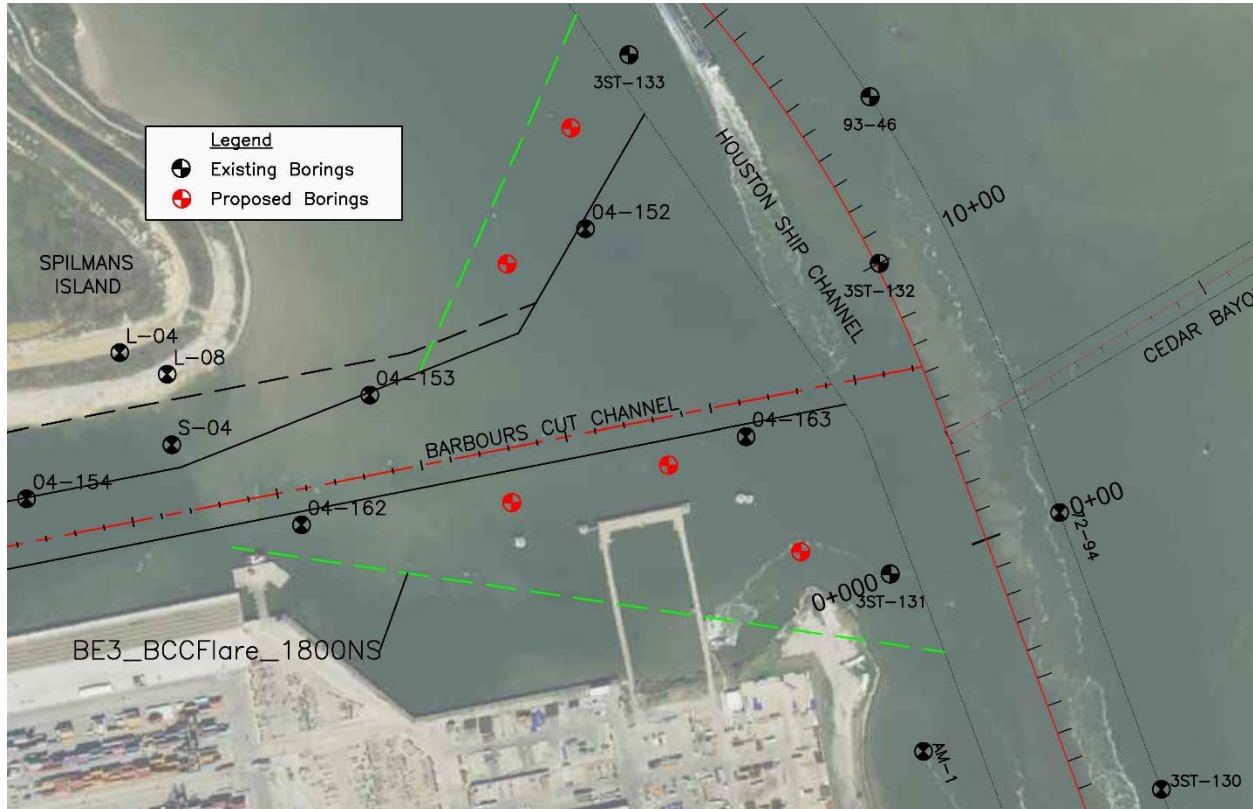

Figure 6-5: Proposed borings for BCC 1,800-foot Flare Easing and Turning Basin (BETB3\_BCCFlare\_1800NS)

#### 6.2.4 Segment 4: Boggy Bayou to Sims Bayou

The existing geotechnical data in this segment of the channel is sparse, consisting of 3ST and 72-series borings. All 3ST borings in this section of the channel are from the Texas Coastal Sediments Geodatabase. Segment 4 includes a combination of widening and deepening from Boggy Bayou to Sims Bayou. The existing borings were used to classify materials, however new borings would be required for final engineering and design. It is recommended that new borings be taken every 1,000 feet along the proposed channel toe along alternating sides of the channel. This would result in 18 new borings in Segment 4. For PA sites BW-8 and E2C, borings shall be taken approximately every 500-1,000 feet along the dike alignment and include several borings within the interior of the sites.

### 6.2.5 Segment 5: Sims Bayou to I-610 Bridge

Geotechnical data collected from the dock facilities in 2000 was provided by the PHA and used to classify materials for the channel deepening in Segment 5. For final engineering and design, it is recommended that borings be acquired every 1,000 feet along the existing channel toe on alternating sides of the channel. This segment of the HSC is approximately 5,000 feet in length and would require 5 geotechnical borings. Borings shall be taken approximately every 500-1,000 feet along the dike alignment at E2C and include several borings within the interior of the site. Existing geotechnical data at Filterbed and Glendale will be used for preliminary assessment. Slope stability analysis on existing UCPAs was conducted during the HSCPA and are included in Attachment 7 in this Appendix.

### 6.2.6 Segment 6: I-610 Bridge to Turning Basin

Geotechnical data collected from the dock facilities between 1961 to 1969 was provided by the PHA and used to classify materials for the channel deepening in Segment 6. For final engineering and design, it is recommended that borings be acquired every 1,000 feet along the existing channel toe on alternating sides of the channel. This segment of the HSC is 13,700 feet in length and would require 14 geotechnical borings. Existing geotechnical data at Filterbed and Glendale will be used for preliminary assessment. Slope stability analysis on existing UCPAs was conducted during the HSCPA and are included in Attachment 7 in this Appendix.

## 6.3 New Work Materials

Historical boring logs were reviewed to determine the material types in accordance with Unified Soil Classification (ASTM D-2487-98) and categorize them into: Very Soft Silts & Clays, Soft Silts & Clays, Medium Clays, Stiff Clays, Very Stiff Clays, Hard Clays, Loose Sands, Medium Dense Sands, Very Dense Sands, and Medium to Dense Silt. Table 6-1 is provided to establish a point of reference for the categorization of the materials.

Table 6-1: Categorization of materials based on their consistency or relative density

| Relative Density of Sand            |                  | Strength of Clay                    |   |             |
|-------------------------------------|------------------|-------------------------------------|---|-------------|
| Penetration Resistance N (blows/ft) | Relative Density | Penetration Resistance N (blows/ft) | Unconfined Compressive Strength (tons/ft <sup>2</sup> ) | Consistency |
| 0-4                                 | Very loose       | <2                                  | <0.25   | Verysoft    |
| 4-10                                | Loose            | 2-4                                 | 0.25-0.50   | Soft        |
| 10-30                               | Medium           | 4-8                                 | 0.50-1.00   | Medium      |
| 30-50                               | Dense            | 8-15                                | 1.00-2.00   | Stiff       |
| >50                                 | Very dense       | 15-30                               | 2.00-4.00   | Very stiff  |
|                                     |                  | >30                                 | >4.00   | Hard        |

From Terzaghi and Peck, 1948 (Source: Soil Mechanics, T.W. Lambe và R.V. Whitman)

It should be noted that these material estimates are based on historic borings ranging from one to several decades old. Material types may additionally vary between the boring locations where data has been linearly interpolated. Additional information as collected and/or received may warrant revision of the material types and quantities provided herein.

Materials were then plotted in profile along the dredging reach and connected between like material types. Figure 6-6 through Figure 6-12 are plan-profile drawings identifying the historical borings used and the material profiles created therefrom. After generating the profiles, material layers were created in Trimble Terramodel v10.61 and material volumes by type were generated. Reaches are presented proceeding from south to north.



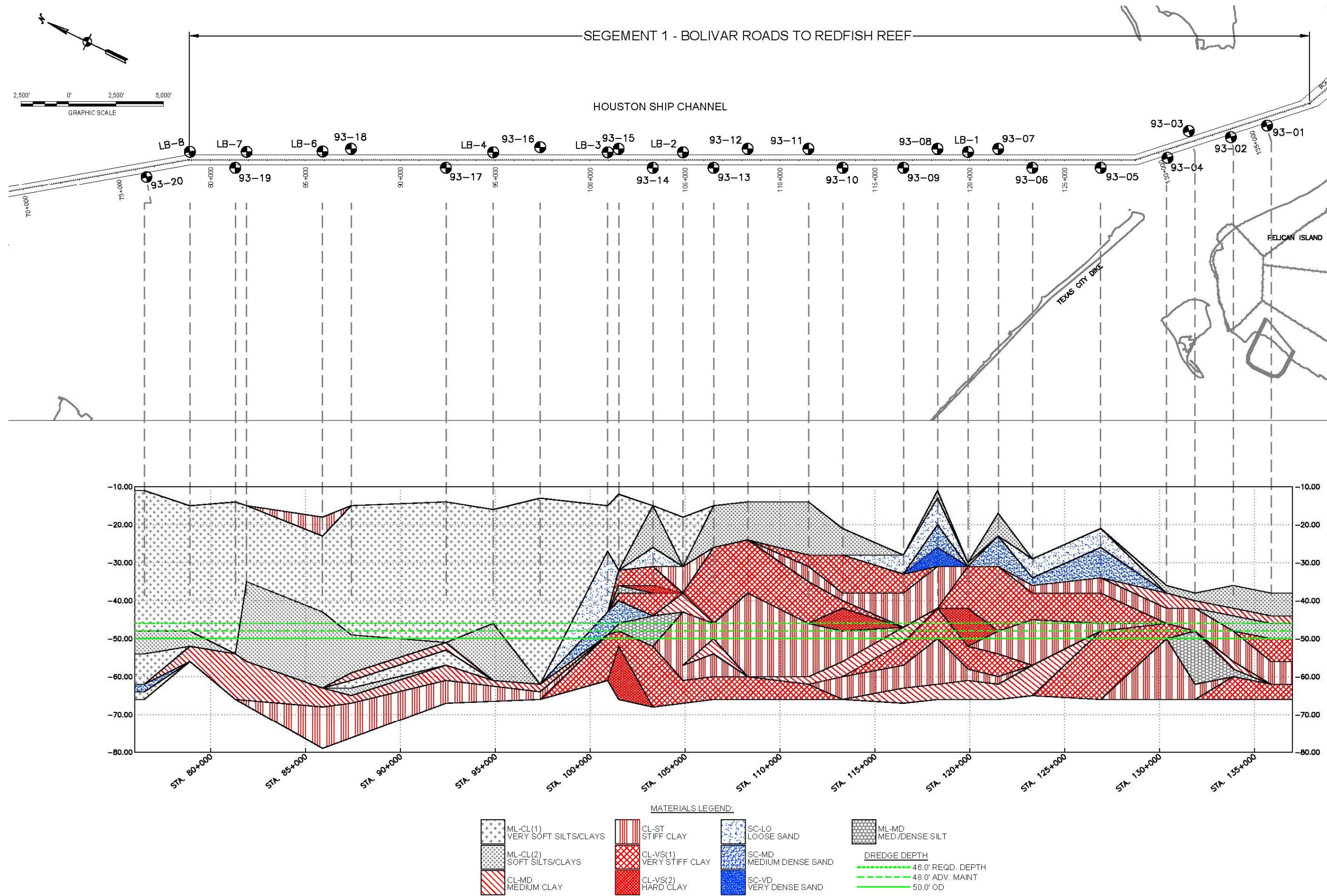
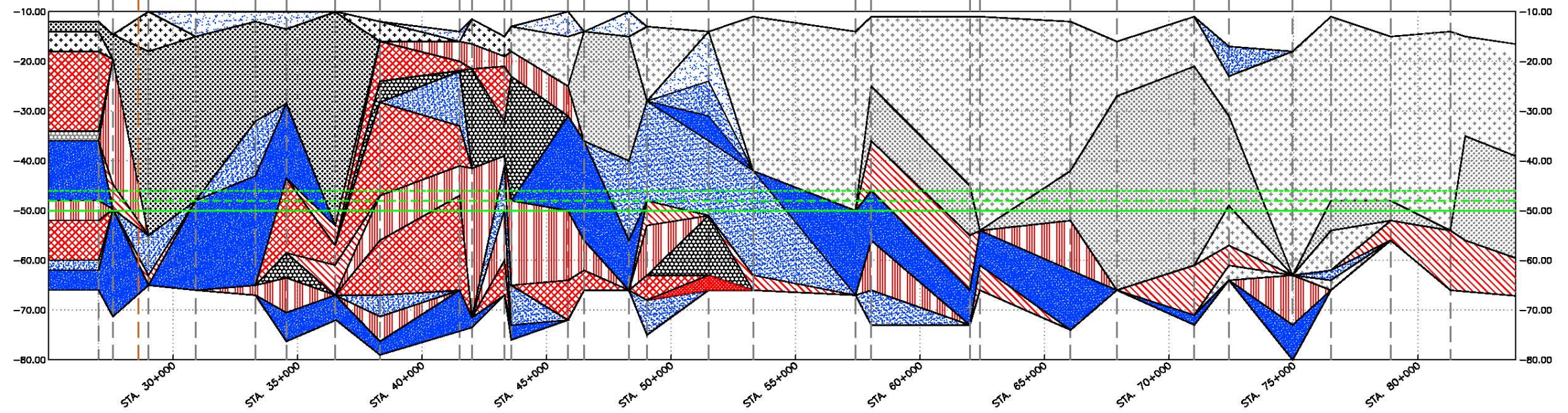
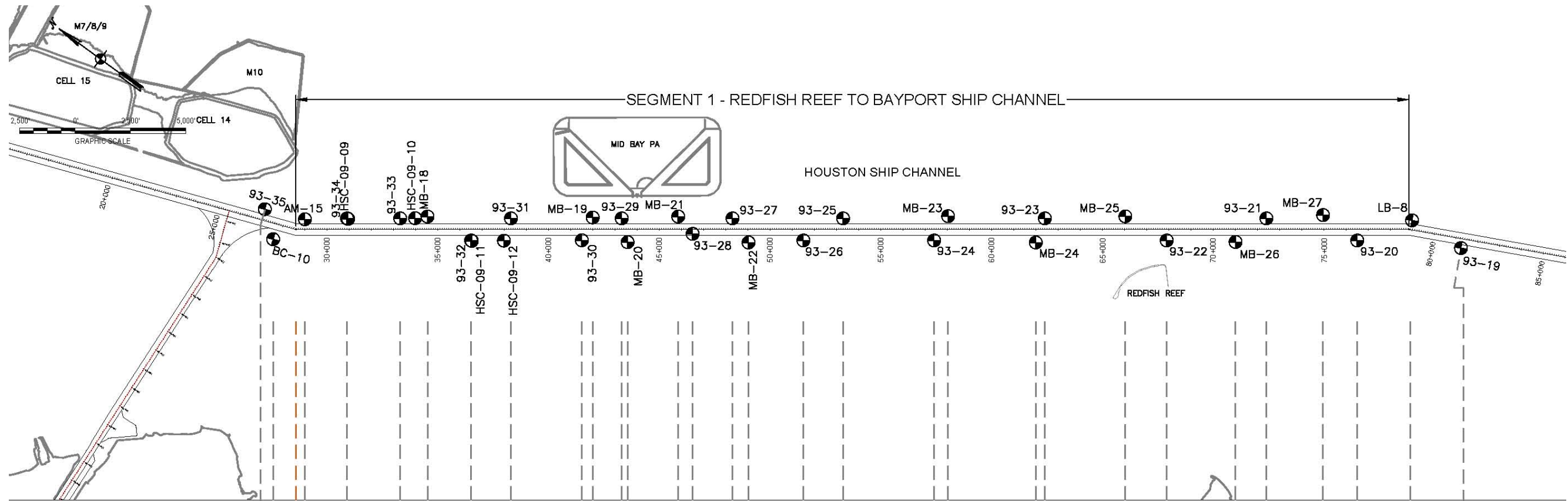

Figure 6-6: Geotechnical Profile Segment 1 - Lower Bay  
HSC-ECIP Engineering Appendix C





**MATERIALS LEGEND**

|                                   |                             |                            |                         |
|-----------------------------------|-----------------------------|----------------------------|-------------------------|
| ML-CL(1)<br>VERY SOFT SILTS/CLAYS | CL-ST<br>STIFF CLAY         | SC-LO<br>LOOSE SAND        | ML-MD<br>MED/DENSE SILT |
| ML-CL(2)<br>SOFT SILTS/CLAYS      | CL-VS(1)<br>VERY STIFF CLAY | SC-MD<br>MEDIUM DENSE SAND |                         |
| CL-MD<br>MEDIUM CLAY              | CL-VS(2)<br>HARD CLAY       | SC-VD<br>VERY DENSE SAND   |                         |

**DREDGE DEPTH**

|  |                    |
|--|--------------------|
|  | 46.5' REQ'D. DEPTH |
|  | 48.5' ADV. MAINT.  |
|  | 50.5' OD           |

Figure 6-8: Geotechnical Profile Segment 1 - Mid Bay  
HSC-ECIP Engineering Appendix C



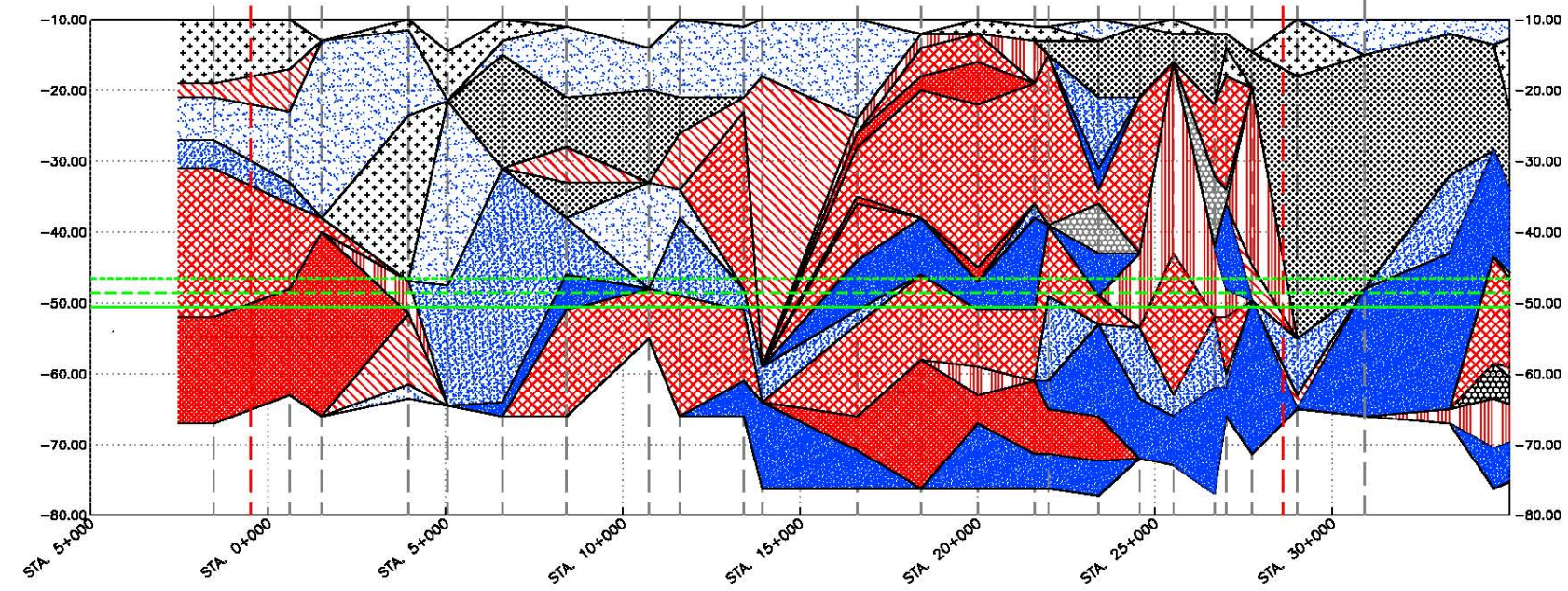
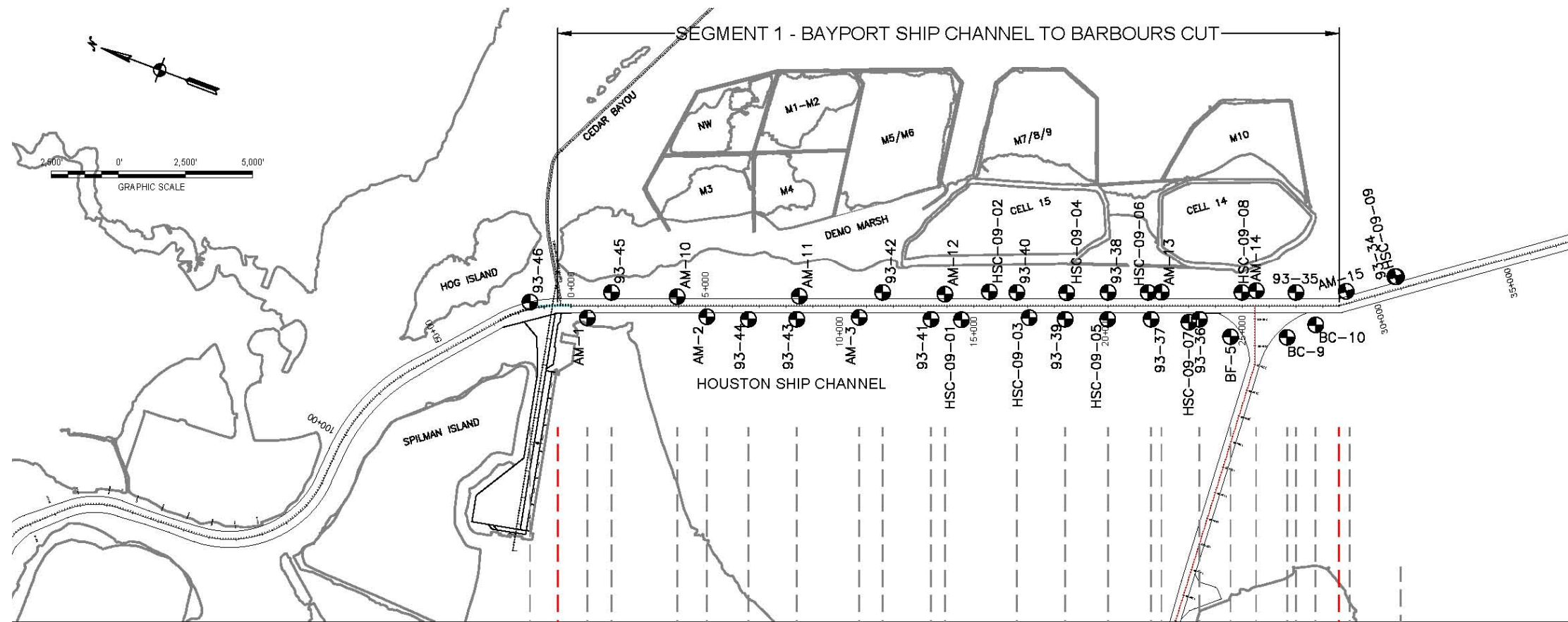

MATERIALS LEGEND:

|                                   |                             |                            |                         |
|-----------------------------------|-----------------------------|----------------------------|-------------------------|
| ML-CL(1)<br>VERY SOFT SILTS/CLAYS | CL-ST<br>STIFF CLAY         | SC-L0<br>LOOSE SAND        | ML-MD<br>MED/DENSE SILT |
| ML-CL(2)<br>SOFT SILTS/CLAYS      | CL-VS(1)<br>VERY STIFF CLAY | SC-MD<br>MEDIUM DENSE SAND |                         |
| CL-MD<br>MEDIUM CLAY              | CL-VS(2)<br>HARD CLAY       | SC-VD<br>VERY DENSE SAND   |                         |

DREDGE DEPTH

- 46.5' REQD. DEPTH
- 48.5' ADV. MAINT
- 50.5' OD

Figure 6-9: Geotechnical Profile Segment 1 - Upper Bay  
HSC-ECIP Engineering Appendix C



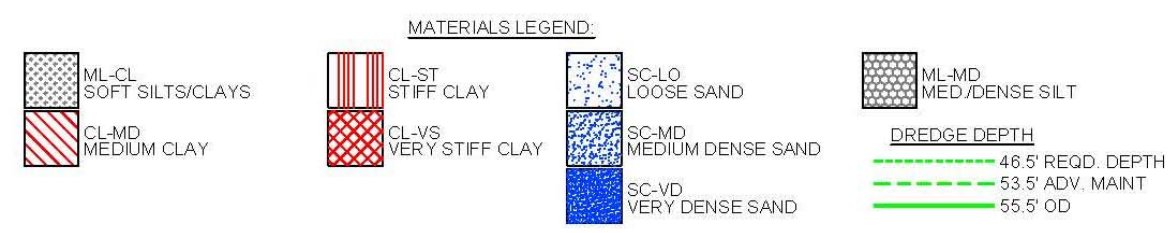
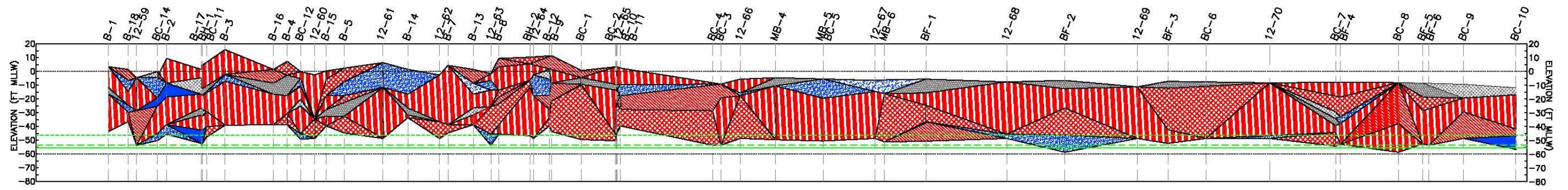
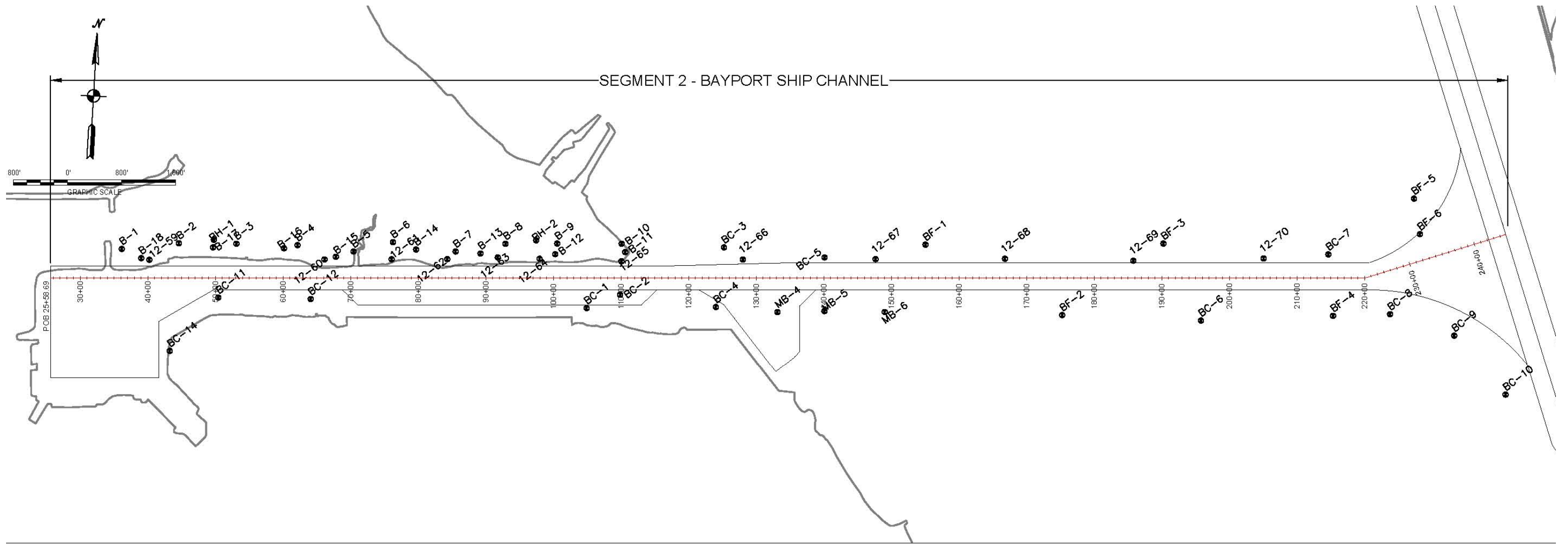
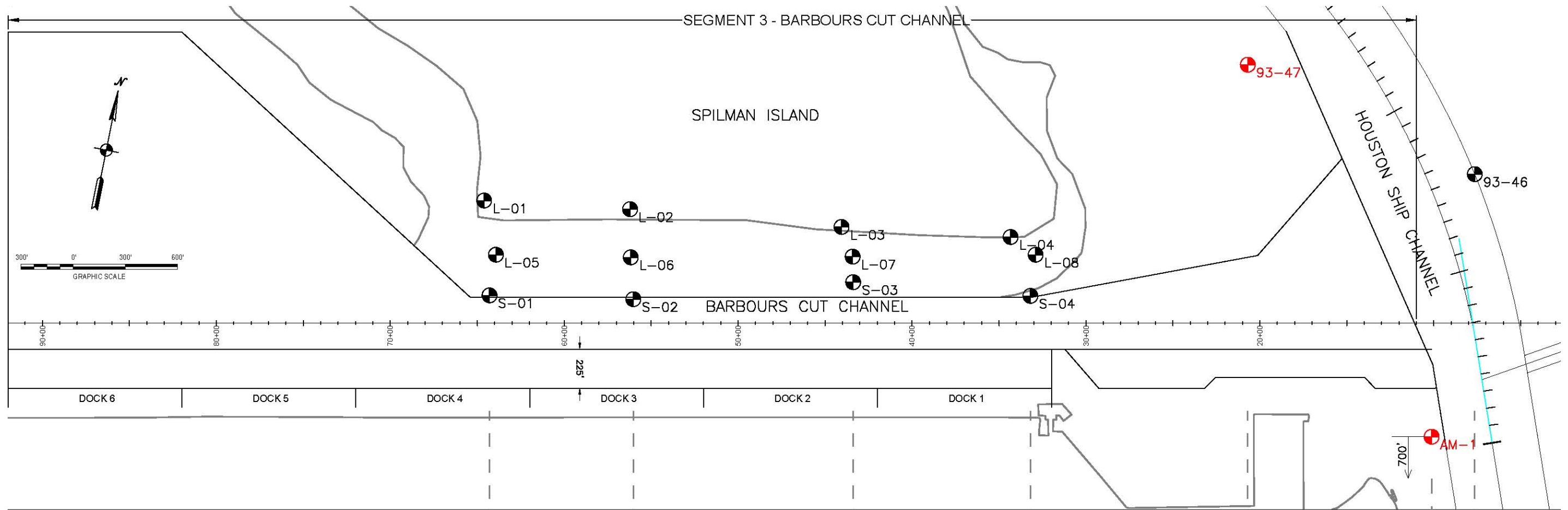

Figure 6-10: Geotechnical Profile Segment 2  
HSC-ECIP Engineering Appendix C





**MATERIALS LEGEND:**

- ML-CL(1)  
VERY SOFT SILTS/CLAYS
- ML-CL(2)  
SOFT SILTS/CLAYS
- CL-MD  
MEDIUM CLAY
- CL-ST  
STIFF CLAY
- CL-VS(1)  
VERY STIFF CLAY
- CL-VS(2)  
HARD CLAY
- SC-LO  
LOOSE SAND
- SC-MD  
MEDIUM DENSE SAND
- SC-VD  
VERY DENSE SAND
- ML-MD  
MED./DENSE SILT

- DREDGE DEPTH**
- 46.5' REQD. DEPTH
  - 53.5' ADV. MAINT
  - 55.5' OD

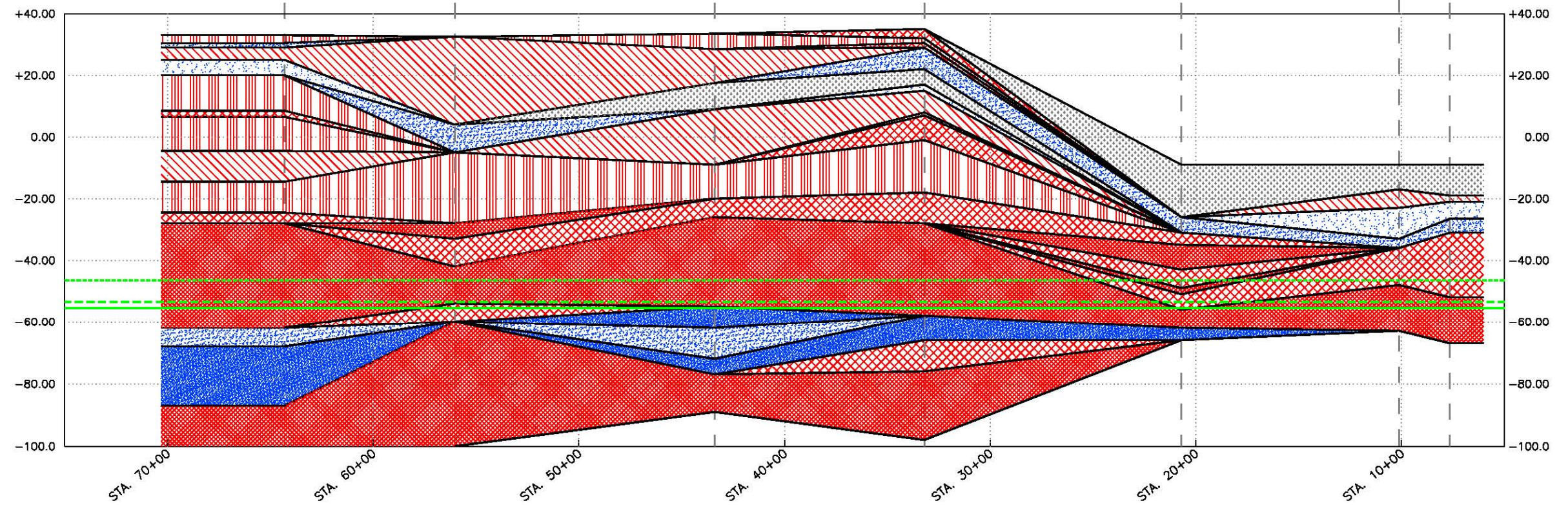

Figure 6-11: Geotechnical Profile Segment 3



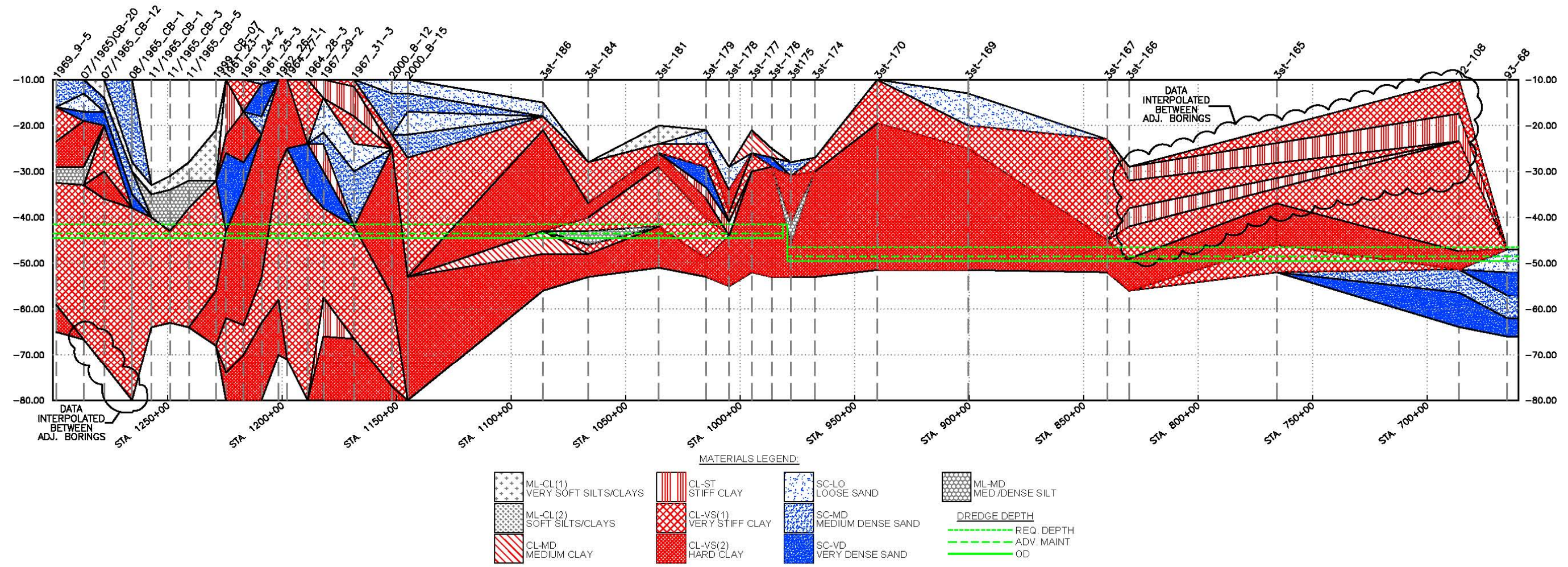
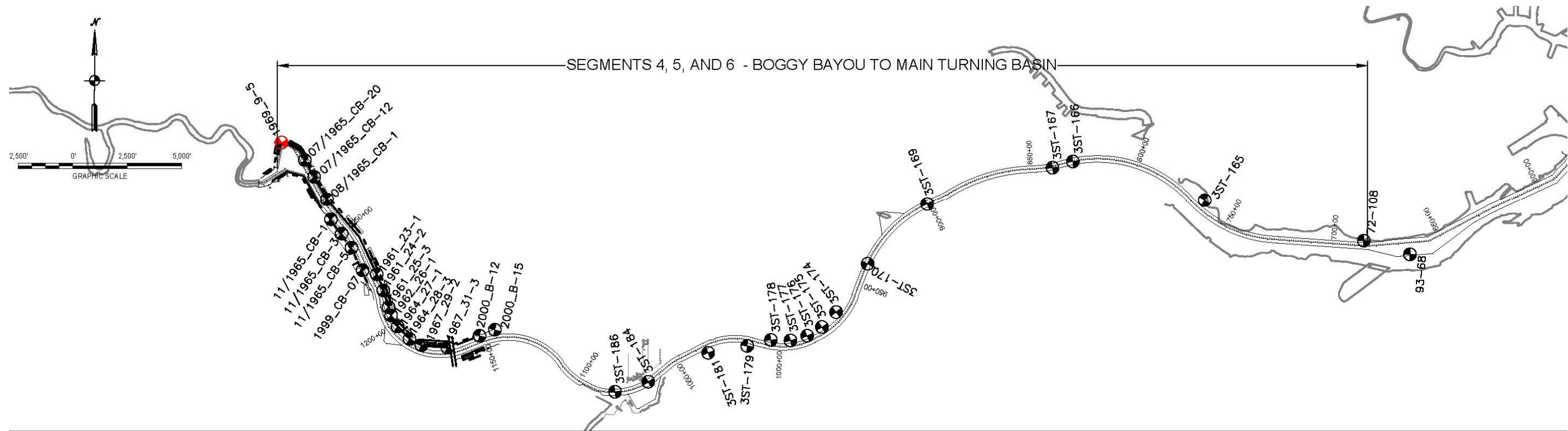

Figure 6-12: Geotechnical Profile Segment 4, 5, & 6  
HSC-ECIP Engineering Appendix C



Table 6-2: HSC-ECIP NW Material Classification

| Material Type             | Segment 1 - CW1_BR-Redfish_700 (w/ Bends)           |             | Segment 1 - CW1_Redfish-BSC_700 (w/Bends) |             | Segment 1 CW1_BSC-BCC_700 (w/Bends)  |             | Segment 2 CW2_BSC_455        |                | Segment 2 BE2_BSCFlare              |                | Segment 3 CW3_BCC_455 & BETB3_BCCFlare_1800         |                | Segment 4 CW4_BB-GB_530 & CD4_Whole                       |                | Segment 5 CD5_Whole  |                | Segment 6 CD6_Whole                |                |
|---------------------------|---|-------------|---|-------------|--------------------------------------|-------------|------------------------------|----------------|-------------------------------------|----------------|---|----------------|---|----------------|--|----------------|------------------------------------|----------------|
|                           | Bolivar to Redfish Reef (Station 138+369 to 78+844) |             | Redfish to BSC (Station 78+844 to 28+605) |             | BSC to BCC (Station 28+604 to -3.94) |             | BSC (Station 25+58 – 222+76) |                | BSC Flare (Station 203+66 – 239+78) |                | BCC + BETB3_BCCFlare_1800NS (Station 8+78 to 67+11) |                | Boggy Bayou to Sims Bayou (Station 684+03.19 – 974+07.50) |                | Sims Bayou to I-610 Bridge (Station 1110+77.54 – 1160+62.20) |                | I-610 Bridge to Main Turning Basin |                |
|                           | Quantity (CY)                                       | % of Total  | Quantity (CY)                             | % of Total  | Quantity (CY)                        | % of Total  | Quantity (CY)                | % of Total     | Quantity (CY)                       | % of Total     | Quantity (CY)                                       | % of Total     | Quantity (CY)   | % of Total     | Quantity (CY)  | % of Total     | Quantity (CY)                      | % of Total     |
| Very Soft Silts & Clays   | 1,637,380   | 41.75%      | 3,261,691                                 | 37.09%      | 488,605                              | 9.15%       | 104,559                      | 4.96%          | 95,469                              | 4.96%          | 38,935  | 1.38%          | 434,108   | 12.47%         | 3  | 0.00%          | 818                                | 0.08%          |
| Soft Silts & Clays        | 415,493   | 10.59%      | 2,712,865                                 | 30.85%      | 604,469                              | 11.32%      | -                            | -              | -                                   | -              | 117,654   | 4.16%          | -   | -              | -  | -              | -                                  | -              |
| Medium Clays              | 80,040  | 2.04%       | 165,984                                   | 1.89%       | 454,281                              | 8.51%       | 120,983                      | 5.74%          | 110,464                             | 5.74%          | 200,561   | 7.10%          | 1,633   | 0.05%          | 11   | 0.01%          | 32                                 | 0.00%          |
| Stiff Clays               | 631,947   | 16.11%      | 339,280                                   | 3.86%       | 528,675                              | 9.90%       | 1,020,308                    | 48.39%         | 931,601                             | 48.39%         | 840,389   | 29.74%         | 322,369   | 9.26%          | 102  | 0.06%          | 2,555                              | 0.26%          |
| Very Stiff Clays          | 661,585   | 16.87%      | 463,883                                   | 5.28%       | 1,178,187                            | 22.06%      | 539,883                      | 25.61%         | 492,944                             | 25.61%         | 487,349   | 17.25%         | 1,306,549   | 37.53%         | 126,817  | 72.04%         | 804,661                            | 80.45%         |
| Hard Clays                | 94,061  | 2.40%       | 0   | 0.00%       | 211,612                              | 3.96%       | -                            | -              | -                                   | -              | 776,343   | 27.48%         | 1,405,108   | 40.36%         | 40,591   | 23.06%         | 126,559                            | 12.65%         |
| Loose Sands               | 148,818   | 3.79%       | 193,693                                   | 2.20%       | 891,624                              | 16.69%      | 56,843                       | 2.70%          | 51,901                              | 2.70%          | 146,458   | 5.18%          | 2,904   | 0.08%          | 2,393  | 1.36%          | 1,957                              | 0.20%          |
| Medium Dense Sands        | 157,293   | 4.01%       | 749,880                                   | 8.53%       | 509,163                              | 9.53%       | 170,273                      | 8.08%          | 155,469                             | 8.08%          | 217,696   | 7.71%          | 1,781   | 0.05%          | 6,029  | 3.42%          | 9,157                              | 0.92%          |
| Dense to Very Dense Sands | 414   | 0.01%       | 589,650                                   | 6.71%       | 406,245                              | 7.61%       | 8,360                        | 0.40%          | 7,633                               | 0.40%          | -   | -              | 3,360   | 0.10%          | 72   | 0.04%          | 21,519                             | 2.15%          |
| Medium to Dense Silts     | 95,101  | 2.42%       | 316,945                                   | 3.60%       | 68,081                               | 1.27%       | 87,277                       | 4.14%          | 79,689                              | 4.14%          | -   | -              | 3,504   | 0.10%          | 31   | 0.02%          | 32,943                             | 3.29%          |
| <b>Total NW</b>           | <b>3,922,130</b>                                    | <b>100%</b> | <b>8,793,872</b>                          | <b>100%</b> | <b>5,340,943</b>                     | <b>100%</b> | <b>2,108,485</b>             | <b>100.00%</b> | <b>1,925,170</b>                    | <b>100.00%</b> | <b>2,825,383</b>                                    | <b>100.00%</b> | <b>3,481,316</b>  | <b>100.00%</b> | <b>176,049</b>   | <b>100.00%</b> | <b>1,000,200</b>                   | <b>100.00%</b> |

*(This page left blank intentionally.)*

## 6.4 Maintenance Materials

Maintenance sediments encountered in the HSC consist of mixtures of clay, silt, and sand of varying percentages. Actual grain size for individual dredging operations will vary based on climate conditions such as tropical storms, drought, and floods. Results of historic particle size analyses for maintenance sediment grab samples obtained from the HSC and tributary channels shown in Table 6-3, indicate the percentage of fines (clay and silt particle sizes) ranges from about 43 percent to 91 percent (USACE, 2016a). The balance of the maintenance sediment consists of sand-sized or larger particles.

To calculate short term volumes of dredged materials and estimate capacity in UCPAs a bulking factor of 1.3 will be used for the HSC, BSC, and BCC and 1.1 for the Light Draft Channel. Shrinkage factors (for long term storage) of 0.65 will be used for the HSC, BSC, and BCC and 0.80 for the Light Draft Channel.

Table 6-3: Maintenance Material Sediment Grain Size

| Dredging Reach                    | Reach Length (feet) | Particle Size Distribution |                      |                      |                     |                              |
|-----------------------------------|---------------------|----------------------------|----------------------|----------------------|---------------------|------------------------------|
|                                   |                     | Average Percent Sand       | Average Percent Silt | Average Percent Clay | Percent Silt & Clay | Average D <sub>50</sub> (mm) |
| Bolivar Roads to Redfish Reef     | 59,525              | 56.0                       | 19.0                 | 25.0                 | 44.0                | 0.111                        |
| Redfish Reef to BSC               | 50,239              | 29.9                       | 34.4                 | 35.7                 | 70.1                | 0.048                        |
| BSC to Morgans Point (BCC)        | 28,609              | 22.1                       | 36.4                 | 41.5                 | 77.9                | 0.031                        |
| BSC                               | 21,610              | 21.4                       | 34.6                 | 44.0                 | 78.6                | 0.039                        |
| Morgans Point (BCC) to Exxon      | 29,500              | 20.4                       | 41.4                 | 38.2                 | 79.6                | 0.038                        |
| BCC                               | 8,432               | 9.0                        | 37.7                 | 53.3                 | 91.0                | 0.013                        |
| Exxon to Carpenters Bayou         | 22,500              | 18.7                       | 33.4                 | 47.9                 | 81.3                | 0.028                        |
| Carpenters Bayou to Greens Bayou  | 31,305              | 16.2                       | 39.5                 | 44.3                 | 83.8                | 0.018                        |
| Greens Bayou to Sims Bayou        | 27,772              | 17.1                       | 55.5                 | 27.4                 | 82.9                | 0.021                        |
| Greens Bayou Channel              | 10,824              | 33.0                       | 36.8                 | 30.2                 | 67.0                | 0.068                        |
| Sims Bayou to Upper Turning Basin | 15,572              | 21.4                       | 54.7                 | 23.9                 | 78.6                | 0.029                        |
| Brady Island Channel              | 5,875               | 23.6                       | 55.6                 | 20.8                 | 76.4                | 0.034                        |
| Buffalo Bayou Light Draft Channel | 21,610              | 57.5                       | 28.8                 | 13.7                 | 42.5                | 0.146                        |
| Turkey Bend Channel               | 4,026               | 50.6                       | 35.8                 | 13.6                 | 49.4                | 0.088                        |

*(This page left blank intentionally.)*

## **7 ENVIRONMENTAL CONSIDERATIONS**

---

### **7.1 Environmental Engineering**

#### **7.1.1 Design of Positive Environmental Attributes into the Project**

In citing new dredged material PAs, measures were taken to avoid impacting protected species and avoidance of wetlands and oyster habitat where feasible. If by chance oyster habitat or wetlands were impacted, they are mitigated. Environmental attributes of the project include increasing navigation efficiency and safety and beneficial use of dredge material for land reclamation, creation of bird islands and marshes.

#### **7.1.2 Inclusion Of Environmentally Beneficial Operations And Management For The Project**

O&M dredging of the newly created channel is an opportunity to positively benefit the environment. Dredging the channel and removing the sediment will reduce the risk of pilots moving off course. The O&M plan consisted of utilizing existing and newly created PAs.

#### **7.1.3 Maintenance Of Ecological Continuity In The Project With The Surrounding Area And Within The Region**

The ecological continuity in the project with the surrounding area and within the region should not be interrupted permanently with the current dredging and material placement plans.

#### **7.1.4 Consideration of Indirect Environmental Costs and Benefits**

Indirect environmental costs and benefits were considered in the preliminary layout of the proposed channel improvements and newly created PAs. The proposed measures were designed to avoid environmental habitats as much as possible. The water quality may be affected by turbidity and the exhaust from the dredge during construction and future maintenance may have a minor effect on the degradation of air quality. Improvements to the existing HSC-is not expected to significantly disrupt the environment. The proposed project does not impact Federally listed threatened or endangered species or their designated critical habitat.

#### **7.1.5 Integration of Environmental Sensitivity Into All Aspects Of The Project**

Consideration has been given to environmental, social and economic effects of proposed project modifications in accordance with NEPA in all aspects of the project.



### **7.1.6 Perusal Of The Environmental Review Guide For Operations With Respect To Environmental Problems At Similar Existing Projects.**

Lessons learned from similar projects by using the Environmental review Guide for Operations (ERGO) will be considered in this design. Environmental issues for this project will be addressed.

### **7.1.7 Incorporation of Environmental Compliance Measures Into The Project Design**

USACE Environmental Operating Principles (EOP) were incorporated into the project design. The EOP principles ensure conservation, environmental preservation and restoration. Coordination with the USFWS and the NMFS under the Endangered Species Act will be done, thereby removing risks of impacts to endangered species or their habitats.

## **7.2 Mitigation**

ER 1105-2-100 requires mitigation of significant unavoidable losses to significant ecological resources (USACE, 2000). Dredging to implement modifications to the channel for the TSP would result in removal of oyster reef and shell hash habitat that have been mapped within the project footprint. If not mitigated for, this would be a permanent impact to the local oyster reef habitat; however mitigation of these impacts will include restoration of healthy oyster reefs damaged by Hurricane Ike through construction of reef pads in Galveston Bay. Further details regarding mitigation is discussed in the Mitigation Plan provided in Appendix P.

## **7.3 Calculating Impacts to Mapped Oyster Reefs**

Prior to 2011, the most recent and comprehensive reef mapping data for Galveston Bay was from a study published in 1994 by Powell et al. Texas Parks and Wildlife Department (TPWD) updated the data in 2011 from Station 2+500 to 52+300. In September 2018, the JV conducted sidescan surveys of the HSC from Station -03.94 to 3+000 and 52+000 to 101+500 to the limits of the proposed 700-foot channel widening. Additional areas surveyed included the project footprint of the BETB3\_BCCFlare, and an 1,800-acre area between M10 and Mid Bay where BU areas may be constructed. The JV completed an oyster dredge survey to confirm and more accurately evaluate the results of the sidescan survey.

The 2011 TPWD data in was combined with the 2018 JV survey to create one layer of oyster habitat data. The footprint of each measure was overlaid on the data to calculate potential impacts from the proposed improvements. The optimum area for oyster growth along the HSC begins at the 20-foot depth contour and continues up the slope into shallower water (USACE, 1995). This depth was identified by resource agencies and used to determine impacts to oysters for the Galveston Bay Area Navigation Study for improvements to the HSC. Continuing with this assumption, boundaries for each channel widening measure were created using the 20-foot contour along the existing HSC and the point at which the widened channel daylighted with the existing bay

bottom. The 20-foot contour was originally in MLT and was converted to -21.31 feet MLLW to be consistent with the new project datum. These limits are identified in Figure 7-1. Where any reef boundary fell within the limits of potential impact the acreage was calculated and combined to estimate the total impact from each measure as provided in Table 7-1.

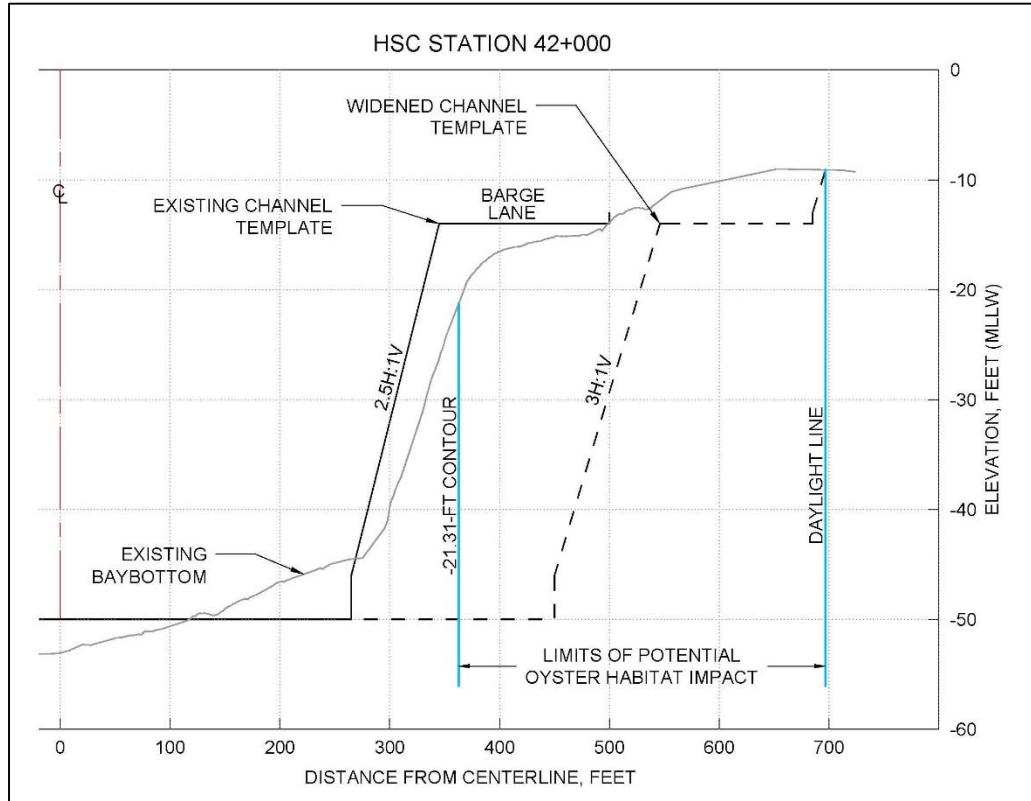

Figure 7-1: Potential Oyster Impact Limits

Table 7-1: Mitigation Requirements

| Category              | Project Component                 | Oyster Mitigation Required (Acres) | Bay Bottom Conversion Mitigation Required (Acres) |
|-----------------------|-----------------------------------|------------------------------------|---|
| NED<br>NW Dredging    | CW1_BR-Redfish_700                | 53.9                               | -   |
|                       | BE1_028+605_530                   | 11                                 | -   |
|                       | CW2_BSC_455                       | 3.9                                | -   |
|                       | BE2_BSCFlare                      | 10.6                               | -   |
|                       | CW3_BCC_455 & BETB3_BCCFlare_1800 | 3.0                                | -   |
| LPP<br>NW Dredging    | CW1_Redfish-BSC_700               | 184.5                              | -   |
|                       | CW1_BSC-BCC_700                   | 128.2                              | -   |
| Potential<br>New PA's | Mid Bay Expansion North           | 5.7                                | 127.5   |
|                       | Mid Bay Expansion South           | 32.1                               | 127.5   |
|                       | Upland Concept 1                  | 0.3                                | 151.9   |

## 7.4 Wetlands

Potential wetland areas totaling less than 6 acres are located in areas where sediment normally accumulates along the channel near the confluence of Sims Bayou and the HSC, just upstream and downstream of the BW-8 Bridge, adjacent to the Lynchburg ferry landing, southwest section of Alexander Island PA, and adjacent to the Fred Hartman Bridge. More detail on these areas are provided in Appendix P of the FSEIS. The RP channel improvements would not be expected to have adverse indirect effects to wetlands by inducing landside population growth or changes in land use. The RP would also not be expected to indirectly change the surface hydrology or reduce tidal inundation of wetlands. Another mitigation cost accounted for is for impacts to forest and herbaceous shrub at the BW-8 (30.0 acres) and E2C (6.3 acres) tracts. This mitigation is to be paid into an FCU mitigation bank as described in Appendix P of the FSEIS.

## 7.5 Hazardous and Toxic Materials

To complete a feasibility level hazardous, toxic, and radioactive waste (HTRW) evaluation for the HSC ECIP, following the rules and guidance of ER 1165-2-132, *HTRW Guidance for Civil Works Projects* (USACE, 1992), and ASTM E1527-13 *Standard Practice for Environmental Site Assessment: Phase I Environmental Site Assessment Process* (ASTM International, 2013) was conducted and is provided in Appendix G. The proposed project occurs entirely in-water, so per civil works guidance, no HTRW sites are found within the project footprint. However, several HTRW sites can be found in near proximity to the proposed project footprint. These sites are listed below, along with the action recommendation.

Table 7-2: HTRW Sites Near Project Vicinity

| Site                     | Location   | REC   | Action Recommendation   |
|--------------------------|--|---|---|
| Patrick Bayou            | 1.8 mi E of BW-8 bridge, Harris County                       | NPL site, sediment contaminated with PAHs, metals, and PCBs   | Avoidance of widening measures in this area to the HSC  |
| San Jacinto Waste Pits   | Immediately N of I10 bridge @ San Jacinto River, Channelview | NPL site, sediment contaminated with dioxin   | Chemical sediment quality sampling within HSC portion of AOC, in accordance with 2009 EPA public notice |
| Pasadena Refining System | 0.25 mi E of Washburn Tunnel, Pasadena                       | Past RCRA investigations and corrective actions, TSDF, active institutional controls                              | Avoidance of widening measures in this area to the HSC  |
| South Coast Terminals    | 0.1 mi E of I-610 bridge, Houston                            | Past state enforcement orders, active VCP remediation ongoing, soil and GW contaminated with VOCs, BTEX, and PAHs | Avoidance of widening measures in this area of HSC  |
| Lone Star Industries     | 0.1 mi E of Brady Island, Houston                            | Active VCP investigation ongoing, soil and GW contaminated with VOCs, SVOCs, metals, and TPH                      | Avoidance of widening measures in this area of HSC  |
| Pasadena Terminal        | 0.4 mi S of Hunting Bayou, Pasadena                          | Past state enforcement orders, active institutional controls  | Avoidance of widening measures in this area to the HSC  |
| Oxid, LP                 | 0.1 mi E of I-610 bridge, Houston                            | Active VCP remediation ongoing, soil and GW contaminated with solvents and metals                                 | Avoidance of widening measures in this area of HSC  |

An HTRW evaluation was also conducted for the proposed new upland PAs, E2 Clinton, Rosa Allen Extension, and Beltway 8. Neither E2 Clinton nor Rosa Allen Extension had any HTRW concerns. The Beltway 8 property has an HTRW history, but discussion with the TCEQ indicated the site was safe for proposed use as an upland PA. Refer to Section 1.3.7.1 of Appendix G for further discussion of Beltway 8.

## **7.6 Salinity Modeling with AdH**

This is abstracted from an ERDC Technical Report “Houston Ship Channel 45-Foot Expansion Channel Improvement Project (ECIP) Numerical Modeling Report” by Jennifer McAlpin, Cassandra Ross, and Jared McKnight, ERDC.

Hydrodynamic and salinity modeling of present conditions is complete. Initial runs were provided to SWG, feedback was returned, and models were rerun. Problems with matching model results and measurements of salinity in Trinity Bay were resolved on later runs by (a) adjusting diffusion and bed roughness that were unmeasured within the acceptable range and (b) rainfall and evaporation were added.

SWG provided a project alternative that includes channel widening, deepening, and bend easing. The model is run for “present” year zero (2029) and “future” year 50 (2079) with and without project.

The model shows that the salinity does not vary greatly when the project is in place. Changes to salinity are 2 ppt or less. The tidal prism increases by less than 2% when the project is included and the tidal amplitudes increase by no more than 0.01 m. The residual velocity vectors do vary in and around areas where project modifications are made – along the HSC, BSC, and BCC.

### **7.6.1 Model Results**

SWG provided a project alternative that includes channel widening, deepening, and bend easing. The model is run for “present” year zero (2029) and “future” year 50 (2079) with and without project.

The model shows that the salinity does not vary greatly when the project is in place. Changes to salinity are 2 ppt or less. The tidal prism increases by less than 2% when the project is included and the tidal amplitudes increase by no more than 0.01 m. The residual velocity vectors do vary in and around areas where project modifications are made – along the HSC, BSC, and BCC.

The variation in salinity between present and future conditions is significant as expected. The rise in water surface elevation due to sea level changes as well as a reduction in freshwater inflow for future conditions generates very different salinity magnitudes throughout the analysis year. In most locations the mean salinity is larger for the future conditions. However, the variation in salinity between with and without project alternatives is quite small for most locations – generally

less than 2 ppt. The largest variation in salinity between with and without project results is in the upstream locations of the HSC. The salinities are almost identical near the entrance but begin to diverge further into the system at Mid Bay Marsh, Morgan’s Point, and locations further up the HSC. However, the change in the mean salinity between with and without project remains within 2 ppt. This behavior is visible in the point analysis as well as in the cross sectional analysis to be discussed in the next section. The time history of salinity includes dotted lines for 10 ppt and 15 ppt thresholds. The with project conditions generally maintains the pattern of the salinity over time but does increase above these thresholds for short periods of time at some locations.

### 7.6.2 Salinity Slice Analysis

A slice along the center of the HSC from the Gulf of Mexico to the HSC Turning Basin allows for the comparison of the salinity wedge migration along the ship channel. These results are for mean salinity over the year-long analysis period. Figure 7-2 shows the location of key features along the HSC for reference.

Figure 7-3 shows the mean salinity along the HSC for all four alternatives. Again, when viewing these results, focus on changes between the present with and without project separately from the future with and without project in order to isolate impacts due to the project.

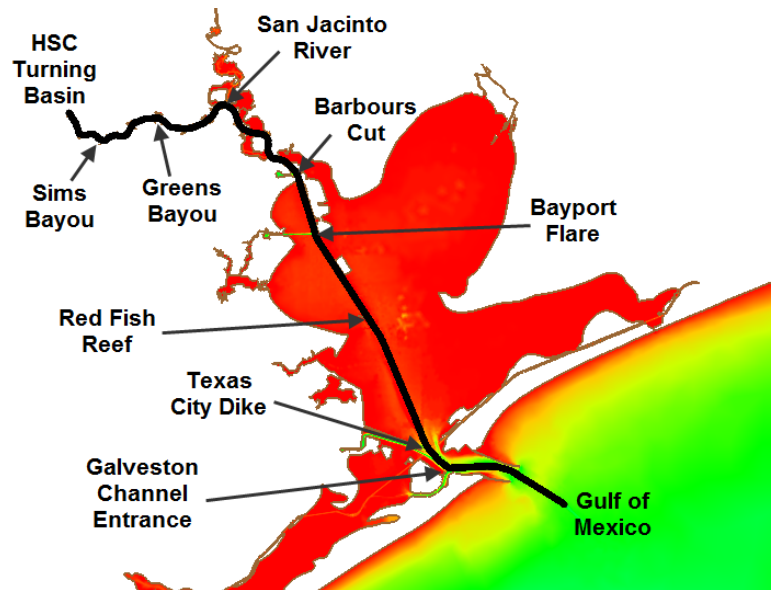

Figure 7-2: HSC key feature reference map

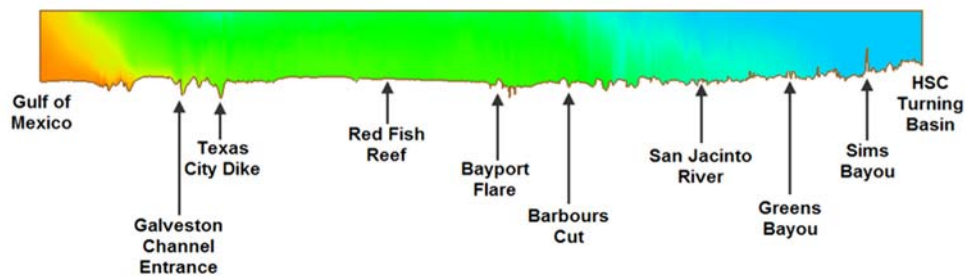

Figure 7-3: HSC slice analysis reference map



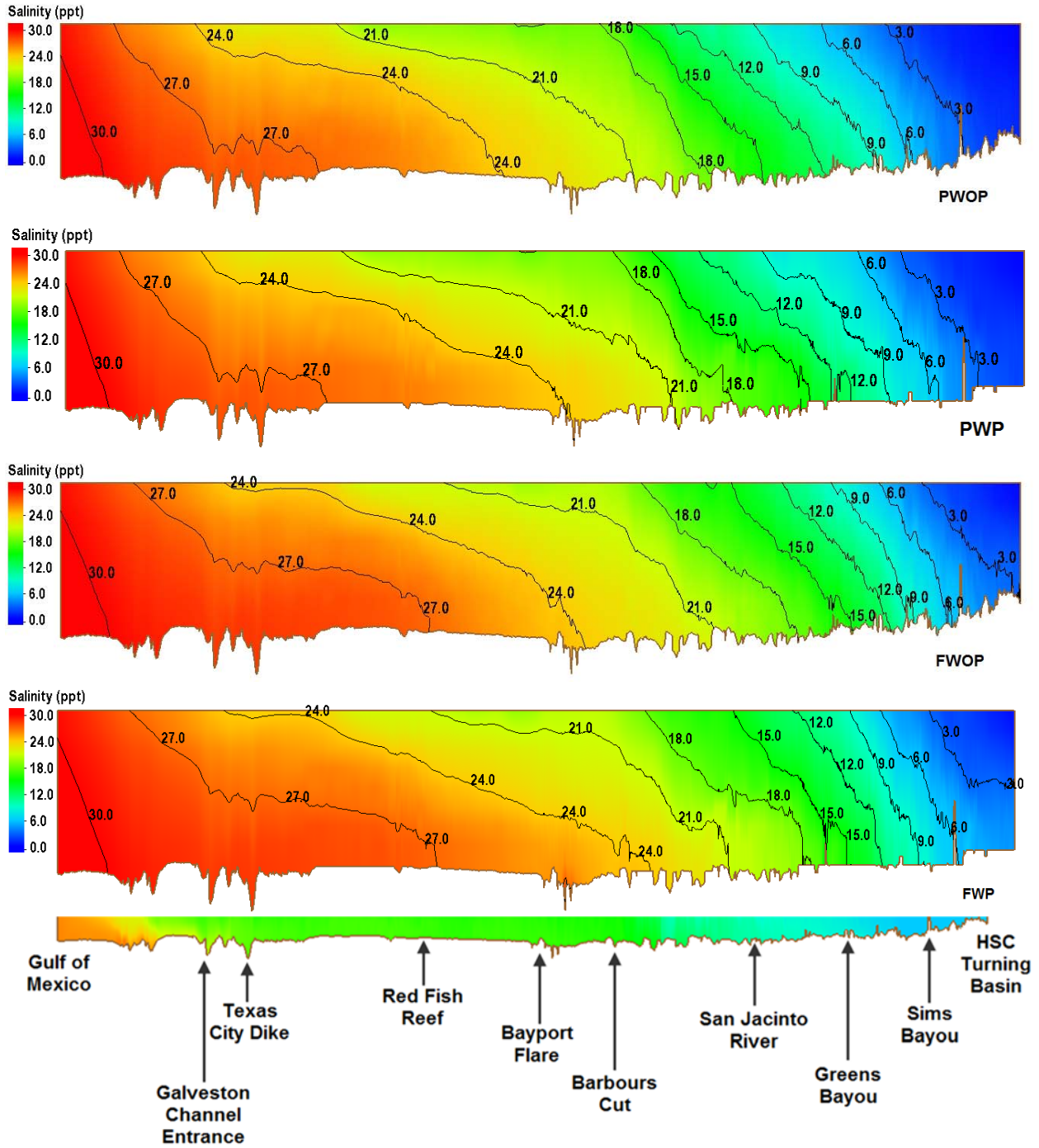

Figure 7-4: HSC average salinity slice results

## 7.7 Dissolved Oxygen

Analysis of dissolved oxygen (DO) of the GBANC is discussed in detail in Appendix G.

## 8 REAL ESTATE

---

### 8.1 Real Estate Considerations

The NFS is responsible for acquiring and furnishing all lands, easements, rights-of-way, relocations (i.e., P.L. 91-646 relocations and utility/facility relocations), borrow material, and dredged or excavated material disposal areas (LERRD) for the project, if required. The real estate requirements for the Project must support construction as well as the continued operation and maintenance of the Project.

#### 8.1.1 Lands, Easements, and Rights-of-Way

This channel improvement project will overlap the existing HSC project as discussed in the “Purpose” section of the Real Estate Plan (REP). The alignment of the NED Plan and LPP is located mostly on open waters of Galveston Bay and HSC. Portions of the additional submerged lands required over Galveston Bay are owned by TxGLO and would be utilized under navigational servitude. A total of 50 TxGLO submerged tracts were identified as being utilized under navigational servitude. These tracts are located from Bolivar Roads to Barbers Cut. A table of these tracts is shown in the REP, Exhibit D. A total of 45 Tracts were identified as NFS owned land via patent by the State of Texas. The PHA currently has a development easement extending approximately 230 feet from the improved channel toe along the north side of the BSC for future development. A table of these tracts is shown in the REP, Exhibit E. These submerged lands are located at the BSC and BCC through the upper bayou of this project.

Segment 6 will include turning basin improvements at Brady Island, which will require the land shaving of 0.096 acres requiring land acquisition in fee. As additional requirement for this feature is a one-acre staging/temporary work area easement on Brady Island situated adjacent to the Brady Island land shaving feature for the term of one year. Access to the staging area will utilize public roads leading into Brady Island.



## 9 UTILITIES AND FACILITIES

---

As the underlying property owner of most submerged lands in Harris County, the NFS licenses the use of these lands to third parties, such as pipeline owners. The NSF currently tracks over 1,000 pipeline licenses and easements across its properties. As such, the NFS conducted an analysis of pipelines crossing the channel where proposed improvements to the channel were stated at the TSP level. The data was derived from PHA license data, permit documents, as-built documents, and state and Federal databases. For the pipelines within Chambers and Galveston Counties, the NFS contacted the pipeline companies disclosed in State databases such as the Texas Railroad Commission and Texas General Land Office. PHA has assessed all available data for pipelines crossing the HSC and this report focuses efforts on the pipelines with potential impact. PAs, BU areas, and mitigation sites were located in such way to not impact pipelines or assumed to allow for a symbiotic coexistence.

Approximate locations of pipelines shown on Engineering Plates were downloaded from the Texas Railroad Commission. Pipeline locations are only as accurate as the data sources and must be verified by the construction designer Engineer-of-Record and the construction contractor prior to construction.

During TSP, 103 potential conflicts were evaluated. In post ADM analysis, this number was reduced to 58 potential pipeline conflicts. Of these 58 identified pipelines, 14 pipelines will require additional evaluation during PED, but have been slated for removal and relocation in this documentation for budgeting purposes. One pipeline in Segment 1 has been identified to have less than optimal cover after project completion and would require more detailed analysis during PED. The remaining 13 pipelines all are located in Segment 4. Nine pipelines have been targeted to having less than ten feet cover along parts of the pipeline after the channel has been deepened or widened with significant overdepth provided. Although presented within this documentation to be relocated, four of these pipelines are candidates to remain in place with additional anchoring to ensure no further future movement. The remaining five pipelines (two corridors) are expected to be relocated as the expected remaining cover along the edges are within construction instrumentation tolerance and risk of damage would be almost certain without relocation.

A few pipelines, usually abandoned in place, may predate documentation of such and present a risk of being discovered during construction. The full list of pipelines evaluated, and corresponding costs are located in Attachment 2 of this Appendix. Pipeline specific information is available upon request.

*(This page left blank intentionally.)*

# 10 COSTS

---

## 10.1 Introduction

### 10.1.1 General

The following section identifies the measures evaluated and assumptions used in development of the cost estimates for the HSC-ECIP. The cost components are broken out into categories that include dredging, earthwork, and ancillary. Costs have been developed for both the initial construction (1<sup>st</sup> costs) and for 50 years of operation and maintenance (O&M). Where practical, cost development was held consistent between various options in order to rapidly evaluate numerous scenarios; where distances, quantities, and materials are the changing variables affecting costs. For new work dredging, the costs only include the pay quantity costs of the required material to be removed. Non-pay over-dredging by the contractor was not considered in total prices, but rather incidental to the new work dredging. For O&M, the quantities used were those as described in Table 5-10, and include non-pay quantities.

### 10.1.2 Equipment & Labor

This report identifies the measures evaluated and assumptions used in development of the cost estimates for the HSC-ECIP. The cost components are broken out into categories that include dredging, earthwork, and ancillary. Costs have been developed for both the initial construction (1<sup>st</sup> costs) and for 50 years of operation and maintenance (O&M). Where practical, cost development was held consistent between various options in order to rapidly evaluate numerous scenarios; where distances, quantities, and materials are the changing variables affecting costs.

## 10.2 Project First Costs

### 10.2.1 General

The project measures include various options for improvements to the HSC, as well as the connected channels BSC and BCC. These measures require the dredging of new work (NW) materials. The study locations are broken up by segments. Segment 1 consists of three HSC reaches, Bolivar Roads to Redfish, Redfish to BSC, and BSC to BCC. Segment 2 is the BSC and Segment 3 is BCC. Segment 4 includes the HSC reaches of Boggy Bayou to Greens Bayou and Greens Bayou to Sims Bayou. Segment 5 is Sims Bayou to the I-610 Bridge and Segment 6 is between the I-610 Bridge through the Main Turning Basin. Dredging cost estimates are a function of the material to be dredged and where/how the material is to be placed. Additional criteria are derived therefrom and include the selected plant, shoreside costs, and costs of ancillary tasks.

The locations of dredging construction included in the study are provided below for both NED and LPP versions:

Table 10-1: HSC-ECIP Study Channel Measures

| PLAN                           | SEG.           | MEASURE                  | STATION(S)                         | DESCRIPTION   |
|--------------------------------|----------------|--------------------------|------------------------------------|---|
| NED                            | 1              | CW1_BR-Redfish_700       | 138+369 – 078+844                  | Widen HSC between Bolivar to Redfish to 700-foot width. Includes bend easings.  |
|                                |                |                          | 078+844 – 073+934                  | Bottleneck transition back to existing 530-foot channel.                        |
|                                |                | BE1_028+605_530          | 031+171 – 028+605                  | Bend easing within Redfish to BSC reach.  |
|                                |                |                          | 028+605 – 026+028                  | Bend easing within BSC to BCC reach.  |
|                                | 2              | CW2_BSC_455              | 025+58 – 222+76                    | Widen BSC on north side to 455-foot width.                                      |
|                                |                | BE2_BSCFlare             | 203+66 – 239+78                    | Widen BSC south side flare radius to 5,375 feet.                                |
|                                | 3              | CW3_BCC_455              | 24+69 – 67+11                      | Widen BCC on north side to 455-foot width.                                      |
|                                |                | BETB3_BCCFlare_1800      | 08+78 – 30+84                      | Widen BCC flare on north and south to create 1,800-foot diameter turning basin. |
|                                | 4              | CW4_BB-GB_530            | 684+03 – 833+05                    | Widen HSC between Boggy Bayou to Greens Bayou to 530-foot width.                |
|                                |                | CD4_Whole <sup>(1)</sup> | 684+03 – 974+08                    | Deepen HSC between Boggy Bayou to Hunting Turning Basin                         |
|                                | 5              | CD5_Whole                | 1110+78 – 1160+62                  | Deepen HSC between Sims Bayou to I-610 Bridge.                                  |
|                                | 6              | CD6_Whole                | 1266+49=00+00 – 30+95              | Deepen HSC between I-610 Bridge and Main Turning Basin.                         |
|                                |                | TB6_Brady_900            | 1189+15.688 – 1203+14.265          | 900-foot Turning Basin at Brady Island  |
|                                | LPP Add'l Work | 1                        | CW1_Redfish-BSC_700 <sup>(2)</sup> | 073+934 – 028+605   |
| CW1_BSC-BCC_700 <sup>(2)</sup> |                |                          | 028+605 – (-)3.94                  | Widen HSC between BSC to BCC to 700-foot width. Includes bend easings.          |

Notes:

1. For dredging/cost purposes these measures were separated as *Boggy to Greens* and *Greens to Sims*, where *Boggy to Greens* includes both the widening (where applicable) and deepening, and *Greens to Sims* includes only deepening (to Washburn Tunnel).
2. If full bay widening extended, eliminates need for BE2\_BSCFlare

### 10.2.2 NW Materials to be Dredged

As detailed in Section 6.3, historical boring logs were reviewed to determine the material types for the proposed channel measures. This analysis found that parts of Bolivar to Redfish and Redfish to BSC have a higher than desired percentage of very soft to soft silts and clays. These materials are difficult, if not impossible, to build new sites with via hydraulic pumping as they generally do not fall out at the end of the dredge pipe, but rather run out with little to no retainage. Therefore, the alternative to using for construction would be to mechanically dredge the sections of predominantly softer material, and only use the sections with generally suitable material for new site construction projects. These reaches are re-presented broken out accordingly below.

Table 10-2: Segment 1 – Bolivar to Redfish Materials (Reach Separation by Quality)

| Material Type:            | Station 138+369 to 100+000 |            | Station 100+000 to 78+844 |            |
|---------------------------|----------------------------|------------|---------------------------|------------|
|                           | Quantity (CY)              | % of Total | Quantity (CY)             | % of Total |
| Very Soft Silts & Clays   | 91,530                     | 4.59%      | 1,545,850                 | 80.15%     |
| Soft Silts & Clays        | 79,101                     | 3.97%      | 336,392                   | 17.44%     |
| Medium Clays              | 80,030                     | 4.01%      | 10                        | 0.00%      |
| Stiff Clays               | 631,836                    | 31.69%     | 111                       | 0.01%      |
| Very Stiff Clays          | 661,553                    | 33.19%     | 32                        | 0.00%      |
| Hard Clays                | 94,050                     | 4.72%      | 11                        | 0.00%      |
| Loose Sands               | 105,819                    | 5.31%      | 42,999                    | 2.23%      |
| Medium Dense Sands        | 154,116                    | 7.73%      | 3,176                     | 0.16%      |
| Dense to Very Dense Sands | 404                        | 0.02%      | 10                        | 0.00%      |
| Medium to Dense Silts     | 95,091                     | 4.77%      | 10                        | 0.00%      |
| Total NW                  | 1,993,531                  | 100%       | 1,928,600                 | 100%       |

Table 10-3: Segment 1 – Redfish to BSC Materials (Reach Separation by Quality)

| Material Type:            | Station 78+844 to 57+000 |            | Station 57+000 to 28+604 |            |
|---------------------------|--------------------------|------------|--------------------------|------------|
|                           | Quantity (CY)            | % of Total | Quantity (CY)            | % of Total |
| Very Soft Silts & Clays   | 2,370,358                | 66.16%     | 891,335                  | 17.10%     |
| Soft Silts & Clays        | 1,048,646                | 29.27%     | 1,664,219                | 31.94%     |
| Medium Clays              | 128,755                  | 3.59%      | 37,229                   | 0.71%      |
| Stiff Clays               | 498                      | 0.01%      | 338,781                  | 6.50%      |
| Very Stiff Clays          | 487                      | 0.01%      | 463,396                  | 8.89%      |
| Hard Clays                | 0                        | 0.00%      | 0                        | 0.00%      |
| Loose Sands               | 14,350                   | 0.40%      | 179,344                  | 3.44%      |
| Medium Dense Sands        | 338                      | 0.01%      | 749,573                  | 14.38%     |
| Dense to Very Dense Sands | 18,988                   | 0.53%      | 570,662                  | 10.95%     |
| Medium to Dense Silts     | 338                      | 0.01%      | 316,607                  | 6.08%      |
| Total NW                  | 3,582,727                | 100%       | 5,211,146                | 100%       |

In general, the south side of Bolivar to Redfish has materials in line with those typically used for new site construction. There is a large area within the north side of Bolivar to Redfish and the south side of Redfish to BSC (Stations 57+000 to 100+000) with a high concentration of soft and very soft silts and clays. The material gets again more suitable in the north side of Redfish to BSC and significantly better throughout BSC to BCC.

### 10.2.3 NW Placement Options

Potential options were developed to use the new work dredge materials from the proposed measures to determine options to develop the least cost plan. Not all of these options are constructed. Options include new marshes and UCPAs for O&M capacity; and UCPAs for new work site fill only (bird islands, instant marshes, etc.) Each option includes its own assumptions applicable for dredging. Each channel segment and/or reach establishes discrete alternatives that utilize all the new work and maintenance for that segment and/or reach. Options may be constructed from multiple reaches as developed in options. I.e., options falling in vicinity of Redfish to BSC reach may ultimately be constructed from new work materials from BSC or BSC to BCC reach, etc. All options below and including BCC assume the use of a 30-inch hydraulic

dredge. Options above BCC assume use of a 24-inch dredge. The potential options are provided below.

Table 10-4: NW Placement Options

| Placement Option        | Description   | NW Qty. Req. (CY) |
|-------------------------|---|-------------------|
| 8-acre Bird Island      | New approx. 8-acre emergent bird island habitat <ul style="list-style-type: none"> <li>Assumes use of 30-inch hydraulic dredge</li> <li>2,227 feet of armored shoreline requiring 16,385 tons of armor stone</li> <li>No new O&amp;M capacity created</li> </ul>  | 911,000           |
| Long Bird Island        | New approx. 6-acre emergent bird island habitat with adjacent oyster reef/wave trip <ul style="list-style-type: none"> <li>Assumes use of 30-inch hydraulic dredge</li> <li>2,237 feet of armored shoreline requiring 13,528 tons of armor stone</li> <li>100-foot in width by 1,748 feet long oyster reef wave trip requiring 21,236 tons of cultch material</li> <li>No new O&amp;M capacity created</li> <li>Creates approx. 4-acre oyster mitigation credit</li> </ul>                      | 1,172,000         |
| Bolivar New Marsh       | New approx. 37-acre marsh constructed to marsh grade (+1.3' MLLW +/-) <ul style="list-style-type: none"> <li>Assumes use of 30-inch hydraulic dredge</li> <li>3,803 feet of armored shoreline requiring 24,290 tons of armor stone</li> <li>Requires increased level of construction effort from shaping both constructed dike and interior fill elevations/channelization/etc.</li> <li>No new O&amp;M capacity created</li> <li>Eliminated in screening</li> </ul>                            | 1,994,000         |
| Mid Bay Expansion North | New 293-acre UCPA expansion on north side of existing Mid Bay DMPA <ul style="list-style-type: none"> <li>Assumes use of 30-inch hydraulic dredge</li> <li>10,297 feet of armored shoreline requiring 72,732 tons of armor stone</li> <li>Requires relocation of Boaters Cut channel</li> <li>Est. 32,300,000 CY O&amp;M capacity created</li> <li>Creates 5.7 acres of increased oyster impact</li> <li>Creates 128 acres of bay bottom impact</li> <li>Eliminated in screening</li> </ul>     | 2,800,000         |
| Mid Bay Expansion South | New 293-acre UCPA expansion on south side of existing Mid Bay DMPA <ul style="list-style-type: none"> <li>Assumes use of 30-inch hydraulic dredge</li> <li>10,297 feet of armored shoreline requiring 72,732 tons of armor stone</li> <li>No required relocation of Boaters Cut channel</li> <li>Est. 32,300,000 CY O&amp;M capacity created</li> <li>Creates 32.1 acres of increased oyster impact</li> <li>Creates 128 acres of bay bottom impact</li> <li>Eliminated in screening</li> </ul> | 2,800,000         |
| Upland Concept 1        | New 340-acre UCPA north east of existing Mid Bay DMPA <ul style="list-style-type: none"> <li>Assumes use of 30-inch hydraulic dredge</li> <li>16,824 feet of armored shoreline requiring 118,109 tons of armor stone</li> <li>No required relocation of Boaters Cut channel</li> <li>Est. 37,552,000 CY O&amp;M capacity created</li> <li>Creates 0.3 acres of increased oyster impact</li> <li>Creates 152 acres of bay bottom impact</li> <li>Eliminated in screening</li> </ul>              | 4,500,000         |



|                                       |   |           |
|---------------------------------------|---|-----------|
| Bird Island Marsh                     | <p>New 402-acre marsh placement area with three attached bird islands, east of existing Mid Bay DMPA</p> <ul style="list-style-type: none"> <li>Assumes use of 30-inch hydraulic dredge</li> <li>15,672 feet of armored shoreline requiring 94,774 tons of armor stone</li> <li>100-feet in width by 6,375 feet long oyster reef wave trip requiring 74,855 tons of cultch material</li> <li>Est. 6,300,000 CY O&amp;M capacity created</li> <li>Creates apprx. 11.1-acre oyster mitigation credit</li> </ul> | 4,270,000 |
| Atkinson Marsh Cell M11               | <p>New 445-acre marsh cell at Atkinson Island</p> <ul style="list-style-type: none"> <li>Assumes use of 30-inch hydraulic dredge</li> <li>9,455 feet of wide unarmored dike with flat slope</li> <li>Est. 9,500,000 CY O&amp;M capacity created</li> </ul>  | 2,800,000 |
| Atkinson Marsh Cell M7/8/9            | <p>Repair/complete existing marsh cell at Atkinson Island</p> <ul style="list-style-type: none"> <li>Assumes use of 30-inch hydraulic dredge</li> <li>Completion of wide unarmored dike with flat slope</li> <li>Est. 1,735,000 CY O&amp;M capacity created</li> </ul>  | 600,000   |
| Atkinson Marsh Cell M12               | <p>New 273-acre marsh cell at Atkinson Island</p> <ul style="list-style-type: none"> <li>Assumes use of 30-inch hydraulic dredge</li> <li>7,785 feet of armored shoreline requiring 49,723 tons of armor stone</li> <li>Includes sweeping cedar bayou upon completion</li> <li>Est. 6,000,000 CY O&amp;M capacity created</li> </ul>  | 4,500,000 |
| BSC Sedimentation Attenuation Feature | <p>New emergent dike for sedimentation diversion to decrease shoaling at BSC Flare</p> <ul style="list-style-type: none"> <li>Assumes use of 30-inch hydraulic dredge</li> <li>9,400 feet of armored shoreline (all sides) requiring 318,773 tons of armor stone</li> <li>No new O&amp;M capacity created</li> </ul>  | 800,000   |
| Spilman Island NW Berm                | <p>New work placed into a berm along the interior side of existing dike to stockpile for future dike raise</p> <ul style="list-style-type: none"> <li>Assumes use of 30-inch hydraulic dredge</li> <li>No new O&amp;M capacity created</li> <li>Eliminated in screening</li> </ul>  | 2,825,000 |
| Alexander Island New Marsh            | <p>New apprx. 57-acre marsh constructed to marsh grade (+1.3' MLLW +/-)</p> <ul style="list-style-type: none"> <li>Assumes use of 30-inch hydraulic dredge</li> <li>3,854 feet of armored shoreline requiring 24,616 tons of armor stone</li> <li>Requires increased level of construction effort from shaping both constructed dike and interior fill elevations/channelization/etc.</li> <li>No new O&amp;M capacity created</li> <li>Eliminated in screening</li> </ul>                                    | 2,825,000 |
| Beltway 8 Tract                       | <p>New work placed into even lifts onto PHA BW-8 Tract</p> <ul style="list-style-type: none"> <li>Assumes use of 24-inch hydraulic dredge</li> <li>Apprx. 5-foot of fill on property</li> <li>Initial apprx. 9-foot dike creation to contain fill</li> <li>Installation of one spillbox</li> <li>No new O&amp;M capacity created</li> </ul>   | 2,920,000 |
| E2 Clinton                            | <p>New work placed into even lifts onto PHA E2Cn Tract</p> <ul style="list-style-type: none"> <li>Assumes use of 24-inch hydraulic dredge</li> <li>Apprx. 5-foot of fill on property</li> <li>Initial apprx. 9-foot dike creation to contain fill</li> <li>Installation of one spillbox</li> <li>Includes real estate costs</li> <li>No new O&amp;M capacity created</li> </ul>   | 562,000   |

|                      |   |           |
|----------------------|---|-----------|
| Glendale             | New work placed into even lifts onto existing Glendale PA <ul style="list-style-type: none"> <li>Assumes use of 24-inch hydraulic dredge</li> <li>Apprx. 3-foot of fill on property</li> <li>Initial apprx. 7-foot dike raise to contain fill</li> <li>Assumes use of existing spillboxes</li> <li>No new O&amp;M capacity created</li> </ul>   | 910,000   |
| Filter Bed           | New work placed into even lifts onto existing Glendale PA <ul style="list-style-type: none"> <li>Assumes use of 24-inch hydraulic dredge</li> <li>Apprx. 2-foot of fill on property</li> <li>Initial apprx. 6-foot dike raise to contain fill</li> <li>Assumes use of existing spillboxes</li> <li>No new O&amp;M capacity created</li> </ul>   | 267,000   |
| Rosa Allen Expansion | New work placed into even lifts onto PHA Rosa Allen Expansion Tract <ul style="list-style-type: none"> <li>Assumes use of 24-inch hydraulic dredge</li> <li>Apprx. 5-foot of fill on property</li> <li>Initial apprx. 9-foot dike raise to contain fill</li> <li>Installation of one spillbox</li> <li>Includes real estate costs</li> <li>No new O&amp;M capacity created</li> <li>Assumes site not used for future O&amp;M</li> </ul> | 1,177,000 |

## 10.2.4 NW Production Variables

### 10.2.4.1 Pipeline Lengths

Production rates were developed for all dredging scenarios. For the NW dredging, the materials derived from the boring logs were used for each reach. The various proposed new sites for construction were used for development of lines and lengths. NW dredging by hydraulic methods was assumed pump limited. Clamshell dredging production rates were determined based predominantly on sail distances as well as equipment operating capacities.

Table 10-5: New Work Dredging Pipeline Lengths

| Reach                                     | Placement Location    | PL Min. (FT) | PL Max. (FT) | PL Avg. (FT) |
|---|-----------------------|--------------|--------------|--------------|
| Bolivar - Redfish<br>(100+000 to 138+369) | 8-AC Bird Island      | 10,500       | 32,500       | 23,000       |
|   | Long Bird Island      | 10,500       | 42,000       | 23,000       |
|   | Bolivar Instant Marsh | 13,000       | 37,000       | 26,000       |
| Redfish - BSC<br>(028+604 to 057+000)     | Bird Island Marsh     | 20,500       | 45,000       | 30,000       |
|   | Mid Bay Exp. S        | 10,500       | 31,500       | 18,500       |
|   | Mid Bay Exp. N        | 10,500       | 29,000       | 20,000       |
|   | Upland Concept 1      | 23,500       | 42,000       | 33,000       |
|   | M11                   | 17,500       | 46,000       | 31,500       |
| BSC - BCC<br>(-3.94 to 028+604)           | Upland Concept 1      | 26,000       | 55,000       | 40,500       |
|   | Mid Bay Exp. N        | 17,000       | 46,000       | 31,500       |
|   | Mid Bay Exp. S        | 26,500       | 55,000       | 41,000       |
|   | M11                   | 10,500       | 32,000       | 20,000       |
|   | M12                   | 9,500        | 38,500       | 24,000       |
|   | Bird Island Marsh     | 33,000       | 61,500       | 47,000       |

|  |                           |        |        |        |
|--|---------------------------|--------|--------|--------|
| BSC/BSC Flare<br>(25+58 to 239+00)         | Sedimentation Attenuation | 1,500  | 26,000 | 11,500 |
|  | Upland Concept 1          | 21,000 | 43,000 | 32,000 |
|  | Mid Bay Exp. N            | 22,000 | 44,000 | 33,000 |
|  | Mid Bay Exp. S            | 36,000 | 58,000 | 47,000 |
|  | Bird Island Marsh         | 37,500 | 59,000 | 48,500 |
|  | M11                       | 20,000 | 41,500 | 31,000 |
| BCC/BCC Flare<br>(8+78 to 67+11)           | M12                       | 12,000 | 18,000 | 15,000 |
|  | Spilman Island            | 1,000  | 12,500 | 10,000 |
|  | Alexander Marsh           | 26,000 | 30,000 | 28,000 |
| Boggy - Greens<br>(676+54 to 850+00)       | BW-8 Tract                | 5,500  | 18,500 | 11,000 |
| Greens – Sims<br>(850+00 to 974+08)        | E2C                       | 13,500 | 21,500 | 18,000 |
| Sims – 610<br>(1110+78 to 1160+62)         | Glendale                  | 7,000  | 21,000 | 12,000 |
| 610 – Turning Basin<br>(1160+62 – 1266+48) | Glendale                  | 5,000  | 8,000  | 6,000  |
| Upper Bayou<br>(00+00 – 30+95)             | Filterbed                 | 25,000 | 44,000 | 34,500 |

#### 10.2.4.2 Haul Distances

As discussed previously, a portion of the new work materials that lie between Bolivar to Redfish and Redfish to BSC, between approximate Station 57+000 to 100+000, are considered unsuitable for new construction as per the available geotechnical data. This material will then be mechanically dredged and hauled offshore to ODMDS. Average production rates were developed for bucket dredging assuming a range of bucket sizes from 24 to 30 CY bucket sizes based on the materials, depths, haul distances, and standard equipment operating capabilities. For the reach, haul distances were determined as 18.1 nautical miles (nm) minimum, 25.1 nm maximum, and 21.6 nm average.

#### 10.2.5 NW Cost Considerations

Costs were estimated at 2018 price levels and assume standard construction practices. Equipment rates were derived from dredging experience, industry contractors, and several construction and equipment vendors. Labor rates were based on current industry typical standards.

##### 10.2.5.1 Mobilization

Mobilization and demobilization costs are difficult to estimate. This is in part due to industry growing more accustomed to rolling in additional profit and/or overhead costs and assumed risk into this line item. Additionally, it is impossible to determine the exact locations from where equipment will be mobilized. It is assumed that the necessary dredging plant to be mobilized is located within approximately 500 nautical miles of the project site. Mobilization costs vary due

to several factors including pipe required, equipment, personnel, and difficulty/type of work. I.e. mobilization for NW construction is generally much greater than that for O&M. Therefore, in order to develop estimated mobilization/demobilization costs for these estimates, historical pricing was analyzed for numerous past NW projects. The values were averaged and then inflated from the mid-point year to the study price year (2018).

Mobilizations for ancillary tasks were determined on case by case basis and assumed estimated actual equipment/labor costs required for transportation and setup of equipment. These options assumed approximately two weeks for mobilization.

#### **10.2.5.2 Dredging Prices**

Production analyses were run for each placement option based upon the material properties, pipeline and/or hauling distances, and equipment. These rates vary by location. Dredging unit costs were developed by estimating monthly operating and ownership costs of the dredges and attendant plant. The monthly operating costs were determined by calculating payroll costs, usage, repairs and maintenance, wear costs, marine insurance, fuel, operating supplies and consumables, and engineering and supervision for the operation of the various pieces of plant. Fuel cost used for all estimates was \$3.00/gallon. The operating costs for the various components vary in the dredge pipe requirements, energy costs, equipment, and personnel required for the work and to accommodate multiple placement sites and locations of work.

The operating costs are the costs of owning and maintaining the various pieces of dredging equipment and attendant plant. Estimated ownership costs provide for amortization (depreciation and interest on capital invested), periodic major repairs, the cost of an idle plant, the cost of yard facilities, and taxes and insurance. The operating and ownership costs are multiplied by the time required to perform the dredging based on the applied production rates and then summed. Additional cost percentages are added to this value to account for overhead, profit and bond. Finally, the cost of the work is divided by the dredge quantity to get a unit cost for the work.

#### **10.2.5.3 Hydraulic Fill Shaping**

This work item represents the landside work associated with new work dredging/new site construction. The operations are assumed to occur concurrently with the new work dredging, lasting for the duration of dredging, plus approximately 1 month for final shaping and grading. In the cases of new marsh construction (Bolivar New Marsh and Alexander New Marsh), where a marsh is to be constructed to grade, an additional month was added. This is to account for the 1 month required for final shaping and grading of the dikes, plus another month for shaping of the placed NW fill, circulation, channelization, etc.

---

#### **10.2.5.4 Shore Protection**

Typical sections were developed for the proposed dikes to be armored. These sections varied in dimensions. Total rock tonnages were calculated for each section for each placement area protected shoreline lengths assuming 165 PCF rock density with 38% voids. Based on a review of historical contract data, a rock price was developed and inflated to the study price year. The derived cost of \$96.70/ton was then multiplied by the tonnage required.

#### **10.2.5.5 Cultch Installation**

Two of the proposed new work construction options include areas of proposed oyster promoting wave trip features. These include the Long Bird Island and Bird Island Marsh. Cultch rock tonnages were applied over the sections and include an assumed 35% voids and a rock density of 150 PCF. Based on a review of historical contract data, a cultch rock price was developed and inflated to 2018 dollars. The derived cost of \$60/ton was then multiplied by the tonnage required.

#### **10.2.5.6 Initial Dike Raising**

This cost is applicable where new work materials are proposed to be placed onto upland tracts requiring an initial dike raise and includes the options at BW-8 Tract, E2C, RAE Tract, Filter Bed, and Glendale. For these considerations, an initial dike raise cost was developed for a raise height equal to the approximate fill height plus two feet of ponding and two feet of freeboard. The costs include initial dike raising heights of approximately 9-10 feet for BW-8, E2C, and RAE, 7 feet at Glendale, and 6 feet at Filter Bed. Quantities were developed assuming a 25-foot crown width, 3H:1V side slopes, and cut to fill loss percentage of 40% to account for losses and compaction. Additionally, included in dike raising are cost components for stripping, clearing, and grubbing prior to construction; as well as turfing post-construction.

#### **10.2.5.7 Real Estate**

Certain placement area options would contain associated real estate costs. These locations include the BW-8 Tract, E2C, and RAE. For estimating and screening purposes, real estate costs were retrieved from the Harris County Central Appraisal District (HCAD). USACE real estate costs are used in the final MCACES.

#### **10.2.5.8 Spillboxes**

New placement areas require installation of spillboxes. For these estimates, two new boxes were assumed for all newly constructed areas that would receive O&M material in the future. For BW-8 and E2C, as these areas are one time use sites for a single Federal dredging event of NW placement, only one spillbox was assumed. Historical prices were evaluated and averaged and

---

inflated to the study pricing year, which was approximately \$350,000/spill box. The spill box would be set in place and the dikes constructed around it. H-piles would not be necessary.

#### **10.2.5.9 Mitigation**

Due to environmental impacts resulting from the work, mitigation is required. There are two types of impacts considered in the Bay, oyster reef and bay bottom conversion. For impacted oyster reef, mitigation requirements are to construct new oyster reef in replacement. For bay bottom conversion where bay bottom is converted from underwater habitat to upland habitat (for example with new UCPA creation); mitigation can be a new environmentally beneficial feature, such as marsh creation.

For oyster mitigation, typical construction consists of cultch material placement. Pads are built of varying thickness (generally around 2.5 feet), with the constructed acreage being what meets the mitigation requirement. This is to be the case for mitigation required of the NED plan and would be constructed on a per contract/measure basis. For the LPP plan, a much larger mitigation acreage would be required. It was thus determined to perform all of its mitigation at one time, utilizing a portion of the new work materials to construct a base pad (at a dredging unit cost), thus requiring less rock to be placed to attain the necessary relief above the bay bottom. Depending on cultch thickness installed, oyster mitigation costs for the cultch vary from approximately \$67K to \$334K per acre. Depths surrounding the mitigation area are approximately -6 feet MLLW. Rock barges will be light loaded to reach the mitigation site.

For bay bottom conversion mitigation, historical pricing from a recent 288-acre marsh construction project was used to derive a cost per acre of marsh creation of about \$68K/acre as inflated to 2018 pricing. Mitigation requirements for each project component, and for each type, are provided in Table 7-1.

Another mitigation cost accounted for is that for impacts to forest and herbaceous shrub at the Beltway 8 (30.0 acres) and E2C (6.3 acres) tracts. This mitigation is to be paid into an FCU mitigation bank.

Additionally, there are two measures when considered that provide an offset to the required mitigation. These are Bird Island Marsh (11.1 acres) and Long Bird Island (4.0 acres). These sites share in common a component of cultch installation, that counts towards fulfilling the greater mitigation requirements.

#### **10.2.5.10 Boaters Cut Relocation**

Applicable to the proposed Mid Bay Expansion North option, this cost includes the costs associated with dredging a new boater's cut where the existing would be cut off by the proposed new placement area. This cost assumes the use of a 10-15 CY Clamshell dredge with material transport to ODMDS via dump scow.



### 10.2.5.11 Cedar Bayou Channel Sweeping

This cost component is included with construction new Atkinson Marsh Cell M12. As the site would be constructed adjacent to Cedar Bayou Navigation Channel, some infilling of the channel could occur from the dike filling operations. Therefore, the added task of sweeping the channel from its intersection with the HSC to the land cut has been added to the cost of construction of M12. This cost assumes the use of a 10-15 CY Clamshell dredge with material transport to ODMDS via dump scow.

### 10.2.6 Pipeline Relocations

Pipeline relocations and their costs were prepared by the PHA and provided in Attachment 2 of this Appendix. Pipeline specific information is available upon request.

### 10.2.7 Associated Costs

#### 10.2.7.1 LSF New Work Dredging

Limited data was available for estimating new work dredging costs associated with LSF. As such, the new work quantities estimated as shown in Table were used as separated by study segment. Only the groupings for Segment 4, as separated between Boggy to Greens and Greens to Sims, were evaluated. (The quantity derived for City Dock 16 in Segment 6 was too small to prepare a realistic independent estimate, and therefore was considered to be an incidental inclusion to channel dredging in the vicinity.) For the two parts of Segment 4, dredging cost estimates were developed for four known private placement areas: East Jones, West Jones, Deepwater, and Adloy. Estimates for all but Adloy were assumed to be done by hydraulic dredging methods. Due to the distance of Adloy from the dock locations, only mechanical dredging was assumed feasible. There is now way to know when the docks will be dredged in terms of facility owners working together to share mobilization costs, therefore it was assumed that all of the docks would be dredged under one mobilization. Separate events would increase the costs of dredging to all facility owners and should be considered by same in terms mobilization costs and placement area tipping fees. Table 10-6 below provides the evaluated dredging distances for each of the locations.

Table 10-6: LSF Dredging Distances

| Segment<br>4 Reach | East Jones   |              |              | West Jones   |              |              | Deepwater    |              |              | Adloy                |
|--------------------|--------------|--------------|--------------|--------------|--------------|--------------|--------------|--------------|--------------|----------------------|
|                    | Min.<br>(FT) | Max.<br>(FT) | Avg.<br>(FT) | Min.<br>(FT) | Max.<br>(FT) | Avg.<br>(FT) | Min.<br>(FT) | Max.<br>(FT) | Avg.<br>(FT) | Avg.<br>Haul<br>(NM) |
| BB-GB              | 9,500        | 22,500       | 13,500       | 11,000       | 24,000       | 15,500       | 10,000       | 22,500       | 18,500       | 14.9                 |
| GB-SB              | 6,000        | 9,000        | 8,000        | 5,500        | 8,500        | 6,500        | 28,000       | 35,500       | 33,000       | 17.1                 |

Materials were estimated to consist of the same types as those derived for their adjacent channel reaches. Similarly, the dredging spreads were also held consistent in terms of limiting the hydraulic methods to a 24-inch cutter suction dredge with attendant plant and required boosters. For the mechanical dredging work, a clamshell dredge with a heavy ten cubic yard bucket was assumed. Tipping fees (placement facility costs) were obtained for each placement area from the facility owner and/or manager. As of the dates of quotation, these were \$18/CY for East and West Jones, \$16/CY for Deepwater, and \$8/CY for Adloy. Total cost estimates for each of the segments are shown in Table 10-7.

Table 10-7: LSF Cost Estimates

| Segment 4 Reach | Docks   | NW Qty. (CY) | Dredging Cost |              |              |              |
|-----------------|---|--------------|---------------|--------------|--------------|--------------|
|                 |   |              | East Jones    | West Jones   | Deepwater    | Adloy        |
| BB-GB           | Enterprise, Kinder Morgan, P-L Jacintoport, Contanda, Magellan, ITC Pasadena, Bulk Plan, South Central Cement, Vulcan | 1,332,000    | \$44,600,000  | \$45,300,000 | \$43,500,000 | \$47,500,000 |
| GB-SB           | Greensport East/West, Magellan, Targa   | 439,000      | \$16,800,000  | \$16,800,000 | \$18,500,000 | \$16,600,000 |

### 10.2.7.2 ATONS

ATON costs were prepared by USCG Aids to Navigation office in Galveston, TX. This location is additionally the source of labor and equipment that would be performing the relocations. The following cost Table 10-8 were provided by USCG for each of the previously noted 86 ATONs requiring relocation.

Table 10-8: Cost for ATON Relocation

| LLNR  | NAME  | Cost         | LLNR  | NAME                          | Cost         |
|-------|---|--------------|-------|-------------------------------|--------------|
| 23900 | Houston Ship Channel Entrance Lighted Buoy 18   | \$ 14,772.00 | 24305 | Houston Ship Channel Light 65 | \$ 13,452.50 |
| 23955 | Houston Ship Channel Lighted Buoy 25            | \$ 14,772.00 | 24310 | Houston Ship Channel Light 66 | \$ 13,452.50 |
| 23960 | Houston Ship Channel Lighted Buoy 26            | \$ 14,772.00 | 24315 | Houston Ship Channel Light 67 | \$ 13,452.50 |
| 23965 | Houston Ship Channel Rock Pile Lighted Buoy 25A | \$ 14,772.00 | 24320 | Houston Ship Channel Light 68 | \$ 13,452.50 |
| 23985 | Houston Ship Channel Lighted Buoy 27            | \$ 14,772.00 | 24325 | Houston Ship Channel Light 69 | \$ 13,452.50 |
| 23990 | Houston Ship Channel Lighted Buoy 28            | \$ 14,772.00 | 24330 | Houston Ship Channel Light 70 | \$ 13,452.50 |
| 23995 | Houston Ship Channel Lighted Buoy 29            | \$ 14,772.00 | 24365 | Houston Ship Channel Light 71 | \$ 13,452.50 |
| 24000 | Houston Ship Channel Lighted Buoy 30            | \$ 14,772.00 | 24370 | Houston Ship Channel Light 72 | \$ 13,452.50 |
| 24005 | Houston Ship Channel Lighted Buoy 31            | \$ 14,772.00 | 24375 | Houston Ship Channel Light 73 | \$ 13,452.50 |

|       |                                      |              |       |  |               |
|-------|--------------------------------------|--------------|-------|--|---------------|
| 24010 | Houston Ship Channel Lighted Buoy 32 | \$ 14,772.00 | 24380 | Houston Ship Channel Light 74                | \$ 13,452.50  |
| 24015 | Houston Ship Channel Lighted Buoy 33 | \$ 14,772.00 | 24382 | HOUSTON SHIP CHANNEL LIGHT 74A               | \$ 13,452.50  |
| 24020 | Houston Ship Channel Lighted Buoy 34 | \$ 14,772.00 | 24385 | Houston Ship Channel Light 75                | \$ 13,452.50  |
| 24025 | Houston Ship Channel Light 35        | \$ 13,452.50 | 24390 | Houston Ship Channel Light 76                | \$ 13,452.50  |
| 24030 | Houston Ship Channel Light 35A       | \$ 13,452.50 | 24392 | HOUSTON SHIP CHANNEL LIGHT 76A               | \$ 13,452.50  |
| 24040 | Houston Ship Channel Light 36        | \$ 13,452.50 | 24430 | Bayport Ship Channel Outer Range Front Light | \$ 167,928.00 |
| 24045 | Houston Ship Channel Light 37        | \$ 13,452.50 | 24450 | Bayport Ship Channel Light 1                 | \$ 13,452.50  |
| 24050 | Houston Ship Channel Light 38        | \$ 13,452.50 | 24455 | Bayport Ship Channel Junction Light B        | \$ 13,452.50  |
| 24070 | Houston Ship Channel Light 39        | \$ 13,452.50 | 24460 | Bayport Ship Channel Light 2                 | \$ 13,452.50  |
| 24075 | Houston Ship Channel Light 40        | \$ 13,452.50 | 24475 | Bayport Ship Channel Light 3                 | \$ 13,452.50  |
| 24080 | Houston Ship Channel Light 41        | \$ 13,452.50 | 24480 | Bayport Ship Channel Light 4                 | \$ 13,452.50  |
| 24085 | Houston Ship Channel Light 42        | \$ 13,452.50 | 24485 | Bayport Ship Channel Light 5                 | \$ 13,452.50  |
| 24090 | Houston Ship Channel Light 43        | \$ 13,452.50 | 24490 | Bayport Ship Channel Light 6                 | \$ 13,452.50  |
| 24095 | Houston Ship Channel Light 44        | \$ 13,452.50 | 24500 | Bayport Ship Channel Light 8                 | \$ 13,452.50  |
| 24100 | Houston Ship Channel Light 45        | \$ 13,452.50 | 24520 | Houston Ship Channel Light 78                | \$ 13,452.50  |
| 24105 | Houston Ship Channel Light 46        | \$ 13,452.50 | 24525 | Houston Ship Channel Light 81                | \$ 13,452.50  |
| 24110 | Houston Ship Channel Light 47        | \$ 13,452.50 | 24530 | Houston Ship Channel Light 82                | \$ 13,452.50  |
| 24115 | Houston Ship Channel Light 48        | \$ 13,452.50 | 24535 | Houston Ship Channel Light 83                | \$ 13,452.50  |
| 24120 | Houston Ship Channel Light 49        | \$ 13,452.50 | 24540 | Houston Ship Channel Light 84                | \$ 13,452.50  |
| 24125 | Houston Ship Channel Light 50        | \$ 13,452.50 | 24545 | Houston Ship Channel Light 85                | \$ 13,452.50  |
| 24170 | Houston Ship Channel Light 51        | \$ 13,452.50 | 24550 | Houston Ship Channel Light 86                | \$ 13,452.50  |
| 24175 | Houston Ship Channel Light 52        | \$ 13,452.50 | 24555 | Houston Ship Channel Light 87                | \$ 13,452.50  |
| 24180 | Houston Ship Channel Light 53        | \$ 13,452.50 | 24560 | Houston Ship Channel Light 88                | \$ 13,452.50  |
| 24185 | Houston Ship Channel Light 54        | \$ 13,452.50 | 24565 | Houston Ship Channel Light 89                | \$ 13,452.50  |
| 24225 | Houston Ship Channel Light 55        | \$ 13,452.50 | 24570 | Houston Ship Channel Light 89A               | \$ 13,452.50  |

|            |                               |              |       |                                       |                |
|------------|-------------------------------|--------------|-------|---------------------------------------|----------------|
| 24230      | Houston Ship Channel Light 56 | \$ 13,452.50 | 24575 | Houston Ship Channel Light 90         | \$ 13,452.50   |
| 24235      | Houston Ship Channel Light 57 | \$ 13,452.50 | 24580 | Houston Ship Channel Light 90A        | \$ 13,452.50   |
| 24240      | Houston Ship Channel Light 58 | \$ 13,452.50 | 24595 | Houston Ship Channel Light 91         | \$ 13,452.50   |
| 24245      | Houston Ship Channel Light 59 | \$ 13,452.50 | 24600 | Houston Ship Channel Light 92         | \$ 13,452.50   |
| 24250      | Houston Ship Channel Light 60 | \$ 13,452.50 | 24750 | Barbours Cut Junction Light BC        | \$ 13,452.50   |
| 24255      | Houston Ship Channel Light 61 | \$ 13,452.50 | 25780 | Houston Ship Channel Light 144        | \$ 13,452.50   |
| 24260      | Houston Ship Channel Light 62 | \$ 13,452.50 | 25785 | Houston Ship Channel Lighted Buoy 145 | \$ 13,452.50   |
| 24295      | Houston Ship Channel Light 63 | \$ 13,452.50 | 25790 | Houston Ship Channel Light 146        | \$ 13,452.50   |
| 24300      | Houston Ship Channel Light 64 | \$ 13,452.50 | 25810 | Houston Ship Channel Light 152        | \$ 13,452.50   |
| Total Cost |                               |              |       |                                       | \$1,327,224.50 |

### 10.3 50-Year O&M Costs

#### 10.3.1 General

The study has to evaluate 50 years' worth of O&M costs resulting from the project. These are the costs to maintain the channel depth with maintenance dredging, as well as maintain the operational capabilities of the placement areas. As different construction options have been developed, numerous O&M options can exist, dependent on what gets built, when its used, and from where is it being used. In general, the methodology used assumed to follow the USACE Future Without Project (FWOP) usage and sequencing of existing placement areas, with new placement being used as various options would construct.

#### 10.3.2 O&M Materials to be Dredged

Maintenance materials dredged during O&M dredging events were assumed to consist of Very Soft Silts & Clays, with a negligible content of loose sands and having an average in-situ density of approximately 95 pcf. For ultimate DMMP planning purposes, all reaches within the study location must be evaluated in terms of their existing shoaling and proposed increased shoaling. Increased O&M shoaling quantities due to proposed measures are dictated by the improvements constructed. For the HSC Bolivar Roads to BCC, quantities vary by the amount of increased footprint.

The O&M material quantities used for the estimates are provided below. These include shoaling rates as provided in the Draft HSC Sedimentation Study (JV, 2012), BSC and BCC Channel

Improvements Project (JV, 2013), and the HSC Preliminary Assessment (USACE, 2017). Increased shoaling rates for enlarged sections were determined by applying the existing shoaling rate in terms of cy/sf, to the increased footprint area. Shoaling increases from deepening only segments were determined by using the Volume of Cut Method, as discussed in Basics of Channel Deposition/Siltation (van Rijn, 2013).

The BSC Flare has recently seen an increase of shoaling beyond the 788,000 CY/Year. This may be due to significant flooding in the Houston/Galveston metroplex. The PDT has determined to utilize the precited shoaling rate and closely monitor the BSC Flare. However, the contingency placed on the dredging quantities and prices was increase from 21% to 30%.

Table 10-9: O&amp;M Material Quantities

| Plan                       | Seg. | Location/<br>Reach                    | Existing<br>Fed.<br>Shoaling<br>Rate<br>(KCY/YR) | Existing<br>Non-Fed.<br>Shoaling<br>Rate<br>(KCY/YR) | Proposed<br>Measure<br>Increased<br>Shoaling<br>Rate<br>(KCY/YR) | Proposed<br>Measure<br>Non-Fed.<br>Inc.<br>Shoaling<br>Rate<br>(KCY/YR) | Avg.<br>Dredge<br>Freq.<br>(YR) | Total<br>O&M<br>Dredge<br>Per Cycle<br>(KCY/Cycle) |         |
|----------------------------|------|---------------------------------------|--|--|--|---|---------------------------------|--|---------|
| NED                        | 1    | HSC – Bolivar<br>to Redfish<br>(S1/2) | 49.6   | -  | 19.0   | -   | 4                               | 274.4  |         |
|                            |      | HSC – Bolivar<br>to Redfish<br>(N1/2) | 49.6   | -  | 24.2   | -   | 4                               | 295.2  |         |
|                            |      | HSC – Redfish<br>to BSC (S1/2)        | 734.5  | -  | 8.4  | -   | 3                               | 2,228.5  |         |
|                            |      | HSC – Redfish<br>to BSC (N1/2)        | 734.5  | -  | 67.2   | -   | 3                               | 2,404.9  |         |
|                            |      | HSC – BSC to<br>BCC (S1/2)            | 385.7  | -  | 25.9   | -   | 3                               | 1,234.7  |         |
|                            |      | HSC – BSC to<br>BCC (N1/2)            | 385.7  | -  | -  | -   | 3                               | 1,157.1  |         |
|                            | 2    | BSC –<br>Channel                      | 498.5  | 24.1   | 84.5   | -   | 2                               | 1,214.2  |         |
|                            |      | BSC – Flare                           | 788.4  | -  | 350.8  | -   | 1                               | 1139.2   |         |
|                            | 3    | BCC –<br>Channel                      | 113.2  | 109.3  | 21.9   | -   | 3                               | 733.0  |         |
|                            |      | BCC – Flare                           | 169.0  | -  | 189.7  | -   | 3                               | 1,076.1  |         |
|                            | 4    | HSC – Boggy<br>to Greens              | 113.7  | -  | 94.3   | 163.2   | 4                               | 1,484.7  |         |
|                            |      | HSC – Greens<br>to Sims               | 215.7  | 1.7  | 13.3   | 51.9  | 5                               | 1,413.2  |         |
|                            | 5    | HSC – Sims to<br>610                  | 38.8   | 9.1  | 4.2  | -   | 6                               | 312.4  |         |
|                            | 6    | HSC – 610 to<br>TB                    | 75.3   | 34.1   | 15.7   | 1.6   | 6                               | 760.3  |         |
|                            |      | HSC – TB                              | 105.1  | -  | 10.9   | -   | 3                               | 348.0  |         |
|                            | LPP  | 1                                     | HSC – Redfish<br>to BSC (S1/2)                   | 734.5  | -  | 276.3   | -                               | 3  | 3,032.4 |
|                            |      |                                       | HSC – Redfish<br>to BSC (N1/2)                   | 734.5  | -  | 276.3   | -                               | 3  | 3,032.4 |
|                            |      |                                       | HSC – BSC to<br>BCC (S1/2)                       | 385.7  | -  | 126.5   | -                               | 3  | 1,536.8 |
| HSC – BSC to<br>BCC (N1/2) |      |                                       | 385.7  | -  | 126.5  | -   | 3                               | 1,536.8  |         |



### 10.3.3 O&M Placement Options

All existing and potential new placement areas were considered for operations and maintenance (O&M) use. These include UCPA sites located in the Bayou segments, UCPA and BU sites in the bay, and USACE concept design for open bay semi-confined BU sites, called BABUS. New UCPA sites considered for maintenance material placement in the bayou include RAE. All PAs evaluated are provided below.

Table 10-10: O&M Placement Options

| Placement Option           | Description   | Est. Cap. (CY) |
|----------------------------|---|----------------|
| Mid Bay                    | Existing UCPA   | 11,406,000     |
| MB Exp. N                  | Potential new UCPA  | 32,300,000     |
| MB Exp. S                  | Potential new UCPA  | 32,300,000     |
| Upland Concept 1           | Potential new UCPA  | 37,552,000     |
| Bird Island Marsh          | Potential new BU site   | 6,300,000      |
| PA 14                      | Existing UCPA   | 9,031,000      |
| PA 15                      | Existing UCPA   | 11,386,000     |
| PA14/15 Connection         | Potential new UCPA connecting existing PA's 14 and 15 <ul style="list-style-type: none"> <li>Initial dike raising to contain fill, 10-foot initial raise assumed</li> <li>Two spillboxes installed</li> </ul> | 10,060,000     |
| Atkinson Marsh Cell M7/8/9 | Unfinished BU site<br>Requires NW to be usable  | 1,735,000      |
| Atkinson Marsh Cell M10    | Existing BU site  | 1,305,000      |
| Atkinson Marsh Cell M11    | Potential new BU site   | 10,267,000     |
| Atkinson Marsh Cell M12    | Potential new BU site   | 6,298,000      |
| Atkinson Marsh Cell M1/M2  | Existing BU site<br>Estimated capacity assumes additional fill required due to 2.28 feet of RSLC  | 1,392,000      |
| Atkinson Marsh Cell M3     | Existing BU site<br>Estimated capacity assumes additional fill required due to 2.28 feet of RSLC  | 1,190,00       |
| Atkinson Marsh Cell NW     | Existing BU site<br>Estimated capacity assumes additional fill required due to 2.28 feet of RSLC  | 1,110,000      |
| Atkinson Marsh Cell M4     | Existing BU site<br>Estimated capacity assumes additional fill required due to 2.28 feet of RSLC  | 1,165,000      |
| Atkinson Marsh Cell M5/M6  | Existing BU site<br>Estimated capacity assumes additional fill required due to 2.28 feet of RSLC  | 2,085,000      |
| Spilman Island             | Existing UCPA   | 14,244,000     |

|                      |   |            |
|----------------------|---|------------|
| Alexander Island     | Existing UCPA   | 17,862,000 |
| Lost Lake            | Existing UCPA   | 6,225,000  |
| Peggy Lake           | Existing UCPA   | 6,296,000  |
| Rosa Allen           | Existing UCPA   | 2,934,000  |
| East Clinton         | Existing UCPA   | 6,290,000  |
| West Clinton         | Existing UCPA   | 5,651,000  |
| House Tract          | Existing UCPA   | 4,560,000  |
| Rosa Allen Expansion | PA created on an existing apprx. 138-acre upland tract of land located west of existing placement area Rosa Allen <ul style="list-style-type: none"> <li>• Initial dike raising to contain fill, 10-foot initial raise assumed</li> <li>• Two spillboxes installed</li> <li>• Includes real estate costs</li> <li>• Assumes site not used for NW placement</li> </ul> | 10,760,000 |
| ODMDS                | Existing offshore material disposal site  | NEL        |

### 10.3.4 O&M Production Variables

#### 10.3.4.1 Pipeline Lengths

Production rates were developed for all study reaches to each placement area. Lines and lengths to each placement area were developed. O&M dredging by hydraulic methods was assumed coverage limited (i.e. limited by walking speed of the dredge rather than pump capability). Clamshell dredging and hopper dredging production rates were determined based predominantly on sail distances as well as equipment operating capacities.

Table 10-11: O&M Dredging Pipeline Lengths

| Reach                                  | Placement Area   | PL Min. (FT) | PL Max. (FT) | PL Avg. (FT) |
|--|--|--------------|--------------|--------------|
| South ½ Lower Bay (108+600 to 138+369) | N/A – (No pipeline dredging assumed for Lower Bay, Hopper dredging only) |              |              |              |
| North ½ Lower Bay (078+844 to 108+600) |  |              |              |              |
| South ½ Mid Bay (53+700 to 78+844)     | Bird Island Marsh  | 19,000       | 44,000       | 31,500       |
|  | MB Expansion South   | 9,000        | 33,500       | 21,000       |
|  | Mid Bay  | 16,500       | 41,000       | 29,000       |
|  | Upland Concept 1   | 20,500       | 45,000       | 33,000       |
|  | MB Expansion North   | 16,500       | 41,000       | 29,000       |
|  | PA 14  | 36,000       | 62,000       | 49,000       |
|  | PA15   | 36,000       | 62,000       | 49,000       |
|  | PA14/15 Connection   | 36,000       | 62,000       | 49,000       |
| North ½ Mid Bay (28+604 to 53+700)     | Bird Island Marsh  | 16,500       | 34,500       | 25,500       |
|  | Mid Bay  | 2,500        | 16,500       | 11,000       |
|  | Upland Concept 1   | 11,500       | 31,000       | 20,000       |
|  | MB Expansion North   | 2,500        | 16,500       | 11,000       |
|  | MB Expansion South   | 2,500        | 21,500       | 11,000       |

|   |  |        |        |        |        |
|---|--|--------|--------|--------|--------|
|   | PA 14                                  | 11,000 | 36,000 | 23,500 |        |
|   | PA15                                   | 11,000 | 36,000 | 23,500 |        |
|   | PA14/15 Connection                     | 11,000 | 36,000 | 23,500 |        |
| South ½ Upper Bay<br>(14+300 to 28+604) | M10                                    | 6,500  | 14,000 | 11,000 |        |
|   | M11                                    | 6,500  | 14,000 | 11,000 |        |
|   | M7/8/9                                 | 6,500  | 14,000 | 11,000 |        |
|   | M5/M6                                  | 22,000 | 24,000 | 23,000 |        |
|   | M1/M2                                  | 20,000 | 37,000 | 28,500 |        |
|   | M3                                     | 14,000 | 32,000 | 23,000 |        |
|   | M4                                     | 14,000 | 32,000 | 23,000 |        |
|   | NW                                     | 14,000 | 32,000 | 23,000 |        |
|   | M12                                    | 15,000 | 29,500 | 22,000 |        |
|   | PA 14                                  | 2,500  | 11,500 | 8,000  |        |
|   | PA 15                                  | 2,500  | 11,500 | 8,000  |        |
|   | Mid Bay                                | 14,000 | 28,000 | 21,000 |        |
|   | Upland Concept 1                       | 13,500 | 27,500 | 20,500 |        |
|   | MB Expansion North                     | 14,000 | 28,500 | 21,000 |        |
|   | Spilman                                | 18,500 | 33,000 | 25,500 |        |
|   | PA14/15 Connection                     | 2,500  | 11,500 | 8,000  |        |
|   | North ½ Upper Bay<br>(-3.94 to 14+300) | M1/M2  | 10,000 | 23,000 | 16,000 |
|   |  | M10    | 13,000 | 27,000 | 20,000 |
| M11                                     |  | 13,000 | 27,000 | 20,000 |        |
| M12                                     |  | 4,500  | 15,000 | 11,500 |        |
| M3                                      |  | 3,500  | 17,500 | 11,500 |        |
| M4                                      |  | 3,500  | 17,500 | 11,500 |        |
| M5/M6                                   |  | 10,000 | 23,000 | 16,000 |        |
| M7/8/9                                  |  | 13,000 | 27,000 | 20,000 |        |
| NW                                      |  | 3,500  | 17,500 | 11,500 |        |
| Spilman                                 |  | 3,500  | 18,500 | 11,500 |        |
| PA 14                                   |  | 9,000  | 24,500 | 17,000 |        |
| PA 15                                   |  | 9,000  | 24,500 | 17,000 |        |
| Mid Bay                                 |  | 28,000 | 42,500 | 35,500 |        |
| Upland Concept 1                        |  | 27,500 | 42,000 | 35,000 |        |
| MB Expansion North                      |  | 28,000 | 42,500 | 35,500 |        |
| PA14/15 Connection                      |  | 9,000  | 24,500 | 17,000 |        |
| BSC – Channel<br>(25+58 to 180+00)      |  | M10    | 14,000 | 29,500 | 22,000 |
|   | M11                                    | 14,000 | 29,500 | 22,000 |        |
|   | M7/8/9                                 | 14,000 | 29,500 | 22,000 |        |
|   | M12                                    | 29,000 | 45,000 | 37,000 |        |
|   | MID BAY                                | 19,000 | 34,500 | 27,000 |        |
|   | M5/M6                                  | 34,500 | 50,000 | 42,000 |        |

|                                   |                                   |        |        |        |
|-----------------------------------|-----------------------------------|--------|--------|--------|
|                                   | PA 14                             | 11,000 | 26,500 | 19,000 |
|                                   | PA 15                             | 11,500 | 27,000 | 19,000 |
|                                   | MB Expansion North                | 18,500 | 34,000 | 26,000 |
|                                   | Upland Concept 1                  | 22,000 | 37,500 | 30,000 |
|                                   | Bird Island Marsh                 | 39,000 | 55,000 | 47,000 |
|                                   | MB Expansion South                | 26,000 | 41,500 | 34,000 |
|                                   | PA14/15 Connection                | 10,000 | 25,500 | 18,000 |
| BSC – Flare<br>(180+00 to 241+00) | M10                               | 12,000 | 16,500 | 14,000 |
|                                   | M11                               | 12,000 | 16,500 | 14,000 |
|                                   | M7/8/9                            | 12,000 | 16,500 | 14,000 |
|                                   | M12                               | 27,000 | 31,500 | 29,500 |
|                                   | M5/M6                             | 32,500 | 37,000 | 34,500 |
|                                   | Bird Island Marsh                 | 33,000 | 40,000 | 36,500 |
|                                   | Mid Bay                           | 17,000 | 23,500 | 20,500 |
|                                   | Upland Concept 1                  | 20,000 | 26,500 | 23,500 |
|                                   | PA 14                             | 9,000  | 13,500 | 11,000 |
|                                   | MB Expansion North                | 16,500 | 23,000 | 19,500 |
|                                   | PA 15                             | 9,500  | 11,500 | 11,500 |
|                                   | MB Expansion South                | 24,000 | 30,500 | 27,000 |
|                                   | PA14/15 Connection                | 8,000  | 12,000 | 10,000 |
|                                   | BCC – Channel<br>(33+00 to 91+98) | M12    | 7,500  | 13,500 |
| NW                                |                                   | 14,500 | 20,500 | 17,500 |
| M1/M2                             |                                   | 19,500 | 25,500 | 22,500 |
| M5/M6                             |                                   | 17,000 | 23,000 | 20,000 |
| M4                                |                                   | 13,000 | 19,000 | 16,000 |
| Spilman                           |                                   | 1,000  | 6,000  | 3,500  |
| M3                                |                                   | 11,000 | 16,500 | 14,000 |
| M10                               |                                   | 30,500 | 36,500 | 33,500 |
| M11                               |                                   | 30,500 | 36,500 | 33,500 |
| M7/8/9                            |                                   | 30,500 | 36,500 | 33,500 |
| Alexander                         |                                   | 22,000 | 26,000 | 24,000 |
| PA 14                             |                                   | 26,500 | 34,000 | 30,000 |
| PA 15                             |                                   | 26,500 | 34,000 | 30,000 |
| PA14/15 Connection                |                                   | 26,500 | 34,000 | 30,000 |
| BCC – Flare<br>(11+00 to 33+00)   | M12                               | 4,500  | 7,500  | 6,000  |
|                                   | M3                                | 8,000  | 11,000 | 9,500  |
|                                   | Spilman                           | 1,000  | 3,000  | 2,000  |
|                                   | M4                                | 10,500 | 13,000 | 12,000 |
|                                   | M5/M6                             | 14,500 | 17,000 | 15,500 |
|                                   | NW                                | 12,000 | 14,500 | 13,500 |
|                                   | M1/M2                             | 17,000 | 19,500 | 18,500 |

|   |                      |         |         |         |
|---|----------------------|---------|---------|---------|
|   | M10                  | 28,000  | 30,500  | 29,000  |
|   | M11                  | 28,000  | 30,500  | 29,000  |
|   | M7/8/9               | 28,000  | 30,500  | 29,000  |
|   | Alexander            | 17,500  | 21,500  | 19,500  |
|   | PA 14                | 24,000  | 28,000  | 26,000  |
|   | PA 15                | 24,000  | 28,000  | 26,000  |
|   | PA14/15 Connection   | 24,000  | 28,000  | 26,000  |
| HSC – Boggy to Greens<br>(684+03 to 833+05)                         | Lost Lake            | 21,500  | 36,500  | 29,000  |
|   | East Clinton         | 22,500  | 37,500  | 30,000  |
|   | E3 Clinton           | 20,000  | 35,000  | 27,500  |
|   | Peggy Lake           | 33,500  | 48,500  | 41,000  |
|   | Rosa Allen Expansion | 30,700  | 45,600  | 38,200  |
|   | Lynchburg            | 64,500  | 79,500  | 72,000  |
| HSC – Greens to Sims<br>(833+05 to 1110+77)                         | Glendale             | 18,000  | 42,500  | 27,500  |
|   | West Clinton         | 15,000  | 33,000  | 24,000  |
|   | East Clinton         | 13,000  | 31,000  | 22,000  |
|   | E3 Clinton           | 10,000  | 28,500  | 19,500  |
|   | House Tract          | 14,500  | 38,500  | 23,500  |
|   | Rosa Allen           | 24,500  | 48,500  | 33,500  |
|   | Lynchburg            | 79,500  | 107,500 | 93,500  |
|   | Rosa Allen Expansion | 23,000  | 47,000  | 32,000  |
| HSC – Sims to 610 &<br>610 to Turning Basin<br>(1110+77 to 1266+48) | Glendale             | 3,000   | 17,000  | 8,000   |
|   | House Tract          | 6,500   | 20,500  | 12,000  |
|   | West Clinton         | 10,000  | 24,000  | 15,000  |
|   | East Clinton         | 15,000  | 29,000  | 20,000  |
|   | E3 Clinton           | 18,000  | 31,500  | 23,000  |
|   | Rosa Allen           | 28,000  | 43,500  | 35,500  |
|   | Lynchburg            | 107,500 | 123,000 | 115,500 |
|   | Rosa Allen Expansion | 26,000  | 42,000  | 34,000  |
| HSC - Turning Basin<br>(00+00 to 30+95)                             | Glendale             | 4,500   | 8,000   | 6,000   |
|   | West Clinton         | 11,500  | 14,500  | 13,000  |
|   | House Tract          | 8,000   | 11,000  | 10,000  |
|   | East Clinton         | 16,500  | 20,000  | 18,000  |
|   | E3 Clinton           | 19,500  | 22,500  | 20,000  |
|   | Rosa Allen           | 43,500  | 46,500  | 45,000  |
|   | Lynchburg            | 123,500 | 127,000 | 125,500 |
|   | Rosa Allen Expansion | 42,000  | 45,000  | 43,500  |

### 10.3.4.2 Haul Distances

O&M hopper dredging estimates were developed by studying historical contract daily production data for multiple projects. Production estimates for O&M dredging were then developed for 8KCY and 10KCY hopper dredges, using the assumed maintenance material density, the various reach distances to the ODMDS, and additional criteria such as two drag-arm digging, overflow allowed, hopper capacity loaded at 75%, and bottom dump out at the ODMDS. Production rates were determined for each dredging reach, for each of the two specified hopper dredge sizes. The developed production rates were inclusive of loading/turning, hauling, and dump, and were assumed over an operational time of 20 hours per day. Distances and cycle times are provided below.

Table 10-12: O&M Production Rates

(Sailing Speed Loaded 12.4-13.2 kts / Sailing Speed Unloaded 14.2-15.1 kts)

| Reach  | Avg. Dist. to ODMDS (NM) | Load Time (HR) | Turning Time (HR) | Travel Time (R/T) (HR) | Dump Time (HR) |
|--|--------------------------|----------------|-------------------|------------------------|----------------|
| South ½ Lower Bay (108+600-138+369)  | 14.2                     | 2.2-2.8        | 0.2               | 2.0-2.1                | 0.1            |
| North ½ Lower Bay (78+844 - 108+600)   | 19.0                     | 2.2-2.8        | 0.2               | 2.7-2.9                | 0.1            |
| South ½ Mid Bay (53+700 - 78+844)  | 23.5                     | 2.2-2.8        | 0.2               | 3.3-3.5                | 0.1            |
| North ½ Mid Bay (28+604 - 53+700)  | 27.7                     | 2.2-2.8        | 0.2               | 3.9-4.2                | 0.1            |
| South ½ Upper Bay (14+300 - 28+604)  | 30.9                     | 2.2-2.8        | 0.2               | 4.4-4.6                | 0.1            |
| North ½ Upper Bay (-3.94 - 14+300)   | 33.3                     | 2.2-2.8        | 0.2               | 4.7-5.0                | 0.1            |
| BSC – Flare  | 30.8                     | 2.2-2.8        | 0.2               | 4.3-4.6                | 0.1            |
| BSC – Channel  | 32.6                     | 2.2-2.8        | 0.2               | 4.6-4.9                | 0.1            |
| BCC – Flare  | 34.8                     | 2.2-2.8        | 0.2               | 4.9-5.2                | 0.1            |
| BCC – Channel  | 35.5                     | 2.2-2.8        | 0.2               | 5.0-5.3                | 0.1            |
| Boggy Bayou to Greens Bayou (684+03 - 833+05)  | 47.1                     | 2.2-2.8        | 0.2               | *7.5                   | 0.1            |
| Greens Bayou to Sims Bayou (833+05 - 1110+77)  | 50.6                     | 2.2-2.8        | 0.2               | *8.6                   | 0.1            |
| Sims Bayou to Turning Basin (1160+62-1266+48)  | 54.1                     | 2.2-2.8        | 0.2               | *9.6                   | 0.1            |
| Turning Basin (1266+48/00+00 – 30+95)  | 55.7                     | 2.2-2.8        | 0.2               | *10.1                  | 0.1            |
| Notes:<br>*Sailing speeds reduced between Morgans Point to Boggy Bayou to 9.9 kts (loaded) and 10.8 kts (empty).<br>Sailing speeds reduced between Boggy Bayou through Main Turning Basin to 6.5 kts (loaded and empty).<br>**Hopper dredging estimates were limited to an 8KCY dredge north of BCC due to size restrictions |                          |                |                   |                        |                |

O&M estimates for clamshell dredging considered mechanically dredging areas with a clamshell dredge and material transport scows. Clamshell production rates were developed assuming a 21 CY bucket over an average cut depth of 48.5 feet below the I-610 Bridge, and 44 feet upstream of



the bridge. Rates were applied over 15 operational hours per day with tugs and 6,000 CY dump scows apportioned accordingly. Haul distances were held by reach as shown for hopper estimates. Travel speeds were set to 4.5 knots when loaded and 6.5 knots when empty. In general, two tugs and three scows were required in estimates from the Boggy Bayou to Greens Bayou reach and downstream. Three tugs and four scows were needed upstream of this reach.

### **10.3.5 O&M Cost Considerations**

Costs were estimated at 2018 price levels and assume standard construction practices. Equipment rates were derived from dredging experience, industry contractors, and several construction and equipment vendors. Labor rates were based on current industry typical standards.

#### **10.3.5.1 Mobilization**

O&M work assumes less equipment and personnel due to minimal shoreside pipe and plant requirements and other atypical work required. Regarding O&M placement area improvements, it is assumed that these mobilizations would be from the surrounding general project area. However, many recent USACE bids for the HSC and tributaries show the costs for mobilization for dike construction and DAMP work also vary greatly. Historical costs were reviewed and averaged and inflated to the study pricing year for this item.

Mobilizations for ancillary tasks were determined on case by case basis and assumed estimated actual equipment/labor costs required for transportation and setup of equipment. These options assumed approximately two weeks for mobilization.

#### **10.3.5.2 Dredging Prices**

The costs for O&M dredging vary significantly from that of NW dredging since additional pipe, equipment and personnel are required for the NW construction versus the O&M work. O&M maintenance assumes less equipment and personnel due to minimal pipe movement and placement methods. Additionally, the material itself is much easier to move. Dredging prices are developed similarly to NW dredging though, in that the production analysis determines the required time and energy requirements. And the operating costs and ownership costs, plus extras are determined; and ultimately dividing by the dredge quantity to get the unit cost.

#### **10.3.5.3 DAMP Costs**

Based on historical experience in disposal area management, it is estimated that 500 LF of perimeter ditch (requiring two passes) or 700 LF of interior ditch (requiring one pass) can be excavated per day, per marsh hoe. Costs per DAMP event were developed using typical industry equipment spreads and production rates. The costs per DAMP event were multiplied by the calculated number of DAMPs that would conceivably be performed per placement location. The

number of DAMPs was determined by dividing the total site capacity by an assumed fill height of four feet based on cut yards per DAMP. This cost was then divided by the total capacity cubic yardage to attain a unit cost of capacity resultant from DAMPing the sites. No DAMP costs were assumed applicable to marsh cells, only UCPA's.

#### **10.3.5.4 Construction General Costs**

O&M dike construction consists of raising the containment dike of a specific placement area. Estimates assume a typical five-foot dike raise with dimensions of common practice. Side slopes were estimated at 3H:1V, extending up from the interior crown edge of the existing dike. Raised dike crown width of 20-feet assumed. Interior slope at 3H:1V down five feet to an interior bench of 30-foot width. Bench sloped down at 3H:1V back to existing interior site grade. Losses for handling and compaction were assumed at 40%. With this and the dike perimeter, material quantities were developed for all placement areas to be considered for future dike raising. Production rates for dike construction assume two draglines side casting materials onto the existing crown from a minimum distance of 50-feet to the interior of the dike; and two dozers shaping the placed materials. Eight hours of operational time were estimated per day. Additional components of dike raising included stripping/clearing/grubbing and turfing.

The cost was determined like that of DAMPing in that the costs per raising event were determined from the developed spread and production rate. Dike raising events were assumed to occur at a frequency of every other DAMP event. Costs include those for stripping/clearing/grubbing pre-construction and turfing post-construction. The cost per raise was then multiplied by the quantity of dike raising events and this cost was then divided by the total capacity cubic yardage to attain a unit cost of capacity resultant from raising the dikes at the sites. No dike raising costs were assumed applicable to marsh cells, only UCPA's.

#### **10.3.5.5 Upfront Dike Raising**

Certain sites would require initial preparations in order to be capable of receiving fill. These include the considered new UCPA's E3 Clinton, Lynchburg Tract, 14/15 Connection, and RAE. For these locations, an initial 10-foot dike raise was assumed. Spread and production was held consistent with other dike raising considerations and was applied to the required material quantity. Costs include those for stripping/clearing/grubbing pre-construction and turfing post-construction.

#### **10.3.5.6 BABUS Cell Construction Costs**

This cost was provided by USACE and was given as \$93,324,000 and \$52,228,000 per 325-ac and 200-ac BABUS, respectively. Cost for capacity was given as \$3.28/CY. For O&M mechanical dredging to a BABUS site, the dredging unit prices developed by USACE Operations were used. The USACE estimates assumed that for each BABUS, 60% of the dredging would be performed via bottom dump scow placement, and 40% would require hydraulic pump out into the cell at an

increased cost. For all dredging costs to BABUS sites, the weighted unit cost was used for dredging, with the storage an added cost per cubic yard. These prices are provided in Table 10-13.

Table 10-13: BABUS Costs

| Reach   | 60%<br>Dump Scow<br>Placement<br>Cost per CY | 40%<br>Hydraulic<br>Placement<br>Cost per<br>CY | Weighted<br>Dredging<br>Unit Cost<br>per CY | BABUS<br>Storage<br>Cost per<br>CY | Total<br>Cost to<br>Dredge<br>and<br>Place in<br>BABUS<br>per CY |
|---|--|---|---|------------------------------------|--|
| Morgans Point to Exxon, Sta 0+00 to Sta 150+00            | \$6.64                                       | \$10.39   | \$8.14                                      | \$3.28                             | \$11.42  |
| Morgans Point to Exxon, Sta 150+00 to Sta 300+00          | \$5.32                                       | \$9.07  | \$6.82                                      | \$3.28                             | \$10.10  |
| Exxon to Carpenters Bayou, Sta 300+00 to Sta 530+00       | \$8.01                                       | \$11.76   | \$9.51                                      | \$3.28                             | \$12.79  |
| Carpenters Bayou to Boggy Bayou, Sta 530+00 to Sta 684.03 | \$11.13                                      | \$14.88   | \$12.63                                     | \$3.28                             | \$15.91  |
| Boggy Bayou to Greens Bayou, Sta 684+03 to Sta 833+06     | \$16.49                                      | \$20.24   | \$17.99                                     | \$3.28                             | \$21.27  |
| Greens Bayou  | \$11.00                                      | \$14.75   | \$12.50                                     | \$3.28                             | \$15.78  |
| Greens Bayou to Sims Bayou, Sta 833+05 to Sta 1110+78     | \$10.89                                      | \$14.64   | \$12.39                                     | \$3.28                             | \$15.67  |
| Sims Bayou to Turning Basin, Sta 1110+78 to Sta 1266+49   | \$17.27                                      | \$21.02   | \$18.77                                     | \$3.28                             | \$22.05  |
| Main and Upper Turning Basins                             | \$17.50                                      | \$21.25   | \$19.06                                     | \$3.28                             | \$22.28  |

## 10.4 LSF Maintenance

O&M costs for LSF were developed using the non-federal shoaling quantities for each standard O&M dredging reach. Non-federal dredging costs were determined in congruence with the channel federal O&M dredging and the same costs were held. I.e., in hydraulic dredging estimates for the channel, non-federal costs were assumed using the same unit prices and to occur during the same mobilization. This was also held for mechanical dredging to BABUS sites. Upon reaching maximum capacity at the Bayou UCPAs, all maintenance dredging goes to the BABUS sites at the unit costs provided by USACE.

At BCC however, when Spilman PA and M12 reach maximum capacity, all material except from the docks would go to ODMDS. The dock materials would be mechanically dredged to a BABUS at the unit price attributed to the Morgan's to Exxon reach as shown above.

*(This page left blank intentionally.)*

# 11 RECOMMENDED PLAN

The project measures include various options for improvements to the HSC, as well as the connected channels BSC and BCC. Channel measures for the NED Plan and LPP (RP) are outlined below in Table 11-1 and placement options for new work and O&M is provided in Table 11-2.

Table 11-1: Recommended Plan Channel Measures

| SE G. | NED PLAN           |                           |   | LPP RECOMMENDED PLAN         |                   |   |
|-------|--------------------|---------------------------|---|------------------------------|-------------------|---|
|       | MEASURE            | STATION                   | DESCRIPTION   | MEASURE                      | STATION           | DESCRIPTION   |
| 1     | CW1_BR-Redfish_700 | 138+369 – 078+844         | Widen HSC between Bolivar to Redfish to 700-foot width. Includes bend easings.  | CW1_BR-Redfish_700           | 138+369 – 078+844 | Widen HSC between Bolivar to Redfish to 700-foot width. Includes 328-foot bend easings. |
|       |                    | 078+844 – 073+934         | Bottleneck transition back to existing 530-foot channel.                        | CW1_Redfish-BSC              | 073+934 – 028+605 | Widen HSC between Redfish to BSC to 700-foot width. Includes 328-foot bend easings.     |
|       | BE1_028+605_530    | 026+028 - 031+171         | 328-foot bend easing along the 530-foot existing channel                        | CW1_BSC-BCC                  | 028+605 – (-)3.94 | Widen HSC between BSC to BCC to 700-foot width. Includes 328-foot bend easings.         |
| 2     | CW2_BSC_455        | 025+58 – 222+76           | Widen BSC on north side to 455-foot width.                                      | CW2_BSC_455                  | 025+58 – 222+76   | Widen BSC on north side to 455-foot width.  |
|       | BE2_BSCFlare       | 203+66 – 239+78           | Widen BSC south side flare radius to 5,375 feet.                                |                              |                   |   |
| 3     | CW3_BCC_455        | 24+69 – 67+11             | Widen BCC on north side to 455-foot width.                                      | NO CHANGE - SAME AS NED PLAN |                   |   |
|       | BETB3_BCCFlare     | 08+78 – 30+84             | Widen BCC flare on north and south to create 1,800-foot diameter turning basin. |                              |                   |   |
| 4     | CD4_Whole          | 684+03 – 974+08           | Deepen HSC between Boggy Bayou and Hunting Turning Bain                         | NO CHANGE - SAME AS NED PLAN |                   |   |
|       | CW4_BB-GB_530      | 684+03 – 833+05           | Widen HSC between Boggy Bayou to Greens Bayou to 530-foot width.                |                              |                   |   |
| 5     | CD5_Whole          | 1110+78 – 1160+62         | Deepen HSC between Sims Bayou to I-610 Bridge.                                  | NO CHANGE - SAME AS NED PLAN |                   |   |
| 6     | CD6_Whole          | 1266+49=00+00 – 30+95     | Deepen HSC between I-610 Bridge and Main Turning Basin.                         |                              |                   |   |
|       | TB6_Brady_900      | 1189+15.688 – 1203+14.265 | 900-foot Turning Basin at Brady Island  |                              |                   |   |

Table 11-2: Placement Options for New Work and O&M

| SEG | NED PLAN   |                             |   | LPP RECOMMENDED PLAN  |                                   |  |
|-----|--|-----------------------------|---|---|-----------------------------------|--|
|     | New Work   |                             | O&M   | New Work  |                                   | O&M  |
|     | To New BU/PAs  | To Existing BU/PAs          |   | To New BU/PAs   | To Existing BU/PAs                |  |
| 1   | 8-Acre Bird Island<br>Long Bird Island<br>Bird Island<br>Marsh | ODMDS                       | ODMDS<br>Bird Island<br>Marsh<br>Mid Bay<br>PA15                  | 8-Acre Bird Island<br>Long Bird Island<br>BSC<br>Sedimentation<br>Attenuation<br>Feature<br>Oyster Pad<br>Mitigation<br>M11 | ODMDS<br>M7/8/9<br>Rehabilitation | ODMDS<br>Bird Island<br>Marsh<br>MidBay<br>PA15<br>M11<br>M7/8/9 |
| 2   | Bird Island<br>Marsh   | N/A                         | PA14<br>P14/15<br>Connectio<br>n<br>ODMDS                         | NO CHANGE - SAME AS NED PLAN  |                                   | PA14<br>P14/15<br>Connectio<br>n<br>ODMDS<br>M7/8/9<br>M11       |
| 3   | M12  | N/A                         | M12<br>Spilman<br>ODMDS<br>BABUS                                  | NO CHANGE - SAME AS NED PLAN  |                                   |  |
| 4   | BW-8 Tract<br>E2 Clinton                                       | N/A                         | Lost Lake<br>BABUS<br>Rosa<br>Allen<br>Rosa<br>Allen<br>Expansion | NO CHANGE - SAME AS NED PLAN  |                                   |  |
| 5   | N/A  | Glendale PA                 | West<br>Clinton<br>BABUS  | NO CHANGE - SAME AS NED PLAN  |                                   |  |
| 6   | N/A  | Glendale PA<br>Filterbed PA | West<br>Clinton<br>House<br>Tract<br>BABUS                        | NO CHANGE - SAME AS NED PLAN  |                                   |  |



## 12 ADDITIONAL STUDIES

---

The following sections outline the additional studies that were conducted post ADM and will be further refined during the PED phase of the project to meet the goals of the accelerated schedule and reduce study costs. Additional studies include, but are not limited to, hydrodynamic modeling, ship simulation, geotechnical investigations and analysis, and review of current AM and AO practices.

### 12.1 Hydrodynamic Modeling

The AdH model was used to produce plots of currents, salinity, sediment concentrations, and shoaling. The currents modeling is described here. Salinity results are summarized in section 7.5 above. Complete modeling results will be in an ERDC Technical Report “Houston Ship Channel 45-Foot Expansion Channel Improvement Project (ECIP) Numerical Modeling Report” by Jennifer McAlpin, Cassandra Ross, and Jared McKnight, ERDC.

The Adaptive Hydraulics (AdH) model is being used to evaluate the potential impacts of proposed channel modifications (TSP) on the hydrodynamics, salinity and sediment behavior in the HSC. The objectives of this effort are to develop a fully calibrated and validated model of Galveston Bay, from the entrance at Bolivar Roads to the turning basin at the Port of Houston. The validated model will be used to establish base conditions against which the proposed project conditions will be evaluated. An analysis of the model results will be conducted to determine the potential impacts of the TSP on important environmental parameters such as salinity, water levels, the tidal prism, sediment transport, and shoaling. A summary of these modeling efforts is summarized below with further details provided in Attachment 4 “Engineering Data and Models.”

A lot of environmental modeling work has been done in Galveston Bay in the past. In the early 1990’s, the Estuarine Engineering Branch (EEB) at the ERDC Coastal and Hydraulics Laboratory (CHL) developed a 3D hydrodynamic and salinity model to evaluate proposed deepening and widening of the HSC in the Bay portion of the channel (Berger et al. 1995a, 1995b). Later work was focused on developing a sediment transport model of the area to investigate the causes of increased shoaling in the ship channel, again focusing on the Bay portion of the channel (Tate et al. 2006, 2008, 2009, and 2012). A Monitoring Completed Navigation Projects (MCNP) Program study was performed on the entrance channel area as well as the Bay portion of the channel to continue the investigation of the suspected increased shoaling (Tate et al. 2014). All the previous EEB modeling in the estuarine area (Bay and HSC) was performed using the TABS-MDS model. The TABS-MDS model is no longer supported by ERDC-CHL.

AdH is a mathematical model developed by ERDC-CHL for the numerical simulation of two-dimensional (2D) and three-dimensional (3D) hydrodynamics, water quality and particle transport. AdH replaces the TABS-MDS model. Demonstrations of the capabilities of the 3D shallow water

module (AdH-SW3) have been carried for the Galveston Bay (Savant et al., 2014; Savant and Berger, 2015).

### **12.1.1 Model Setup**

#### **12.1.1.1 Bathymetry Update**

The bathymetry in the existing Galveston Bay AdH model has been updated using data provided by USACE-SWG. The data sources include channel surveys, navigation charts and aerial imagery covering Galveston Bay, including Trinity Bay and West Bay, from the entrance channel to the upper HSC. This update adds horizontal resolution and additional detail, particularly in the upper portion of the HSC.

#### **12.1.1.2 Other Model Input**

The AdH model requires tidal, salinity and discharge boundary conditions, in addition to sediment loads, bed material composition, and surface wind fields. Field data are also needed for model calibration and validation. These data were obtained from USGS, NOAA, Texas Coastal Ocean Observation Network (TCOON), TCEQ, Texas Water Development Board (TWDB) and other sources. These were additionally augmented with data from USACE field measurements: discharge data were collected in the vicinity of the BSC Flare in 2010; velocity and salinity measurements were collected in the Bay in 2011; sediment data (suspended and bed material) were collected in the Bay in 2005 and 2006. Since there's no continuous record for all the required data sets, calibration and validation were performed over multiple time periods coincident with the available data. The sediment transport portion of the model is being validated using historical dredge records and historical channel surveys.

### **12.1.2 Planned Simulations**

The validated model will be applied to calculate the currents, water levels, salinity, and sedimentation for specified plan conditions. This includes modeling a base condition (BC), one alternative channel condition, one future without project condition, and one future with project condition. The alternatives will be provided by USACE-SWG through consultation with ERDC-CHL.

#### **12.1.2.1 Base Condition**

The BC will be simulated as the present condition. This alternative will match the conditions (geometry and bathymetry) in the final validated model. A single year BC from those generated for the model/field comparisons will be simulated.

### **12.1.2.2 Alternative Channel Condition**

The alternative channel condition specified by USACE-SWG will be incorporated into the model domain mesh as necessary to define the geometric influence on the hydrodynamics and transport conditions. A single year BC from those generated for the model/field comparisons will be simulated with the alternative channel condition to show the impact of the alternative for current conditions.

### **12.1.2.3 Future Without Project (FWOP)**

The FWOP condition will include updated boundary conditions for the proposed future time. Future condition BCs information will be provided by USACE-SWG for river inflow, tidal elevation (including subsidence and sea level rise), salinity input, sediment loads, and wind fields. The model domain will be modified from the BC only to include tidal storage in the event of sea level rise. Additional ADCIRC and STWAVE simulations are required to obtain appropriate BCs for the future condition AdH simulation.

### **12.1.2.4 Future With Project (FWP)**

The FWP condition will include mesh modification to combine the alternative channel condition mesh and the FWOP mesh. The same BCs (provided by USACE-SWG) used in the FWOP simulation will be used for this condition.

The models will be updated in PED to include a study regarding vessel sheer stresses and wakes of larger deeper drafted vessels transiting the channel and potential effects on side slopes, banks, and docks. The models should also be used to evaluate predicted sedimentation and update the shoaling rates.

## **12.2 Ship Simulation**

On November 17, 2017, the USACE Galveston District and the PHA, in consortia with the HP and G&H Towing, concluded ship maneuvering simulations in support of a feasibility study for the HSC-ECIP. The full report is included in Attachment 5, a summary is provided below.

- CW1\_650\_BR-RF, CW1\_650\_RF-BSC, and CW1\_650\_BSC-BCC straight channel sections were simulated and found meetings between two design containerships were considered high-risk, and meetings between the design containerships and tankers were a risky maneuver. Meetings in the 328-foot bends were not simulated as the pilots considered such maneuvers unsafe.
- CW1\_700\_BR-RF, CW1\_700\_RF-BSC, and CW1\_700\_BSC-BCC channel widening measures were simulated and found that meetings between two design containerships and

between design containerships and tankers in both the straight reaches of the channel and in the 328-foot bends were considered acceptable.

- CW2\_455\_BSC: The design 455-foot channel in combination with the 4,000-foot BSC Flare, and 700-foot HSC widening was found to be acceptable. The BSC was simulated with a 400-foot wide channel within the landcut. This was marginally acceptable, however, due to the drift angle required with cross-winds, a 455-foot design for the land cut is preferred.
- TB2\_BSCRORO\_1800 was considered to be acceptable.
- CW3\_455\_BCC inclusive of the BCC Flare widening (BETB3\_BCCFlare\_1800NS) and the 700-foot HSC widening are feasible for the navigation of the design containership, assist tugs and normal HSC vessel traffic.
- CW4\_BB-GB\_530: This measure was found to provide for successful operations of Aframax and Suezmax vessels, which increases the size of ships allowed to operate in this reach above the existing LOA of 750 feet and beam of 106 feet. This allows for the successful implementation of two-way traffic of loaded vessels with a maximum combined ship beam of 246 feet.
- Meetings between a design Arfamax and Panamax was found acceptable both above and below the BW-8 Bridge. Meetings between a design Suezmax and Panamax was found acceptable both above and below the BW-8 Bridge.
- TB6\_Brady\_900: Turning the design Panamax with ships and bunkering barges alongside at Wharfs 26-28 was considered acceptable with sufficient room with the assistance of available tugs.

### **12.3 Advanced Maintenance and Allowable Overdepth**

As noted above, the practices for AM and AO vary throughout the HSC system. The current practices have been used to estimate the current and future dredging needs. However, a more in-depth review of channel shoaling and durations will be conducted to validate or make recommendations to the current AM and AO practices. Additional design level ship simulations to verify dimensions of the channel widening and bend easings will be conducted in PED. In some high shoal areas the AM practice may need to be increased to reduce the frequency of dredging and allow for the PAs to be maintained. In areas of low shoaling the AM and AO practice may be reduced. Currently, the dredging quantities of the BSC Flare and BCC Flare reflect 7 feet of AM. No other changes to AM have been made. AM justification for 7 feet of AM at BSC and BCC is discussed in Section 7.6 of Appendix R.

## **13 SCHEDULE OF DESIGN AND CONSTRUCTION**

---

The Contract Schedule contains the breakout of the contracts with the Dredging Sections pertaining to the new work. Refer to Cost Estimates Summary of Accounts for this information.

*(This page left blank intentionally.)*



## **14 OPERATION AND MAINTENANCE**

---

The plan proposed for maintenance dredging is discussed in the DMMP located in Appendix R.

*(This page left blank intentionally.)*

## **15 ACCESS ROADS**

---

Access roads are not required for channel dredging. Channel deepening will be accomplished by a floating plant. Access to existing and proposed upland placement areas will be from existing public streets. Access to existing and proposed placement sties in the bay would be accessible by water only.

*(This page left blank intentionally.)*

## **16 PROJECT SECURITY**

---

This project consists mainly of channel dredging and levee work. A security plan will not be needed.

*(This page left blank intentionally.)*

## 17 REFERENCES

---

- ASTM International. 2013. *Standard Practice for Environmental Site Assessment: Phase 1 Environmental Site Assessment Process*. (Publication No. E1527-13). West Conshohocken, PA: ASTM International.
- Berger, R. C., R. T. McAdory, W. D. Martin, and J. H. Schmidt. 1995a. Houston-Galveston navigation channels, Texas Project. Report 3, three-dimensional hydrodynamic model verification. Technical Report HL-92-7. Vicksburg, MS: U.S. Army Engineer Waterways Experiment Station.
- Berger, R. C., R. T. McAdory, J. H. Schmidt, W. D. Martin, and L. H. Hauck. 1995b. Houston-Galveston navigation channels, Texas Project. Report 4, three-dimensional numerical modeling of hydrodynamics and salinity. Technical Report HL-92-7. Vicksburg, MS: U.S. Army Engineer Waterways Experiment Station.
- Department of Defense. 2016. *Unified Facilities Criteria (UFC) Design: Moorings*. UFC 4-159-03. Washington, DC: Department of Defense.
- Fugro Consultants, Inc. 2012. Draft Additional Geotechnical Study – Lost Lake DMPA, Houston Galveston Navigation Channel (HGNC), Recovery IDIQ MATOC – Multiple Site Repairs, Harris and Chambers Counties, Texas. U.S. Army Corps of Engineers, Galveston District, Southwestern Division.
- Houston Audubon. (2017). *Evia Island*. Retrieved from <http://houstonaudubon.org/conservation/evia-island.html>.
- HVJ Inc. 2013. Geotechnical Study, Bayport Ship Channel Widening and Deepening Slope Stability Phase II, Report No. HG1019742
- HVJ Inc. 2013. Geotechnical Study, Phase II – North Channel Slope Stability Barbours Cut Ship Channel Improvements. Report No. HG1010561
- Joint Venture: Turner Collie & Braden Inc. & Gahagan & Bryant Associates, Inc. 2012. Draft Report Houston Ship Channel Sedimentation Study. Houston, Texas.
- Joint Venture: Turner Collie & Braden Inc. and Gahagan & Bryant Associates, Inc. 2013. Environmental Assessment in Support of Department of the Army Permit Application SWG-2011-01183 for Bayport Ship Channel Improvements, Harris and Chambers Counties, Texas. Houston, TX.
- Lambe, T.W., and R.V. Whitman. 1969. *Soil Mechanics*. New York, NY: Wiley.
- McAlpin, J., C. Ross, and J. McKnight. 2019a. Houston Ship Channel and Vicinity Three-Dimensional Adaptive Hydraulics (AdH) Numerical Model Calibration/Validation



- Report. ERDC/CHL TR-19-10. Vicksburg, MS: Coastal and Hydraulics Laboratory U.S. Army Engineer Research and Development Center.
- McAlpin, J., J. McKnight, and C. Ross. 2019b. Houston Ship Channel Expansion Channel Improvement Project (ECIP) Numerical Modeling Report. ERDC/CHL TR-19-12. Vicksburg, MS: Coastal and Hydraulics Laboratory U.S. Army Engineer Research and Development Center.
- Powell, E. N., J. Song, and M. Ellis. 1994. *The status of oyster reefs in Galveston Bay, Texas*. Webster, Texas: Galveston Bay National Estuary Program Publication GBNEP-37.
- Savant, Gaurav, R. Charlie Berger, Tate O. McAlpin, and Corey J. Trahan. 2014. Three-Dimensional Shallow- Water Adaptive Hydraulics (AdH-SW3): Hydrodynamic Verification and Validation. ERDC/CHL TR-14-7. Vicksburg, MS: U.S. Army Engineer Research and Development Center.
- Savant, Gaurav and R. Charlie Berger. 2015. Three-Dimensional Shallow-Water Adaptive Hydraulics (AdH-SW3) Validation: Galveston Bay Hydrodynamic and Salinity Transport. ERDC/CHL TR-15-3. Vicksburg, MS: U.S. Army Engineer Research and Development Center.
- Sparr, T. M., Sprague, C. R., & Hann, R. W. 2010. A Study of the flushing times of the Houston Ship Channel and Galveston Bay. Texas A & M University, Civil Engineering Department, Estuarine Systems Project Technical Report, No. 2.
- Tate, J. N., and R. C. Berger. 2006. Houston-Galveston navigation channels, Texas Project: Navigation channel sedimentation study, phase 1. ERDC/CHL TR-06-8. Vicksburg, MS: U.S. Army Engineer Research and Development Center.
- Tate, J. N., R. C. Berger, and C. G. Ross. 2008. Houston-Galveston navigation channels, Texas Project: Navigation channel sedimentation study, phase 2. ERDC/CHL TR-08-8. Vicksburg, MS: U.S. Army Engineer Research and Development Center.
- Tate, J. N., and C. G. Ross. 2009. Houston-Galveston navigation channels, Texas Project: Navigation channel sedimentation study, phase 2 plan simulations. ERDC/CHL TR-09-6. Vicksburg, MS: U.S. Army Engineer Research and Development Center.
- Tate, J. N., and C. G. Ross. 2012. Bayport Flare hydrodynamic study for ship simulation. ERDC/CHL TR-12-13. Vicksburg, MS: U.S. Army Engineer Research and Development Center.
- Tate, Jennifer, Brittany Gunkel, Julie Rosati, Eric Wood, Alejandro Sanchez, Rob Thomas, Naveen Ganesh, and Thad Pratt. 2014. Monitoring Completed Navigation Projects Program Houston-Galveston Navigation Channel Shoaling Study. ERDC/CHL TR-14-14. Vicksburg, MS: U.S. Army Engineer Research and Development Center.

- U. S. Army Corps of Engineers. 1987. *Confined Disposal of Dredged Material*. EM 1110-2-5027. Washington, DC: Department of the Army.
- U. S. Army Corps of Engineers. 1992. *Hazardous, Toxic and Radioactive Waste (HTRW) Guidance for Civil Works Projects*. ER 1165-2-132. Washington, DC: Department of the Army.
- U.S. Army Corps of Engineers. 1995. *Houston-Galveston Navigation Channels, Texas, Limited Reevaluation Report and Final Supplemental Environmental Impact Statement*. Galveston, TX: Galveston District, Southwestern Division.
- U.S. Army Corps of Engineers. 1996. *Navigation and Dredging Operations and Maintenance Policies*. ER 1130-2-520. Washington, DC: Department of the Army.
- U.S. Army Corps of Engineers. 1997. *Life Cycle Design and Performance*. ER 1110-2-8159. Washington, DC: Department of the Army.
- U.S. Army Corps of Engineers. 2000. *Planning Guidance Notebook*. ER 1105-2-100. Washington, DC: Department of the Army.
- U. S. Army Corps of Engineers. 2006. *Hydraulic Design of Deep-Draft Navigation Projects*. EM 1110-2-1613. Washington, DC: Department of the Army.
- U. S. Army Corps of Engineers. 2013. *Incorporating Sea Level Change in Civil Works Programs*. ER 1100-2-8162. Washington, DC: Department of the Army.
- U. S. Army Corps of Engineers. 2014. *Procedures to Evaluate Sea Level Change: Impacts, Responses, And Adaptation*. ETL 1100-2-1. Washington, DC: Chief, Engineering and Construction Division.
- U. S. Army Corps of Engineers. 2015a. *DRAFT MLT to MLLW Vertical Datum Conversion Engineering Design Report: Galveston Harbor, Texas City Ship Channel, Houston Ship Channel*. Galveston, TX: Galveston District, Southwestern Division.
- U.S. Army Corps of Engineers. 2015b. *Dredging and Dredged Material Management*. EM 1110-2-5025. Washington, DC: Department of the Army.
- U.S. Army Corps of Engineers. 2016a. *Houston Ship Channel, Texas Draft Integrated Dredged Material Management Plan and Environmental Assessment*. Galveston, TX: Galveston District, Southwestern Division.
- U.S. Army Corps of Engineers. 2016b. *Civil Works Cost Engineering*. ER 1110-2-1302. Washington, DC: Department of the Army.
- U.S. Army Corps of Engineers. 2016c. *Civil Works Construction Cost Index System*. EM 1110-2-1304. Washington, DC: Department of the Army.

- U.S. Army Corps of Engineers. 2016d. Houston Ship Channel, Texas Draft Engineering Appendix for the Integrated Dredged Material Management Plan and Environmental Assessment. Galveston, TX: Galveston District, Southwestern Division.
- U.S. Army Corps of Engineers. 2017. Houston Ship Channel Expansion Channel Improvement Project, Harris, Chambers, and Galveston Counties, Texas. Engineering Appendix. Galveston, TX: Galveston District, Southwestern Division.
- U.S. Environmental Protection Agency, U.S. Army Corps of Engineers & Texas Commission on Environmental Quality. 2009. *Public Announcement*. Retrieved from <http://www.swg.usace.army.mil/Portals/26/docs/regulatory/SanJacinto.pdf>.
- U.S. Environmental Protection Agency. 2015. *Superfund Site: Patrick Bayou Deer Park, TX*. Retrieved from <http://www.epa.gov/region6/6sf/pdffiles/patrick-bayou-tx.pdf>.

---

*(This page left blank intentionally.)*

---

## **PLATES**

---

*(This page left blank intentionally.)*

---

**ATTACHMENT 1**  
**COST ESTIMATE (MII V4.2)/TPCS/CSRA**



---

*(This page left blank intentionally.)*

---

**ATTACHMENT 2**  
**HSC PIPELINE RELOCATION EVALUATION**

---

*(This page left blank intentionally.)*

---

**ATTACHMENT 3**

**CLIMATE CHANGE AND  
SEA-LEVEL RISE EFFECTS FOR THE  
HSC ECIP FEASIBILITY STUDY**

---

*(This page left blank intentionally.)*

---

**ATTACHMENT 4a**

**ENGINEERING DATA AND MODELS – HOUSTON SHIP  
CHANNEL AND VICINITY TREE-  
DIMENSIONAL ADAPTIVE HYDRAULICS  
(AdH) NUMERICAL MODEL**

---

*(This page left blank intentionally.)*



---

**ATTACHMENT 4b**

**HOUSTON SHIP CHANNEL EXPANSION CHANNEL  
IMPROVEMENT PROJECT (ECIP) NUMERICAL  
MODELING REPORT**

---

*(This page left blank intentionally.)*

---

**ATTACHMENT 5**

**SHIP MANEUVERING SIMULATION STUDY OF  
PROPOSED CHANNEL MODIFICATIONS; HSC-ECIP  
FEASIBILITY STUDY, TEXAS**

***(AVAILABLE UPON REQUEST TO THE GALVESTON DISTRICT  
PROJECT MANAGEMENT)***

---

*(This page left blank intentionally.)*

---

**ATTACHMENT 6**  
**SLOPE STABILITY ANALYSIS FOR BSC AND BCC**  
***(AVAILABLE UPON REQUEST TO THE GALVESTON DISTRICT  
PROJECT MANAGEMENT)***

---

*(This page left blank intentionally.)*

---

**ATTACHMENT 7**

**SLOPE STABILITY ANALYSIS OF  
EXISTING PLACEMENT AREAS**

***(AVAILABLE UPON REQUEST TO THE GALVESTON DISTRICT  
PROJECT MANAGEMENT)***



---

*(This page left blank intentionally.)*

---

**ATTACHMENT 8**  
**CORPS SHOALING ANALYSIS TOOL (CSAT) REPORT**

---

*(This page left blank intentionally.)*

---

**ATTACHMENT 9**

**SEDIMENT TRAINING OPTIONS FOR THE BAYPORT FLARE  
IN THE HOUSTON SHIP CHANNEL**

---

*(This page left blank intentionally.)*

---

**ATTACHMENT 10**  
**CHANNEL MEASURE VOLUME REPORTS**

---

*(This page left blank intentionally.)*